



SEAGATE

Exos AP 4U100 Hardware Installation and Maintenance Guide

Abstract

This document describes initial hardware setup for Seagate Exos AP 4U100 enclosures. It also describes removal and installation of customer-replaceable units for these enclosures. The document is intended for use by storage system administrators familiar with servers and computer networks, network administration, storage system administration and configurations, storage area network management, and relevant protocols.

Firmware Version: Latest available firmware build

P/N 83-00007252-11-01
Revision A
April 2021

© 2019-2021 Seagate Cloud Systems, Inc. All rights reserved. Seagate, Seagate Technology and the Spiral logo are registered trademarks of Seagate Technology LLC in the United States and/or other countries. All other trademarks or registered trademarks are the property of their respective owners. When referring to drive capacity, one gigabyte, or GB, equals one billion bytes and one terabyte, or TB, equals one trillion bytes. Your computer's operating system may use a different standard of measurement and report a lower capacity. In addition, some of the listed capacity is used for formatting and other functions, and thus will not be available for data storage. Actual data rates may vary depending on operating environment and other factors. The export or re-export of Seagate hardware or software is regulated by the U.S. Department of Commerce, Bureau of Industry and Security (for more information, visit www.bis.doc.gov), and may be controlled for export, import and use in other countries. All coded instruction and program statements contained herein is, and remains copyrighted works and confidential proprietary information of Seagate Technology LLC or its affiliates. Any use, derivation, dissemination, reproduction, or any attempt to modify, reproduce, distribute, disclose copyrighted material of Seagate Technology LLC, for any reason, in any manner, medium, or form, in whole or in part, if not expressly authorized, is strictly prohibited. Seagate reserves the right to change, without notice, product offerings or specifications.

Contents

Acronyms	11
About this guide	14
Introduction	14
Intended audience	14
Prerequisites	14
Document conventions and symbols	14
1 Safety guidelines	16
Safe handling	16
Operation	16
Restricted access	17
Electrical safety	17
Rack system safety precautions	18
Leveling an enclosure rack	18
2 System overview	19
Enclosure configuration	19
Enclosure variants	20
Enclosure main components	21
Enclosure front panel	22
Enclosure rear panel	23
Enclosure top	27
Enclosure chassis	31
Overview of front panel LEDs	32
System Power ON/Standby LED (green)	32
ID LED (blue)	32
Port State LED (green)	32
Fault LED–Top lid A (amber)	32
Application Fault LED/Logic Fault LED (amber)	33
Fault LED–Rear panel (amber)	33
Fault LED–Top lid left (top lid B) (amber)	33
Overview of rear panel LEDs	33
Power supply unit	33
System fan module	34
System airflow	35
Controller module	36
Overview of top LEDs	38
Drive Carrier module	38
Controller channel fan module	42
Storage personality module	43
HS Expander module	44
Enclosure management	44
GEM Command-line interface (CLI)	44
3 Installation	45
Installation checklist	45
Planning for installation	45

Preparing for installation	46
Preparing the site	46
Unpacking the enclosure	47
Installing the rack mount rail kit	52
Attaching inner rails to the storage enclosure	61
Installing the 4U100 enclosure	63
Mounting the storage enclosure into the rack cabinet	63
Installing the CMA and crossbar	66
Installing drives	69
Routing cables using CMA	69
Cable requirements for expansion enclosures	76
SAS topology	76
Power cord connection	79
Testing enclosure connections	79
Grounding checks	79
4 Operation	80
Before you begin	80
Powering ON/powering OFF	80
5 Troubleshooting and problem solving	81
Overview	81
Initial start-up problems	81
Faulty power cords	81
LEDs	81
PSU LEDs	81
Front panel LEDs	82
Drive module LEDs	82
Temperature sensors	83
Troubleshooting	83
PSU and system fan faults	84
Thermal monitoring and control	84
Thermal alarm	85
Fault isolation methodology	85
Basic steps	85
If the enclosure does not initialize	86
Host I/O	86
Dealing with hardware faults	86
Continuous operation during replacement	87
Firmware updates	87
Customer-replaceable units (CRUs)	87
CRUs addressing 4U100 chassis	87
6 Module removal and replacement	89
Overview	89
ESD precautions	89
Preventing electrostatic discharge	89
Grounding methods to prevent electrostatic discharge	90
Replacing a PSU module	90
Removing a PSU module	91
Installing a PSU module	92

Replacing a system fan module	93
Removing a system fan module	93
Installing a system fan module	94
Replacing a controller channel fan module	95
Removing a controller channel fan module	95
Installing a controller channel fan module	96
Replacing a Storage personality module	97
Removing the SPM air retention cover	97
Removing a Storage personality module	99
Installing Storage personality module	100
Replacing a HS Expander Module	102
Removing a HS Expander module	102
Installing an HS Expander module	103
Replacing a drive module	103
Removing a LFF drive carrier module	104
Installing a LFF drive carrier module	105
Replacing a Controller module	106
Before you begin	106
Verifying component failure	106
Stopping I/O	107
Removing a Controller module	107
Installing an Controller module	111
Verifying component operation	111
A Technical specifications	112
Enclosure dimensions	112
Enclosure weights	112
Environmental requirements	113
Power supply unit specifications	114
B Standards and regulations	115
International standards	115
Potential for radio frequency interference	115
European regulations	115
Safety compliance	115
EMC compliance	116
AC power cords/universal jumper cords	116
Environmental Standards	116
Recycling of Waste Electrical and Electronic Equipment (WEEE)	117
C Enclosure packaging	118
D BIOS POST Codes	122
Introduction	122
List of POST Codes	122
SEC Phase	122
PEI Phase	123
DXE Phase	124
BDS Phase	125
Post BDS Phase	126
SMM Phase	126

ASL Functionality	127
Intel Reference Code POST Code	127
Memory RC POST Code	127
KIT RC POST Code	128
IIO RC POST Code	128
System BOOT POST Code flow sample	129
Cold Boot Flow	129
Warm Boot Flow	131
Index	134

Figures

1	4U100 enclosure system - dimetric front orientation	19
2	4U100 enclosure system - dimetric rear orientation	19
3	4U100 enclosure system - front panel view	22
4	4U100 enclosure system - rear panel components	23
5	4U100 enclosure - rear panel module slot index diagram (viewed from back)	24
6	Controller module (viewed from back, rotated by 90°)	24
7	Power supply unit (PSU) module detail	25
8	System fan module detail (viewed from back)	26
9	SAS Expansion ports at the rear of 4U100 enclosure	26
10	4U100 enclosure - top view with lids	27
11	Rest front half of top lid A on the back half	28
12	Rest back half of top lid A on the front half	28
13	4U100 enclosure - top view without lids	29
14	4U100 enclosure - slot index diagram (top view)	30
15	LEDs: 4U100 enclosure front panel	32
16	LEDs: 3,200W PSU - rear panel	34
17	LEDs: System fan module	35
18	Controller module	36
19	LEDs: Controller module - rear panel	37
20	LEDs: Dual path LFF 3.5" drive carrier modules - to be inserted from top	39
21	LEDs: Dual path SFF 2.5" disk drive carrier modules with adapters -to be inserted from top	40
22	Dual path SFF 2.5" SSD carrier modules -to be inserted from top	41
23	LEDs: Controller channel fan module - to be inserted from top	42
24	Storage personality module LED location	43
25	LEDs: HS Expander module	44
26	Unpacking the 4U100 enclosure using straps	47
27	Lift handles and their slots present on the enclosure	49
28	Aligning front left lift handle to the enclosure slots	50
29	Sliding the front left lift handle upward	50
30	Attached lift handles	51
31	Separated left rail assembly, inner sides facing	53
32	Extending Left inner rail beyond mid rail	54
33	Location of inner rail safety lock	54
34	Location of mid rail release switch lever	55
35	Measurement of rack post-to-post inside-depth distance	56
36	Default location of outer rail adjustment setscrews	56
37	Measurement of rail from rear to front mount bracket	57
38	Sample adjustment adjusted depth distance for rear-mounting bracket screws	57
39	Alignment of CMA B bracket	58
40	Attach the rear of the outer right rail assembly	59
41	Right front post detail of the inserted outer right rail assembly	60
42	Location of cage nuts	60
43	Left and right inner rail edge details	61
44	Left inner rail alignment	62
45	Lock T-pins and align screw holes	62
46	Attachment of the CMA A bracket	63
47	Align inner rails with mid and outer rails, detail	64
48	Leaf spring latch engaged, extension of mid rail to fully forward and locked position	65

49	Release both safety lock latches.....	66
50	Attachment of the CMA C bracket assembly to the CMA A bracket on the chassis	67
51	Insertion of CMA D bracket into CMA B bracket on the outer rail.....	67
52	Proper installation of the CMA assembly.....	68
53	Direction to tighten crossbar thumbscrews	68
54	Cable routing sequence using Standard capacity CMA.....	70
55	Routing PSU cables.....	70
56	SAS cables routing.....	71
57	Routing 10GbE SFP+ cables of the left controller.....	71
58	Routing 10GbE SFP+ cables of the right controller	72
59	Routing SAS cables.....	72
60	Cable routing sequence using High capacity CMA.....	73
61	Power cable routing (enclosure with High capacity CMA brackets).....	73
62	Routing data cables (enclosure with High capacity CMA brackets).....	74
63	Routing top 4 SAS cables	74
64	Routing right controller SAS cables.....	75
65	Routing right controller Ethernet cables	75
66	Connecting 4U100 enclosure to 4U106 enclosures using Daisy Chain configuration.....	77
67	Connecting 4U100 enclosure to 4U106 enclosures using Star Configuration	78
68	Typical AC power cord connection from PDU to PSU	79
69	LEDs: LFF/SFF Drive carrier LEDs	82
70	Removing a PSU (1 of 2)	92
71	Removing a PSU (2 of 2)	92
72	Removing a system fan (1 of 2).....	94
73	Removing a system fan (2 of 2).....	94
74	Removing a controller fan (1 of 2).....	95
75	Removing a controller fan (2 of 2)	96
76	SPM air retention cover.....	97
77	Mylar tabs freed from the metal tabs	98
78	Side-tab removed from the enclosure.....	98
79	Taking out the other end of the air retention cover from the metal tabs.....	99
80	Removing a Storage personality module (1 of 2).....	100
81	Removing a Storage personality module (2 of 2)	100
82	Guiding slots present on the inner and outer side of a Storage personality module.....	101
83	Locking the SPM at its place using swing-arms.....	101
84	Removing a HS Expander (1 of 2).....	102
85	Removing a HS Expander (2 of 2)	103
86	Removing a LFF drive module (1 of 2).....	104
87	Removing a LFF drive module (2 of 2)	104
88	LFF drive carrier module in open position.....	105
89	Installing a LFF drive carrier module.....	105
90	Controller module blank inserted after removing a Controller module	106
91	Removing a Controller module (1 of 2).....	108
92	Removing a Controller module (2 of 2).....	108
93	Removing blank cover screws	109
94	Losing center locking screw.....	110
95	Inserting PCIe card (Ethernet card in this case) into the PCIe riser card.....	110
96	4U100 enclosure packed in 3-piece box with pallet	118
97	4U100 enclosure packed in RSC box with pallet	118
98	Unpacking the enclosure: 3-piece box with packing.....	120
99	Unpacking the enclosure: RSC box with packing.....	121

100 BIOS phase indication mediums..... 122

Tables

1	Acronyms	11
2	Document conventions	14
3	4U100 enclosure description	20
4	Installation checklist	45
5	Storage system configuration	46
6	PSU LED states	81
7	Expansion port LED status	83
8	Alarm conditions	83
9	Exos AP 4U100 product components	87
10	CRU replacement durations	89
11	4U100 enclosure dimensions	112
12	Exos AP 4U100 component weights	112
13	Exos AP 4U100 total weights	112
14	Ambient temperature and humidity	113
15	Power cooling module specifications	114
16	Safety compliance specifications	115
17	EMC compliance specifications	116
18	AC power cord and universal jumper cord specifications	116
19	POST LED Bit values	122
20	Sec Phase POST codes	122
21	PEI phase POST codes	123
22	DXE phase POST codes	124
23	BDS phase POST codes	125
24	Post BDS phase POST codes	126
25	SMM phase POST codes	126
26	ASL Functionality POST codes	127
27	Memory RC POST codes	127
28	KIT RC POST codes	128
29	IIO RC POST code	128
30	Cold Boot flow sample	129
31	Warm Boot flow sample	131

Acronyms

Table 1 Acronyms

	Acronym	Description
	10GbE	10 Gigabit per second Ethernet
A	AC	Alternating Current
	ANSI	American National Standards Institute
	ASIC	Application-Specific Integrated Circuit
	ATA	Advanced Technology Attachment
	ATX	Advanced Technology Extended
B	BIOS	Basic Input/Output System
	BMC	Baseboard Management Controller
C	CLI	Command Line Interface
	CMA	Cable Management Arm
	CNA	Converged Network Adapter
	CPLD	Complex Programmable Logic Device
	CPU	Central Processing Unit
	CRU	Customer Replaceable Unit
D	DDIC	Disk Drive In Carrier
	DHCP	Dynamic Host Configuration Protocol
E	EBOD	Expanded Bunch Of Disks
	EM	Enclosure Management
	EMC	Electromagnetic Compatibility
	EMI	Electromagnetic Immunity
F	FC	Fibre Channel
	FRB	Fault Resilient Boot
	FCoE	Fibre Channel Over Ethernet
	FCoIB	Fibre Channel Over Infiniband
	FDR	Fourteen Data Rate
	FTP	File Transfer Protocol
G	GB	Gigabytes
	Gb	Gigabits
	GbE	Gigabit Ethernet
	Gbps	Gigabits per Second
	GEM	Genesis Enclosure Management (formerly Generic Enclosure Management)
	GFF	GEM File Format
	GPU	Graphics Processing Unit

Table 1 (continued) Acronyms

	Acronym	Description
H	HA	High Availability
	HBA	Host Bus Adapter
	HDD	Hard Disk Drive
	HTTP	Hypertext Transmission Protocol
I	I2C	Inter-Integrated Circuit
	IANA	Internet Assigned Numbers Authority
	ICL	Inter-Controller Link
	I/O	Input/Output
	IOH	Input/Output Hub
	IOL	IPMI over LAN
	IOPs	I/Os Per second
	IP	Internet Protocol
	iSCSI	Internet Small Computer System Interface
J	JBOD	Just a Bunch of Disks
K	KCS	Keyboard Controller Style
	KVM	Keyboard Video Mouse
L	LAN	Local Area Network
	LED	Light Emitting Diode
N	N/A	Not Applicable
O	OEM	Original Equipment Manufacturer
	OS	Operating System
P	PCB	Printed Circuit Board
	PCI	Peripheral Component Interconnect
	PCIe	PCI Express
	PLD	Programmable Logic Device
	POST	Power On Self Test
	PSU	Power Supply Unit
R	RSC	Regular Slotted Container
S	SAS	Serial Attached SCSI
	SATA	Serial ATA
	SCSI	Small Computer System Interface
	SDK	Software Development Kit
	SES	SCSI Enclosure Services
	SEL	System Event Log
	SEP	Storage (or SCSI) Enclosure Processor
	SFF	Small Form Factor
	SFP	Small Form-factor Pluggable
	SGPIO	Serial General Purpose Input/Output
	SOL	Serial Over LAN

Table 1 (continued) Acronyms

	Acronym	Description
	SSD	Solid State Drive
	ssh	Secure Shell
	SSP	Serial SCSI Protocol
V	VGA	Video Graphics Array
	VPD	Vital Product Data

About this guide

Introduction

This guide provides information about initial hardware installation and setup, as well as removal and installation of customer replaceable units (CRUs) for the Seagate Exos AP 4U100 enclosure. The Exos AP 4U100 is a high capacity server enclosure designed for use in Cloud and Enterprise environments. The Exos AP 4U100 measures 4 EAI units of rack height (7") and fits a 1.2 m rack. It conforms to (CFF) Common Form Factor for canister bay support, and it integrates with Seagate controller enclosures for storage management. The integral Cable Management Arm (CMA) assembly allows the enclosure to be withdrawn from the rack for servicing, while remaining connected and powered in this mode.

Intended audience

This guide is intended for system administrators and storage administrators.

Prerequisites

Prerequisites for using this product include knowledge of:

- Server system administration
- Storage system configuration
- Storage area network (SAN) management and server-attached storage
- Serial Attached SCSI (SAS) protocol

Document conventions and symbols

Table 2 Document conventions

Convention	Element
Green text	Cross-reference links
Black, underlined text	Email addresses
Green, underlined text	Website addresses
Bold text	<ul style="list-style-type: none">• Keys that are pressed• Text entered into a GUI element, such as a box• GUI elements that are clicked or selected, such as menu and list items, buttons, and check boxes
<i>Italic text</i>	Text emphasis
Monospace text	<ul style="list-style-type: none">• File and directory names• System output• Code• Commands, their arguments, and argument values
<i>Monospace, italic text</i>	<ul style="list-style-type: none">• Code variables• Command parameters
Monospace, bold text	Emphasis of file and directory names, system output, code, and text entered at the command line

 **WARNING!** Warning messages alert the reader to a specific procedure or practice which, if not followed correctly, could cause personal injury or catastrophic loss of data or equipment.

 **CAUTION:** Indicates that failure to follow directions could result in damage to equipment or data.

 **IMPORTANT:** Provides clarifying information or specific instructions.

NOTE: Provides additional information.

 **TIP:** Provides helpful hints and shortcuts.

1 Safety guidelines

Safe handling

- △ **CAUTION:** Use this equipment in a manner specified by the manufacturer: failure to do this may cancel the protection provided by the equipment.
- For new enclosures, prepare the site for installation per “[Installation checklist](#)” (page 45), and follow safe-handling instructions provided in “[Unpacking the enclosure](#)” (page 47).
 - Permanently unplug the enclosure before you move it or if you think that it has become damaged in any way.
 - A safe lifting height by hand or without a mechanical server lift is 20U (~35”).
 - The Exos AP 4U100 ships with CRUs installed, except drives. The drives should be only be installed after verifying the enclosure is securely mounted into the rack.
 - Do not attempt to install the enclosure into the rack with drives preloaded into drive slots. The enclosure should be installed without drives during rackmount installation. Unload drives (if installed) to an ESD-protected area and label them. Failure to observe this warning could result in a serious injury.
 - After installing the enclosure, and *before* installing the drives, see “[ESD precautions](#)” (page 89).
 - To install drive modules into a rack-mounted enclosure, face the front panel, and pull the enclosure outward on its rails. Remove the top lid(s) to provide access to the drive module slots. See [Figure 10](#) (page 27) for removable lids, and see [Figure 13](#) (page 29) and [Figure 14](#) (page 30) for drive slots and module slot indexing.
 - Belt straps and optional lift handles are not designed to support an enclosure which is fully populated with drives. See “[Unpacking the enclosure](#)” (page 47).
-

- △ **CAUTION:** Use a suitable mechanical lift for hoisting the enclosure for installation into the rack:
- Fully configured Exos AP 4U100 enclosures can weigh up to 145.60 kg (321 lbs).
 - Use either the enclosure lift handles or lift straps to carry the enclosure without drives installed from its packaging box to the mechanical lift.
 - Observe the lifting hazard label affixed to the storage enclosure.
 - Never use a vacuum lift because it can potentially damage the enclosure.
-

Operation

- ⓘ **IMPORTANT:** Operation of the enclosure with any CRU modules missing will disrupt the airflow, and the enclosure will not receive sufficient cooling. It is essential that all CRU slots hold modules before the enclosure system is used.
-
- Observe the module bay caution label affixed to the module being replaced.
 - Replace a defective CRU with a fully operational CRU as soon as possible. Do not remove a defective CRU module unless you have a replacement model of the correct type ready for insertion.
 - Before removal/replacement of a PSU, disconnect the AC power cords from the PSU to be replaced. See “[Replacing a PSU module](#)” (page 90).
 - Observe the hazardous voltage warning label affixed to power supply modules.

Restricted access

ⓘ IMPORTANT: This equipment is intended for use in a Restricted Access Location only.

A restricted access location is where:

- Access can only be gained by service persons or users who have been fully instructed on the reasons for the restrictions applied to the location and on any precautions that must be taken.
- Access is through the use of a tool or lock and key, or other means of security, and is controlled by the authority responsible for the location.

Electrical safety

- The enclosure must only be operated from a power supply input voltage range of 200–240 VAC, 50 Hz - 60 Hz.
 - Provide a suitable power source with electrical overload protection to meet the requirements in the technical specification.
 - The power cord must have a safe electrical earth connection. Check the connection to earth of the enclosure before you switch ON the power supply.
 - The system requires voltages within minimum fluctuation. The customer-supplied facilities' voltage must maintain a voltage with not more than ± 5 percent fluctuation. The customer facilities must also provide suitable surge protection.
-

ⓘ IMPORTANT: The enclosure must be grounded before applying power.

- The plug on the power supply cord is used as the main disconnect device. Ensure that the socket outlets are located near the equipment and are easily accessible.
 - Exos AP 4U100 enclosures are intended to operate with two PSUs and four fans accessed from the rear panel. Two controller channel fan modules accessed from the top of the enclosure provide additional cooling.
 - Observe the power-supply disconnection caution label affixed to PSU modules.
-

⚠ CAUTION: Do not remove covers from the PSU: there is a danger of electric shock inside. Return the PSU to your supplier for repair.

ⓘ IMPORTANT: The RJ-45 socket on a Controller module is for the Ethernet connection only and must not be connected to a telephone network.

- Exos AP 4U100 storage enclosures are suitable for connection to intra-building or non-exposed wiring or cabling only.
- Exos AP 4U100 storage enclosures are suitable for installation in locations where the NEC (National Electrical Code) applies. These enclosures are not suitable for Outside Plant (OSP) installations.

Rack system safety precautions

The following safety requirements must be considered before mounting the enclosure is mounted in a rack.

- Before installing Exos AP 4U100 into the rack, see the **CAUTION** on [page 16](#) and the **WARNING** on [page 63](#)
 - The rack construction must be capable of supporting the total weight of the installed enclosures. The design should incorporate stabilizing features suitable to prevent the rack from tipping or being pushed over during installation or in normal use.
 - When loading a rack with enclosures, fill the rack from the bottom up, and empty the rack from the top down. Heavier enclosures should be located beneath lighter enclosures for optimal stability.
 - Do not try to lift the enclosure by yourself.
-

△ CAUTION:

- To avoid danger of the rack falling over, under no circumstances should more than one enclosure be moved out of the rack at any one time.
 - The system must be operated with low pressure rear exhaust installation. The back pressure created by rack doors and obstacles is not to exceed 5 pascals (0.5 mm water gauge).
 - The rack design should take into consideration the maximum operating ambient temperature for the enclosure, which is 35°C (95°F), derated by 1°C per 300m above 900m as per ASHRAE Class A2.
 - The rack should have a safe electrical distribution system. It must provide over-current protection for the enclosure and must not be overloaded by the total number of enclosures installed in the rack. When addressing these concerns, consideration should be given to the electrical power consumption rating shown on the nameplate.
 - The electrical distribution system must provide a reliable earth connection for each enclosure in the rack.
 - Each power supply line cord will have an earth leakage current of < 1.0mA. The design of the electrical distribution system must take into consideration the total earth leakage current from all the PSUs in all the enclosures. The rack will require labeling with “High Leakage Current. Earth connection essential before connecting supply.”
 - The rack—when configured with the enclosures—must meet the safety requirements of UL2416, UL60950-1, and IEC 60950-1.
-

Leveling an enclosure rack

The rack should be installed on a flat, leveled surface. It should not rest inclined under any circumstances as this could cause uneven stress on the rack structure, and also on the ground. Enclosures placed in such uneven racks resist smooth movement in the racks while pushing them in or pulling them out. This can eventually damage the enclosure rails. For the safe operation, follow the leveling instructions as prescribed by the rack manufacturer in the rack documentation.

△ CAUTION: Do not install any enclosures into a rack until and unless racks are leveled.

2 System overview

Enclosure configuration

The Exos AP 4U100 storage system supports a 4U (rack space) chassis – refer [Figure 1](#) and [Figure 2](#). It holds up to 96 LFF (3.5") HDDs in main bay, and 4 SFF (2.5") HDD or SSD modules in controller channel bay in a vertical orientation (hence, the term: 4U100). Alternatively, drive slots present in main bay can hold a low profile (5/8-inch high) 2.5" form factor drive with an adapter within the large form factor carrier.

Each individual drive is hot swappable on site. Drive modules must be installed during system setup.

The enclosure configurations—including chassis and CRUs—are described on the following pages. See [“Enclosure variants” \(page 20\)](#) for details about various enclosure options.

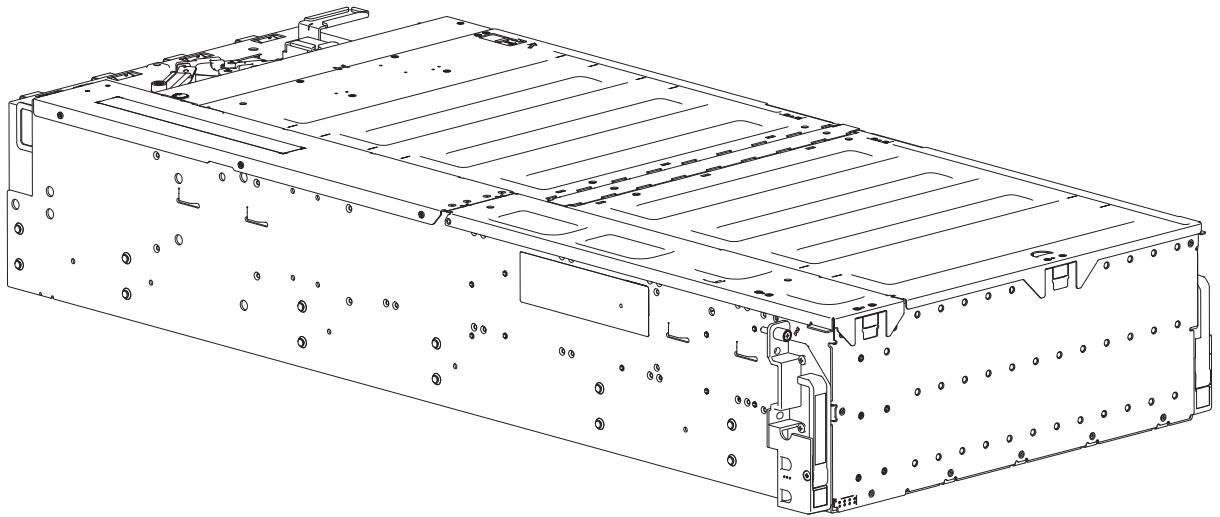

Figure 1 4U100 enclosure system - dimetric front orientation

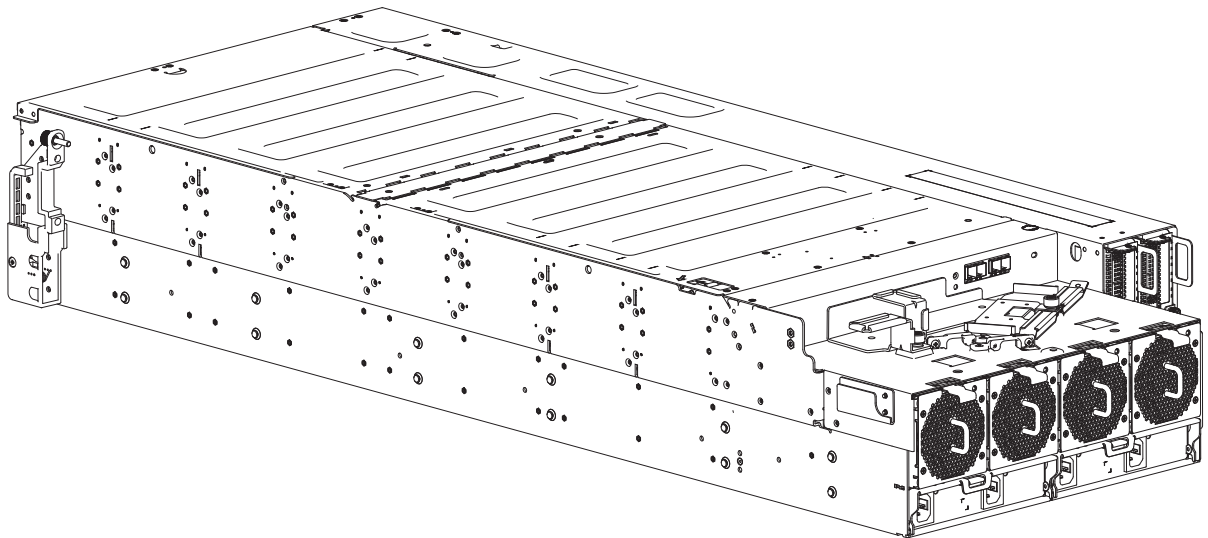

Figure 2 4U100 enclosure system - dimetric rear orientation

Enclosure variants

The 4U100 enclosure is an application platform which can act as a server. There are two types of 4U100 enclosure variants based upon the type of CMA assembly. Throughout the document, the word “CMA” refers to the Cable Management Arm along with its associated brackets. To reduce the complexity, only CMA brackets are shown, and the actual CMA is omitted from the illustrations.

4U100 enclosure variants:

- Enclosure with the standard capacity CMA: This 4U100 variant is equipped with the standard capacity CMA.
- Enclosure with the high capacity CMA: This 4U100 variant is equipped with the high capacity CMA.

Refer to [“Cable management arm \(CMA\)” \(page 27\)](#) for more details about the type of CMA supplied with your enclosure.

NOTE: Enclosure performance is not affected by the type of the CMA used.

Each 4U100 enclosure variant supports:

- 2 Controller modules (a.k.a. Server modules)
- 100 qualified drive modules (96 LFF and 4 SFF) installed via the top panels.
- 8 hot-swappable sideplane expanders which support 96 drives attached to four 24 LFF drive baseplanes (12 drives x 8 rows). If an expander is removed for replacement, the 24 LFF drive baseplane will continue to operate while the high-availability card is replaced.

Table 3 4U100 enclosure description

Product	Description of configuration	PSUs ¹	System fans ²	Controller modules ³	Storage personality modules ⁴	Controller channel fans ²	Drives ⁵	HS expanders ⁶
4U100	12Gb/s direct dock LFF	2	4	2	2	2	100	8
	Enclosure location of CRU variant	Rear	Rear	Rear	Top	Top	Top	Top

1-Redundant PSUs must be compatible modules of the same type (both AC).

2-For adequate cooling, four rear-panel system fans are required, and two fans provide cooling for the controller channel bay (accessed via the top panel).

3-Supported Controller modules act as a server and provide enclosure management services. Supported configurations are either 2 Controller modules or 1 Controller module and 1 blank.

4-Two Storage personality modules connect Controller modules to the drives.

5-It constitutes 96 LFF drives which are supported using the 3.5" carriers; and 4 SFF drives are supported using the 2.5" carriers.

6-Eight Hot-swappable expanders (also known as, Sideplanes) support 24 LFF drive slots per drive bay.

Enclosure main components

The design concept is based on an enclosure subsystem together with a set of plug-in modules. A typical enclosure system—as supplied—includes the following:

- An enclosure chassis equipped with several PCBs, including a midplane, sideplane, and baseplane PCBs, and a cluster of integral enclosure status LED indicators located at the lower left area of the enclosure front panel, near the left ear.
- Two 3200 W 200 V–240 V AC power supply unit modules.
- Fan module (system): four system fan modules for enclosure cooling.
- Two Storage personality modules accessible from the top.
- Two interface slots, each of which holds a Controller module configured with four 10GbE SFP+ ports, one Ethernet management ports (RJ-45), an HDMI port, an USB port (USB 3.0), and a serial port (3.5 mm audio jack).
- Fan module (controller): two controller channel fan modules for controller channel bay cooling.
- Up to 96 LFF drive modules with tool-less LFF wrap-around carrier in the main bay and up to 4 SFF drive modules with tool-less SFF wrap-around carrier in the controller channel bay.
- One removable HS expander per drive row.
- A rail kit for rack mounting.
- A cable management arm (CMA) for managing cables, and enabling in-rack servicing of the enclosure.

NOTE: About enclosure modules

- The drive modules are not installed when the enclosure ships. See [“Populating drive slots” \(page 30\)](#).
- The module quantities quoted above are the maximum that a 4U100 enclosure can support. You can expand the storage capacity by connecting expansion enclosures to 4U100 enclosure.
- Unless otherwise noted within a passage pertaining to a particular CRU, the replacement procedure should be completed within the time period as specified below.
 - PSU: 2 minutes
 - System fan: 2 minutes
 - Drive in LFF carrier in main bay: 2 minutes
 - Controller module: 45 seconds OR
insert the controller service blank (see [Figure 90](#)) within 45 seconds after removal of the controller
 - Drive in SFF carrier in Controller module channel bay: 35 seconds
 - Controller channel fan: 35 seconds
 - Storage personality module: 35 seconds
- Before mounting enclosures into the rack, see the **CAUTION** on [page 16](#) and the **WARNING** on [page 63](#).

Enclosure front panel

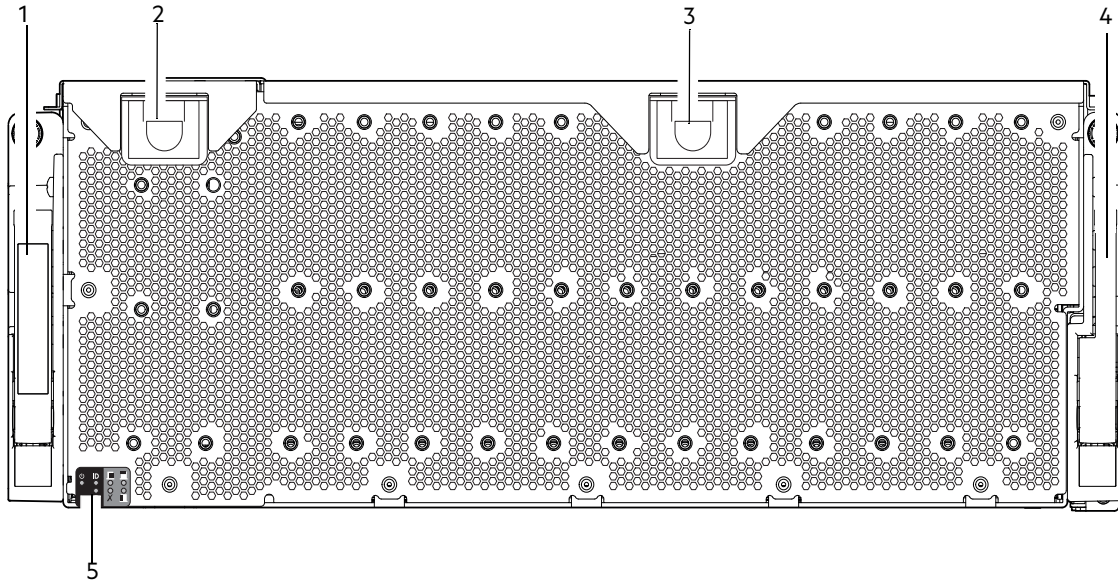

No.	Description	No.	Description
1	Pull-handle (left)	4	Pull-handle (right)
2	Controller channel bay lid latch	5	Enclosure system LEDs
3	Main bay lid latch		

Figure 3 4U100 enclosure system – front panel view

The enclosure front panel displays seven (7) main enclosure system LEDs, which are located in the lower left corner. See [Figure 15 \(page 32\)](#). The front panel also provides access to the left and right enclosure pull handles used to slide the enclosure forward for in-rack servicing tasks.

Enclosure rear panel

This enclosure rear panel view intentionally omits the lift handles that attach to the enclosure sides. For clarity, it also omits the rail kit components that are used when installing the enclosure into the rack.

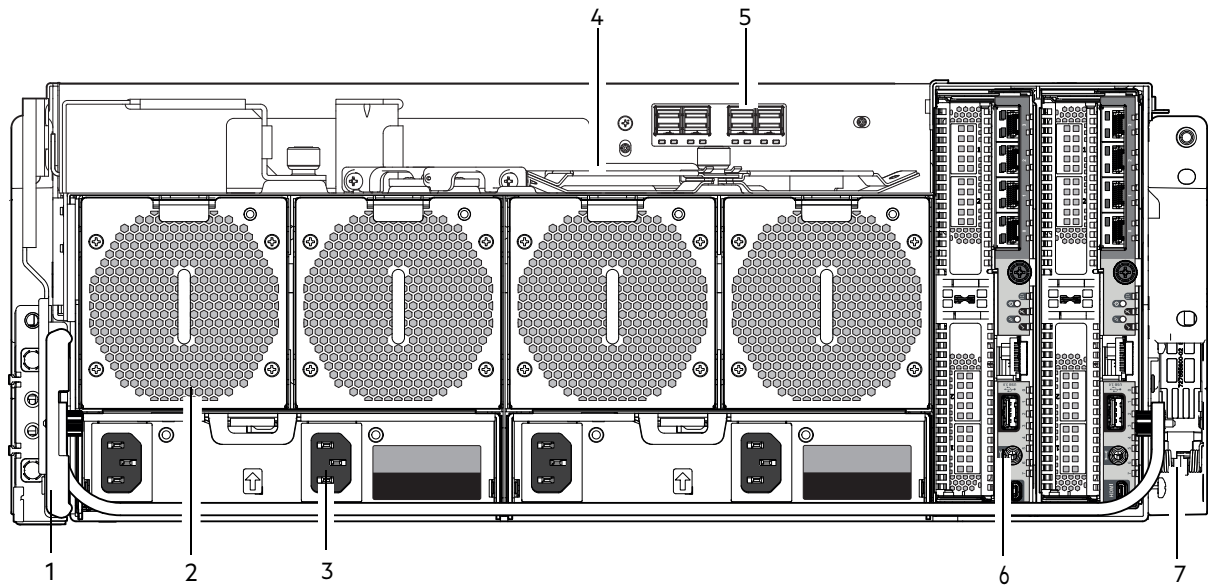

No.	Description	No.	Description
1	Right ear assembly (as viewed from back)	5	MiniSAS HD ports (quantity 4)
2	System fan module (quantity 4)	6	Controller module (quantity 2 or quantity 1 with 1 blank)
3	Power supply unit (quantity 2)	7	Left ear assembly (as viewed from back)
4	Cable shelf and CMA bracket for coiled cables		

Figure 4 4U100 enclosure system – rear panel components

Refer [Figure 5 \(page 24\)](#) for a conceptual diagram showing module slot-indexing as viewed from the rear panel.

Rear panel components

Rear panel components include System Fan modules, PSU modules and Controller modules. (Figure 5) shows how slots for these modules are numbered.

NOTE: Each 4U100 enclosure PSU consists of two cores. Each core provides 1600W power output. Hence, each core is indexed as a separate entity even though they are present in the same PSU (for example, PSU index 0 and PSU index 1 are part of a common PSU - PSU Module 0 which is fitted in PSU slot 0).

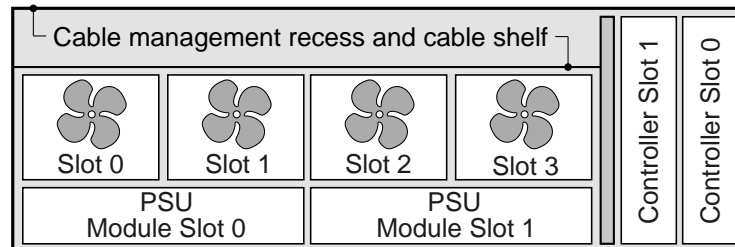
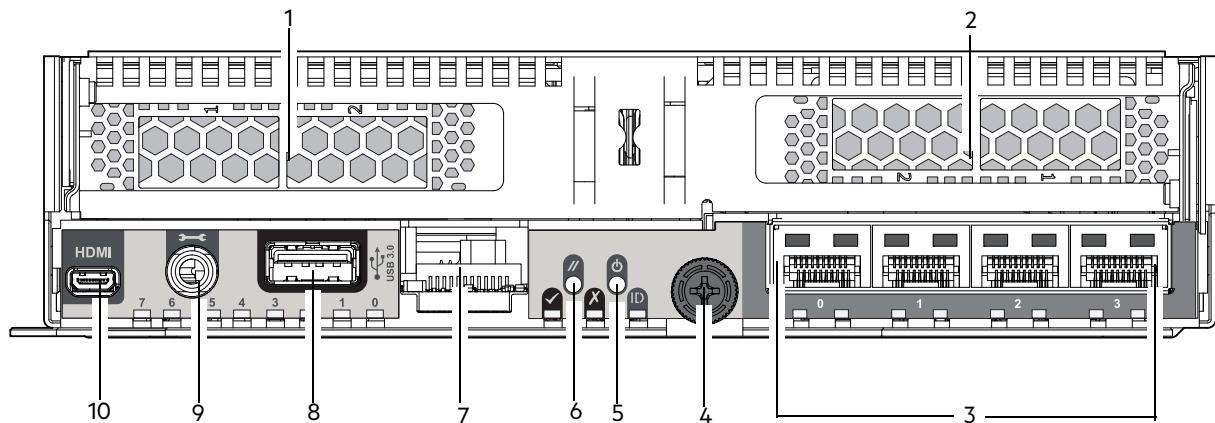

Figure 5 4U100 enclosure – rear panel module slot index diagram (viewed from back)

Controller module

Figure 6 shows the Controller module used in either controller slot located on the enclosure rear panel. The module is shown as it is placed resting on its base. To install the module into one of the slots located on the enclosure rear panel, you would first revolve the module by 90° along its longitudinal axis, as shown in Figure 4 (page 23).



No.	Description	No.	Description
1	PCIe slot no. 0	6	Reset push-button
2	PCIe slot no. 1	7	1Gb Ethernet RJ-45 port
3	10GbE SFP+ port (quantity 4)	8	USB port
4	Retaining thumbscrew	9	Serial port
5	Power push-button	10	microHDMI port

Figure 6 Controller module (viewed from back, rotated by 90°)

NOTE:

Power push-button: Press and release this micro-switch to turn ON the Controller module. To turn OFF Controller module, press and hold this micro-switch.

Reset push-button: Press and release this micro-switch to reset the Controller module.

You need to use a pointed tool for operating the micro-switches.

Power supply unit (PSU)

PSU has following two variants - PSU with BlockPoint (BP) firmware (BP PSU), and PSU without BlockPoint (BP) firmware (non-BP PSU). Your 4U100 enclosure possesses pair of either of these two PSUs. Physically, both PSUs are identical, but their firmware varies remarkably. Hence, it is not recommended to use both PSU variants within the same enclosure.

Figure 7 shows the PSU used in a 4U100 enclosure. The example shows a PSU oriented for use in either PSU slot located on the enclosure rear panel.

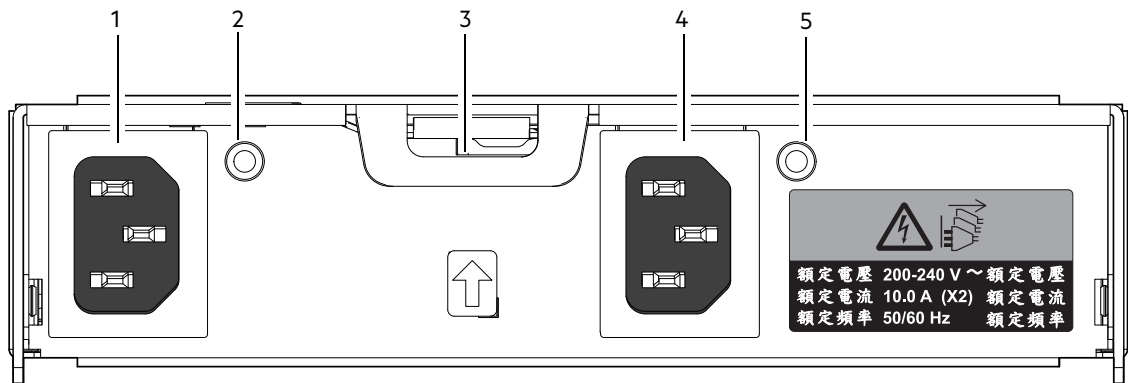

No.	Description	No.	Description
1	AC Power Connect 1	4	AC Power Connect 2
2	PSU Core 1 status LED	5	PSU Core 2 status LED
3	Latch handle		

Figure 7 Power supply unit (PSU) module detail

System fan module

Figure 8 shows a system fan used in a 4U100 enclosure. The example shows a system fan module oriented for use in any of the system fan slots located on the enclosure rear panel.

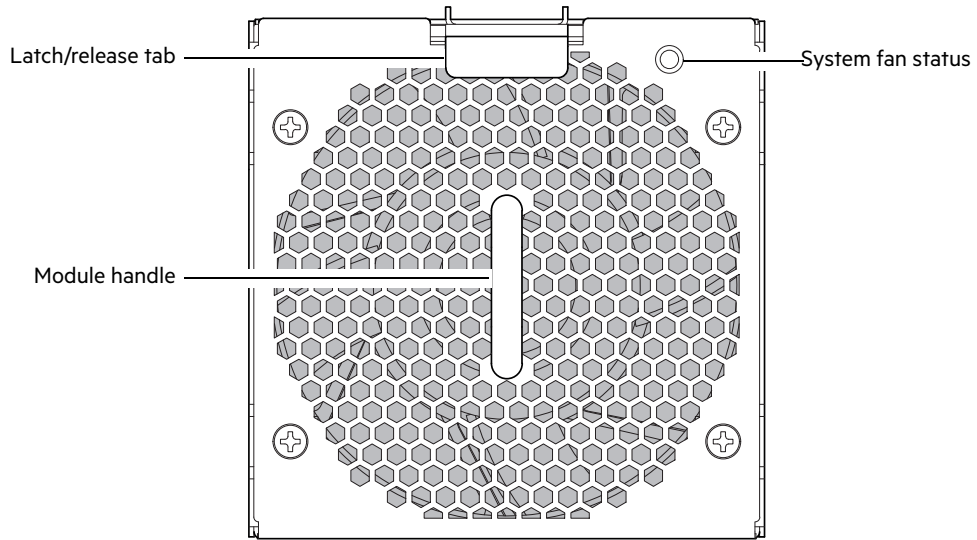
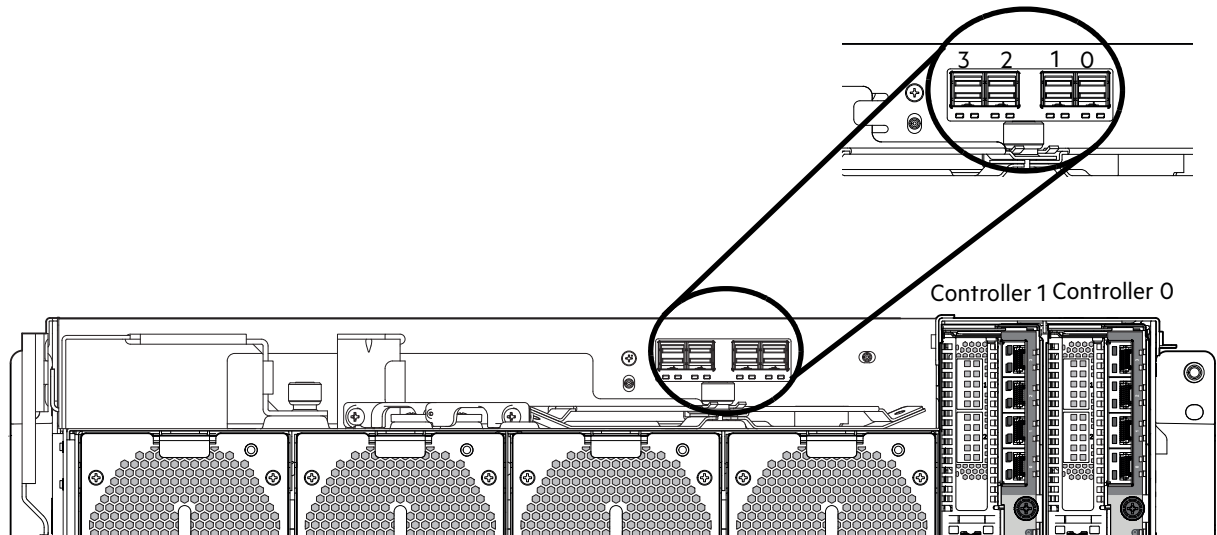

Figure 8 System fan module detail (viewed from back)

Expansion port

SAS expansion ports are present at the back of the enclosure, above CMA. These four expansion ports with the help of mini-SAS cables link the respective 4U100 enclosure to the expansion enclosure.



Expansion ports	Description
0-1	are connected to Controller module 0 (via SPM 0)
2-3	are connected to Controller module 1 (via SPM 1)

Figure 9 SAS Expansion ports at the rear of 4U100 enclosure

Cable management arm (CMA)

The Exos AP 4U100 is supplied with either the standard capacity CMA or the high capacity CMA. The type of CMA supplied is determined at time of sale and is a factory-installed option. Standard and High Capacity CMAs are not interchangeable. This guide covers the use of both types of CMA. The controller modules offer a number of different I/O options (for example, additional PCIe cards) that can require many different types of cabling configurations.

For typical configurations, the standard capacity CMA will suffice. For configurations that require more cables or cable types that have thicker cable diameters, the high capacity CMA will have been selected. Due to specific chassis differences, the standard CMA and high capacity CMA implementations are not interchangeable.

-
- ❗ **IMPORTANT:** The standard capacity CMA fits and operates within the standard 4U rackspace of the Exos AP 4U100. The high capacity CMA requires an extra 1U of rackspace to properly route larger quantity cable configurations. Make sure you take the 5U rackspace requirement into account if the Exos AP 4U100 was delivered with the high capacity CMA.
-

To route the cables through the high capacity CMA, see [“Routing cables using CMA” \(page 69\)](#). Consult your Integration Partner for further details.

Enclosure top

The enclosure top has three different lids, two of which can be removed to provide access to internal components. Within the illustration, the covers are labeled as A/B/C (see call-outs below and [Figure 10](#)).

- **A:** lid A provides access to hot-swap expander cards and LFF disk modules in main bay. Lid A is divided into two parts - front and rear. Both these parts are interconnected through a central hinge. At a time, you can access either front half or rear half of the main bay.
- **B:** lid B provides access to SFF drive modules, Controller bay fans, and Storage personality modules in the controller bay.
- **C:** part of chassis (fixed; non-removable). It provides protection for the Controller modules.

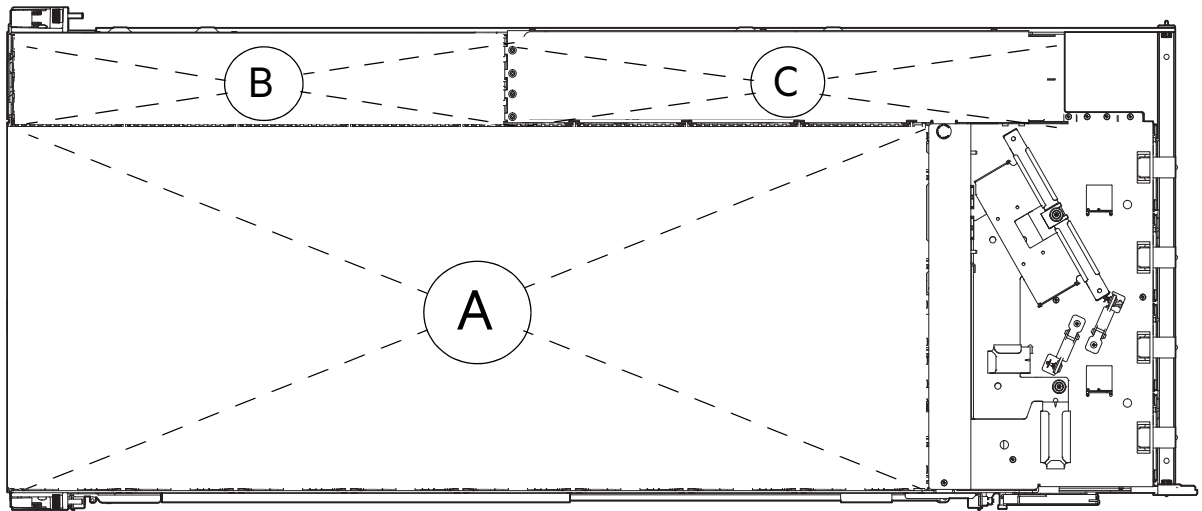

Figure 10 4U100 enclosure – top view with lids

[Figure 10](#) shows a top view of the enclosure with simplified covers. The illustration is oriented such that the front of the enclosure is on left, and the rear of the enclosure is on the right.

The rail kit and most of the cable management arm geometry are omitted for clarity.

Accessing enclosure top lids

Top enclosure top lid A and B (shown in [Figure 10](#)) can be temporarily accessed for a servicing event.

⚠ WARNING! Make sure that there is no obstruction for movement of the lids along its hinge.

Accessing top lid A

While facing the front of the enclosure, depress the exposed front tab of top lid A while gently lifting the rightmost front corner of the lid. Rest the front half of the lid on the closed rear half.

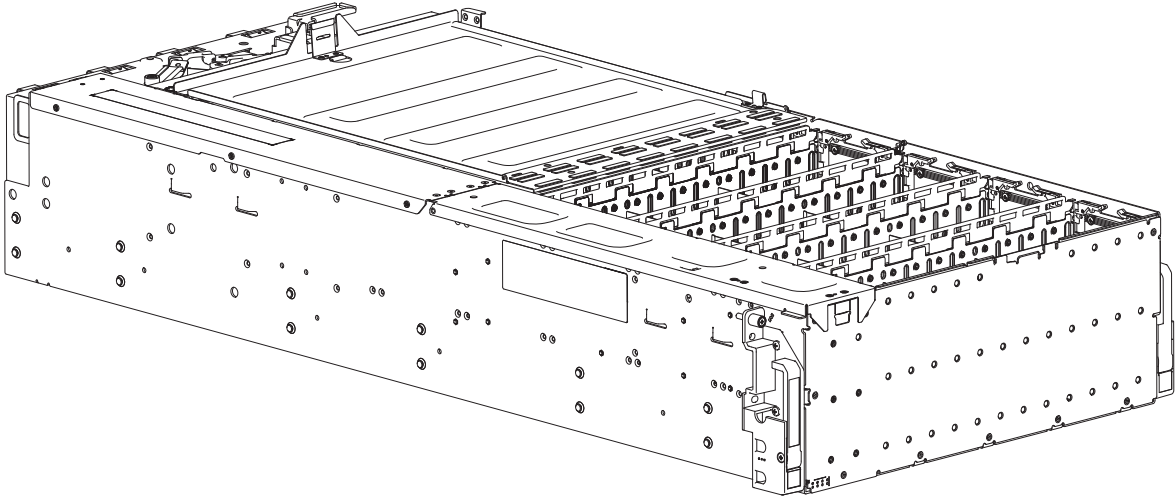

Figure 11 Rest front half of top lid A on the back half

Accessing rear half of the main bay

1. Press downward on the rear main bay latch present on the top lid A and slide it towards the front of the enclosure to unlatch the rear half of the top lid A. Gently lift the rear half and rest it on the closed front half.

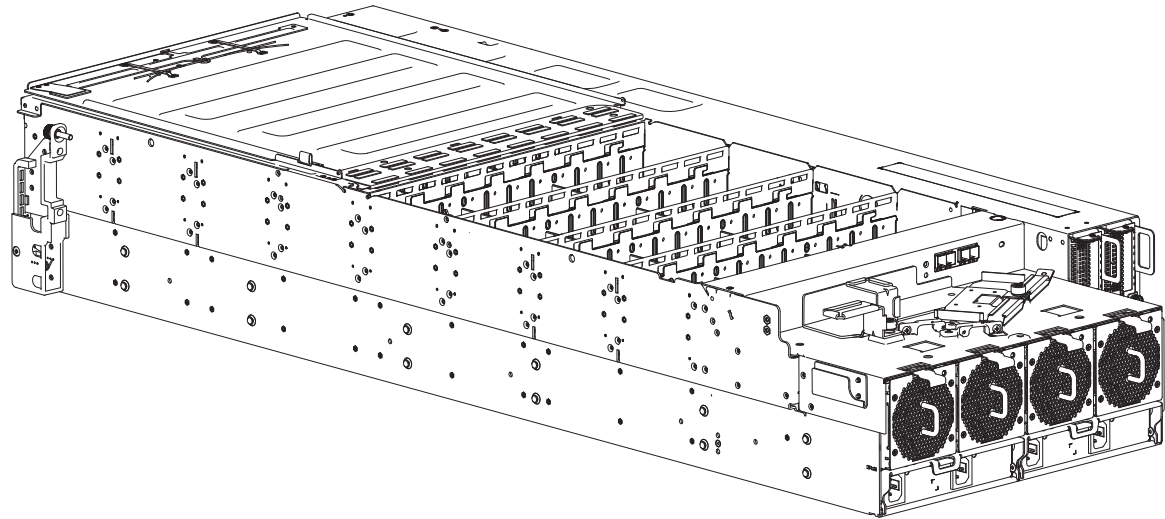

Figure 12 Rest back half of top lid A on the front half

Removing enclosure top lid B

Top lid B is a detachable lid unlike top lid A.

To remove enclosure top lid B, press the latch at the front of top left lid B and pull the lid up. Keep the lid aside.

Figure 13 below shows view of the fully-populated enclosure without lids.

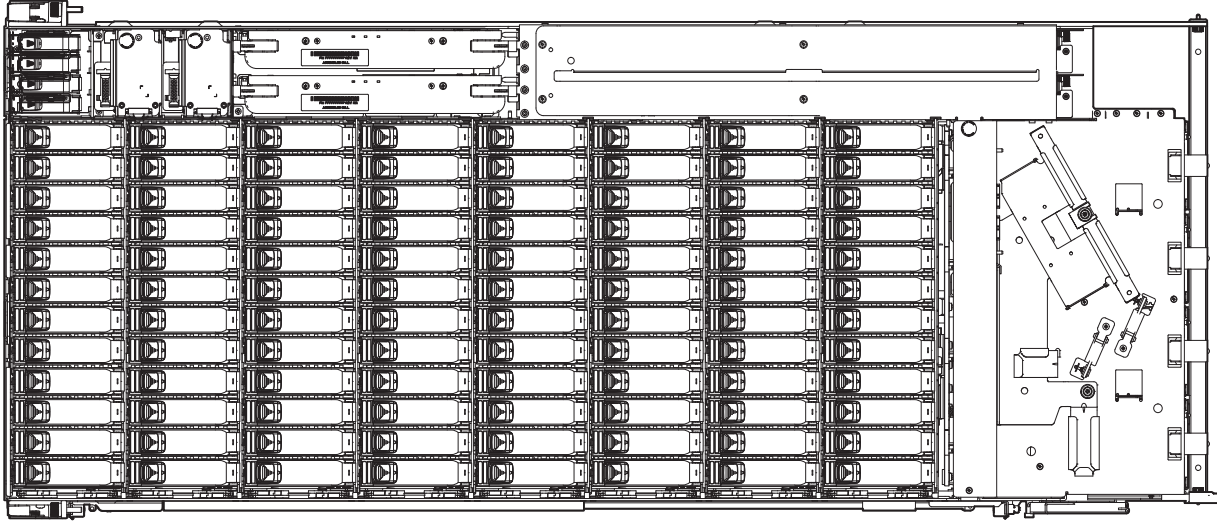

Figure 13 4U100 enclosure – top view without lids

Installing enclosure top lids

Attaching the top lid A

Slowly place the top lid A halves into their original places onto the enclosure while carefully aligning the lid tabs with their appropriate slots. Ensure that the locking tab is positioned between the enclosure and the latch.

1. Gently but firmly press the both halves of lid A down to ensure that the lid tabs lock into place.
2. Close the rear latch of top lid A, present at the front, by rotating it up towards the enclosure and gently press it until it clicks into place.

Installing enclosure top lid B

1. While facing the front of the enclosure, fix the rear side of the lid into its slot.
2. Slowly lower the top lid B down into place onto the enclosure while carefully aligning the front tab with its slot.
3. Gently but firmly press the lid down to ensure that the access panel tab locks into place.

Drive indexing

Figure 14 provides a conceptual diagram of module slot-index numbering as viewed from the top of a 4U100 enclosure with all covers removed. To view the arrangement of PSU module slots—beneath the system fan slots—see Figure 5 (page 24).

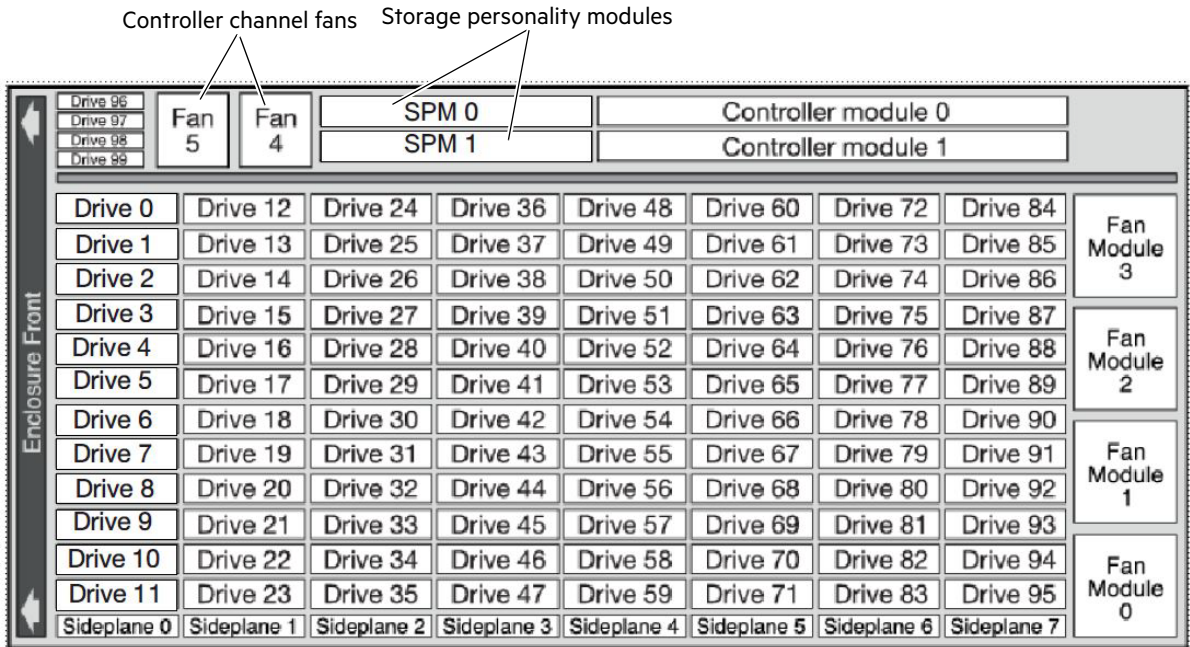

Figure 14 4U100 enclosure – slot index diagram (top view)

The 4U100 enclosure is designed for use with a full load of drives; however, it may also be partially populated. 4U100 enclosure must be populated from front to back.

Populating drive slots

The Exos AP 4U100 does not ship with pre-installed drive modules. When installing drive modules, be mindful of the slot numbering shown in [Figure 14](#). Unless using an alternate arrangement approved by your Seagate EDS technical contact, apply the following rules when populating the main bay of the 4U100 enclosure with LFF modules that consume no more than 12 W per slot.

- Populate the drive slots in the enclosure front to back—filling an entire lateral bay (e.g., drives 0–11)—before populating the next bay (e.g., drives 12–23), and so on.
- When rack-mounting a 4U100 enclosure, install the drives after the enclosure is installed into the rack.

Enclosure chassis

The 4U100 chassis consists of a sheet metal enclosure with integrated PCBs and a module runner system. The enclosure is comprised of a drive channel and a controller channel, and features removable top cover lids. Enclosure top and rear panels provide access to plug-in modules known as customer-replaceable units (CRUs). Each enclosure is comprised of sheet steel that is bonded together using rivets, welding, and other forced contact methods. The metal surfaces are free from non-conductive coatings and paint.

- The 4U100 chassis has a 1.2 m rack mounting that enables it to be installed onto standard 1.2 m racks, and uses
 - 4 units of EIA rack space (i.e. 7") with the standard capacity CMA, and
 - 5 units of EIA rack space (i.e. 8.75") with the high capacity CMA.

Optional lift handles on the chassis side walls facilitate hoisting and installation. See [Figure 30 \(page 51\)](#).

- The Cable Management Arm (CMA) routes cables from the controller channel and external connections, and secures them for in-rack servicing of the installed enclosure.
- An internal high-speed harness ensures routing of cables controlled to specification; protects the interfaces between cables and connectors; and provides a connector system designed for positive (latched) mating.
- The drive channel bus-bar distributes power from the power midplane to 24 LFF drive baseplanes.
- Four baseplane PCBs support 96 LFF drive module connections in the main bay.
- One baseplane PCB supports 4 SFF drive modules in the controller bay.
- The enclosure top lid A provides access to 96 low profile LFF drive modules and HS expanders. Top lid B provides access to 4 SFF drive modules, 2 controller channel fans, and 2 Storage personality modules. All drives are oriented vertically, and held in a Disk Drive In Carrier (DDIC) module (the DDIC is compatible with both rotating and Solid state drives). The DDIC supports the drive and transmits light from the bay LEDs mounted on the baseplane.

NOTE: Enclosure top lids A and B are fixed with a latch mechanism. An operator need to pull out the enclosure on a rail to allow to access one lid at a time for a service event. See [Figure 10 \(page 27\)](#).

- 2 removable, hot-swap expander cards connect through a fixed mount bracket and link card to each of the 24 LFF drive module baseplanes (8 hot-swap expander cards total), providing a dual-path High Availability (HA) connection to the drives plugged into the baseplane.
- Within the controller channel compartment, controller channel fans provide additional cooling for the controller channel bay.
- Within the rear panel, the chassis assembly can hold a maximum of two PSUs, four system fans, two Controller modules, and the flattened cable coils held by the bracket assembly on the CMA shelf (atop system fan sheet metal).

ⓘ **IMPORTANT:** A Controller module service blank must be installed after its removal during servicing. This configuration is required to ensure minimum air loss and sufficient cooling through the enclosure during operation. Each Controller module should be replaced within 45 seconds of its removal, OR the controller service blank should be inserted within 45 seconds to permit servicing of the removed controller without replacing it.

Overview of front panel LEDs

The enclosure front panel displays several LEDs. The front panel displays the functions shown in the illustration below and listed in the table. See [Figure \(page 22\)](#).

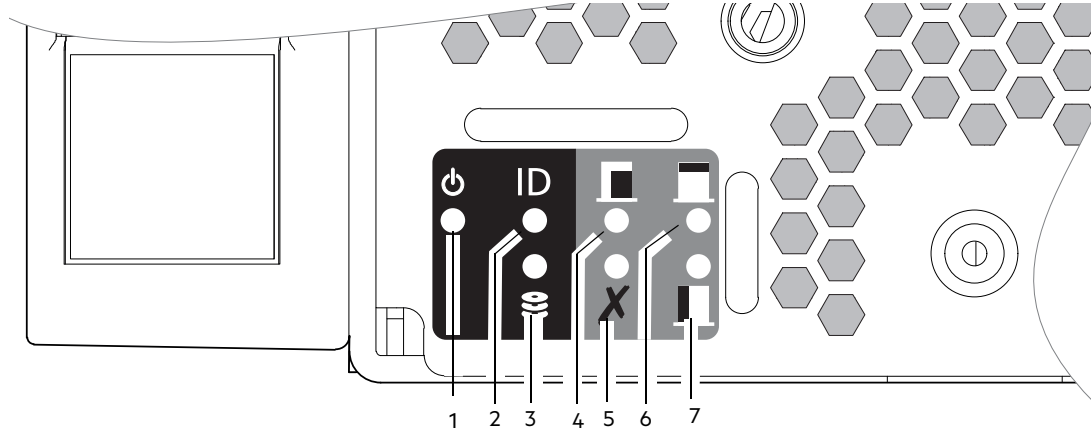

Front panel – lower left corner (partial view)

LED	Front panel functions (lower left corner of panel)	LED	Front panel functions (lower left corner of panel)
1	System Power LED (green)	5	Logic Fault LED (Application Fault LED) (amber)
2	Unit Identifier LED (ID LED) (blue)	6	Module Fault Rear LED (Fault Rear LED) (amber)
3	Port State LED (green)	7	Module Fault Side LED (Fault LED - Top lid left B) (amber)
4	Module Fault LED (Fault LED Top lid A) (amber)		

Figure 15 LEDs: 4U100 enclosure front panel

System Power ON/Standby LED (green)

This LED illuminates Green when system power is available. If the LED is OFF, either the system is powered OFF, or there is a power failure in the system. Troubleshooting to identify the root cause is necessary.

ID LED (blue)

When activated, the ID LED glows blue, and is used to identify the storage system among others installed in the rack. This LED is normally OFF, and illuminates only during the identification process.

Port State LED (green)

This LED will be lit if either of the expansion ports on the enclosure are connected to expansion enclosures and have a valid link.

Fault LED–Top lid A (amber)

The LED illuminates amber when it experiences a system hardware fault with a component accessible via the enclosure top lid A. Amber display indicates that the top lid should be removed to locate the faulty component within the drive channel. This LED is normally OFF, and illuminates only when a fault occurs with a component beneath the top lid. These components include:

- LFF drive modules
- HS expanders

Pull the chassis forward from its installed position within the rack. Remove the top lid and look for an amber LED on any of the drive modules or HS expander modules on the sideplane. Replace the faulty module per the applicable CRU replacement procedure.

Application Fault LED/Logic Fault LED (amber)

The LED is set using SES page. It illuminates amber when request fail bit from “enclosure control element” in SES page 2 is set.

Fault LED–Rear panel (amber)

The LED illuminates amber when experiencing a system hardware fault in a component accessible via the enclosure rear panel. This LED is normally OFF, and illuminates only when a fault occurs with a component installed in the enclosure rear panel.

Observe the enclosure rear panel, and look for a fault indicator on any of the following components:

- Controller modules
- System fan modules
- PSUs

Fault LED–Top lid left (top lid B) (amber)

This LED illuminates amber when experiencing a system hardware fault with a component accessible via the enclosure top. Amber display indicates that the top lid on the left should be removed to locate the faulty component within the controller channel. This LED is normally OFF, and illuminates only when a fault occurs with a component beneath the top lid on the left.

Pull the chassis forward from its installed position within the rack. Remove the top left lid and look for an amber LED on any of the following components.

- SFF drive modules
- Controller channel fans
- Storage personality modules

Replace the faulty module per the applicable CRU replacement procedure.

Overview of rear panel LEDs

This topic gives you a walk-through of the LEDs present on the rear panel components. Power supply units provide optimal power to the enclosure. Cooling is provided by four separate cooling fans and two controller channel fans. The Controller modules along with Storage personality modules provides the ability to manage the enclosure. Also see [“System airflow” \(page 35\)](#) for optimal cooling within the enclosure (s).

Power supply unit

AC-DC power is provided by up to two auto-ranging power supply units (PSUs).

3,200W PSU

Exos AP 4U100 uses two 3,200W PSUs and their operating voltage range is nominally 200 V–240 V AC, with 50 Hz–60 Hz as input frequency. The dimetric rear orientation in [Figure 16](#) shows the PSU aligned for insertion into either PSU slot located on the enclosure rear panel.

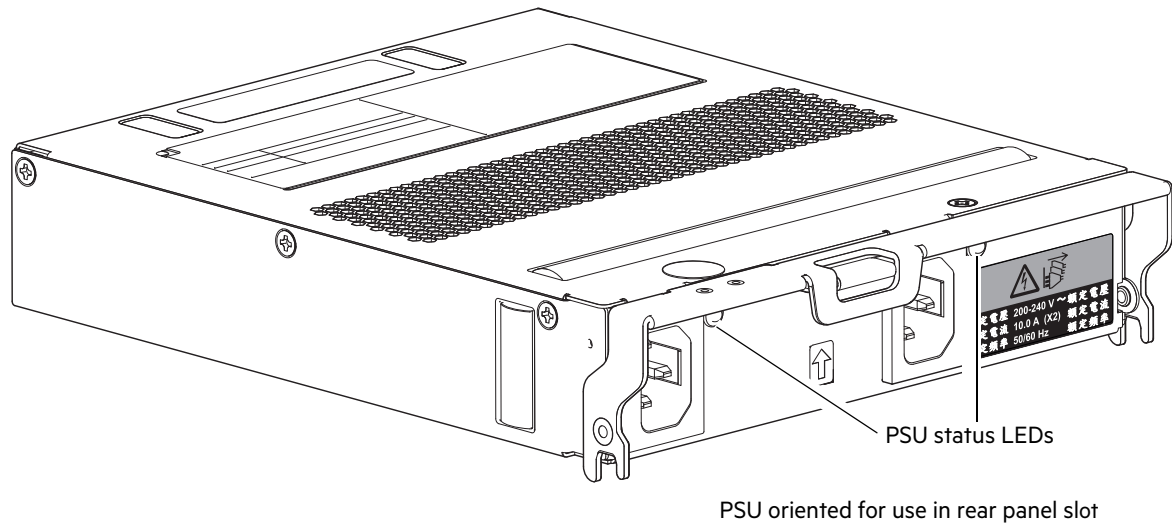

Module LED	LED behavior states				
PSU Status LED (bitonal):	PSU OK (solid green)	Firmware download in progress (blinking green)	PSU fault/low AC supply (solid amber)	Ident bit getting set (blinking amber)	Power OFF (OFF)

Figure 16 LEDs: 3,200W PSU – rear panel

Multiple power supply unit modules

The Exos AP 4U100 storage system includes two PSUs which provide redundant power control for the system so that if one module fails, the other maintains the power supply, and enclosure operation is not affected while you replace the faulty module.

PSUs are hot-swappable, and replacement should only take a few seconds to do. Replacement must be completed as soon as possible after the removal of the defective PSU to avoid a thermal exception. The replacement procedure should be completed within an absolute maximum of 2 minutes.

-
- ⓘ **IMPORTANT:** Operation of the enclosure with any modules missing will disrupt the airflow, and the drives will not receive sufficient cooling. It is essential that the PSU must be installed prior to powering ON the enclosure.
-

System fan module

Figure 17 shows a System fan used in a 4U100 enclosure. System fans are present at the back of the enclosure, above PSUs (see Figure 4). This section provides behavior states of a System fan status LED. Enclosure cooling is provided by the four System fan modules used in combination with the two controller channel fan modules. To know about controller channel fan LED stats, see “Controller channel fan module” (page 42).

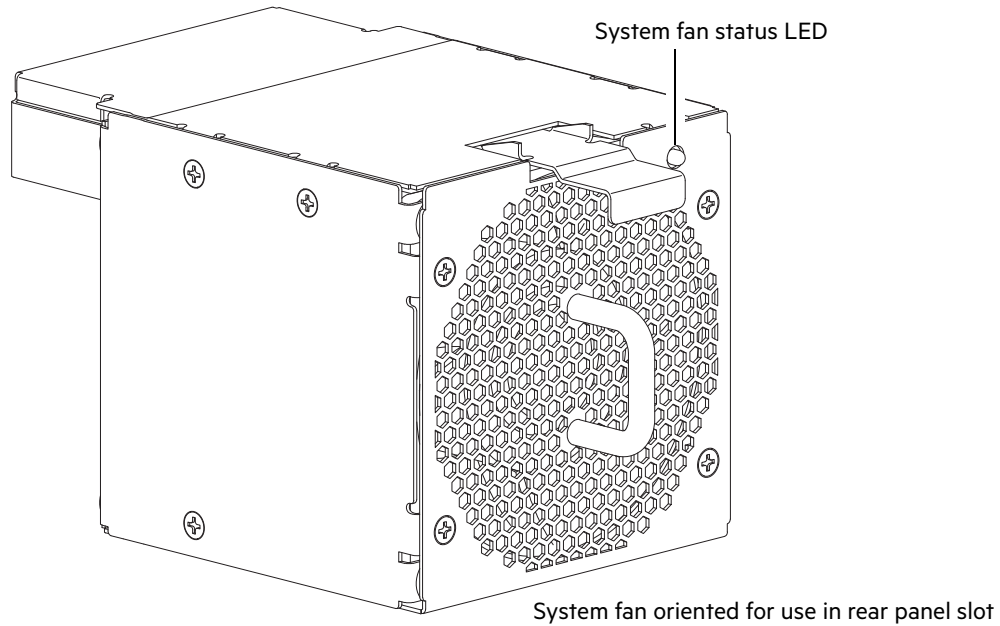

Module LED	LED behavior states		
System Fan Status LED:	System Fan OK (OFF)	Fan fault/ID (amber/blinking amber)	Power OFF (OFF)

Figure 17 LEDs: System fan module

Multiple system fan modules

The 4U100 enclosure includes four rear system fans which provide redundant cooling for the system, so that if one module fails, the others maintain airflow circulation, and enclosure operation is not affected while you replace the faulty module. Within this CRU module, if one of the two internal rotors fails, then a fault occurs, indicating module failure. A dual rotor failure is reported as a dual-fault.

System fans are hot-swappable and replacement should only take a few seconds. Replacement must be completed as soon as possible after the removal of the defective system fan to avoid a thermal exception. The replacement procedure should be completed within an absolute maximum of 2 minutes.

-
- ⓘ **IMPORTANT:** Operation of the enclosure with any modules missing will disrupt the airflow, and the drives will not receive sufficient cooling. It is essential that all slots are fitted with system fans prior to powering ON the enclosure.
-

System airflow

The system must be operated with low pressure rear exhaust installation. Back pressure created by rack doors and obstacles is not to exceed 5 pascals (0.5mm water gauge). The cooling system provides sufficient capacity to ensure that maximum temperatures are not exceeded.

-
- ⓘ **IMPORTANT:** The environment in which the enclosure operates must be dust-free to ensure adequate airflow.
-

Controller module

This section describes the Controller module used in Exos AP 4U100 12Gb/s storage enclosures. It is used as a server module.

The [Figure 18](#) shows a Controller module taken out from the enclosure. You need to insert the Controller module with the same orientation as shown in the figure below.

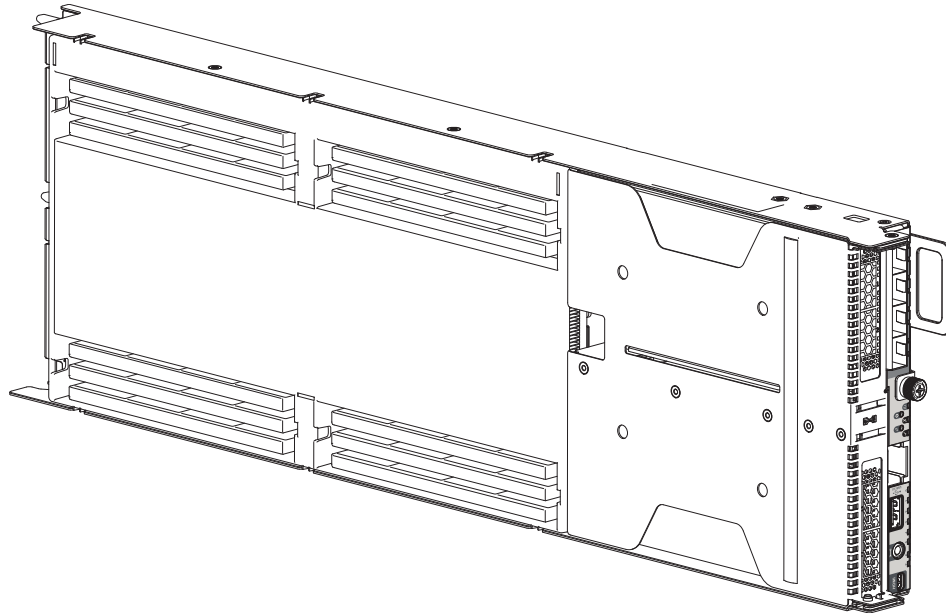
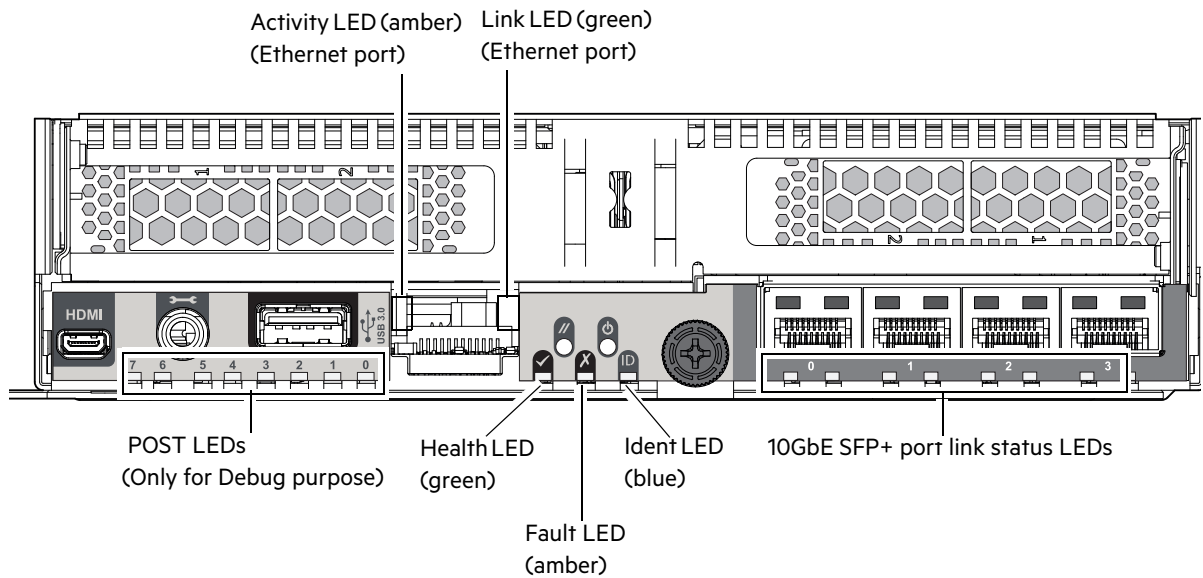

Figure 18 Controller module

The Controller module (a.k.a. Server module) is an Intel server module that is designed for integration into the Seagate Exos AP 4U100 enclosure. The Exos AP 4U100 enclosure is designed to accept two Controller modules providing connectivity to drives.

Each Controller module is a server, with either 1, or 2 Intel x86 CPUs and associated storage, interface, add-in card, and management subsystems. Each Controller module features 2 low profile Peripheral Component Interconnect Express (PCIe) slots that support a variety of qualified PCIe cards including SAS HBAs and high-speed Ethernet adapters. These PCIe slots allow attachment to a host via Fibre Channel (FC), or Fibre Channel over Ethernet (FCoE), or Internal Small Computer Interface (iSCSI), or other methods, as required.

[Figure 19](#) provides a description of the controller module that installs into the rear panel of an Exos AP 4U100 enclosure. The module is shown resting on its base. To install the module into one of the Controller module slots located on the enclosure rear panel, you would first revolve the module by 90° along its longitudinal axis, before inserting it into a slot as shown in [Figure 4 \(page 23\)](#). Showing server modules separately from the enclosure enables improved clarity in identifying the component items called out in the diagrams and described in the companion tables within the figure/table ensembles.



Locations	LEDs		Description
10GbE SFP+ port	Top LED (amber)	ON	Fault in the SFP+ port
		OFF	No fault in the SFP+ port
	Bottom LED (green)	ON	Link is up
		Blinking	Indicates link status to activity on the port
Controller module card	Ident (blue)	ON	SES device Ident function
		OFF	Normal state
	Fault (amber)	ON	Indicates fault in the Controller module
		OFF	No fault in the Controller module
	Health (green)	ON	Indicates AP-RH controller is has power ON (may be standby or powered on states)
		OFF	No power to the Controller module
Ethernet Port	Link LED (green)	ON	Indicates link status (normal operation)
		OFF	Ethernet cable is not connected or no power supplied
	Activity LED (amber)	Blinking	Indicates on-going activity
		ON	Link is up, no activity
	OFF	No activity	

Figure 19 LEDs: Controller module – rear panel

Overview of top LEDs

To view LEDs of components that are accessible from the top, you must first remove the lid of the compartment in which the component is installed. The enclosure top is shown in [Figure 10 \(page 27\)](#).

Drive Carrier module

The drive carrier module comprises a hard disk held by a carrier. Such single unit is called as DDIC (Disk drive-in Carrier).

- Each of the 96 LFF drive module slots in the main bay can hold a single low profile (1.0-inch) 3.5-inch form factor drive in the LFF carrier, or a single 2.5-inch form factor drive with an adapter and the LFF carrier.
- Each of the 4 SFF drive module slots in the controller bay can hold a single low profile (5/8-inch) 2.5-inch form factor drive in the SFF carrier.
- The drive modules are inserted into vertically aligned slots that are accessible from the top of the enclosure. While facing the front of the enclosure, properly orient the drive module for insertion into the slot:
 - Hold the module so that the front is facing you (latch tab on left, and drive PCB facing up).
 - Revolve the module -90° about the horizontal axis (latch is facing up, module is standing on end).
 - Revolve the module 90° about the vertical axis (latch is facing up, drive PCB is facing left).

A plastic carrier supports each drive in the drive slots. The drive in the carrier is known as a DDIC or drive module. The carrier has a latching arm that provides the following functions:

- Secure location of the carrier into and out of drive slots.
- Positive spring-loading of the drive/midplane connector.

The carrier can use this interface:

- Dual path direct dock Serial Attached SCSI.

NOTE: Pictorial views of the supported DDIC with LFF drive are provided below. Modules are shown oriented for insertion into drive slots located on the enclosure top.

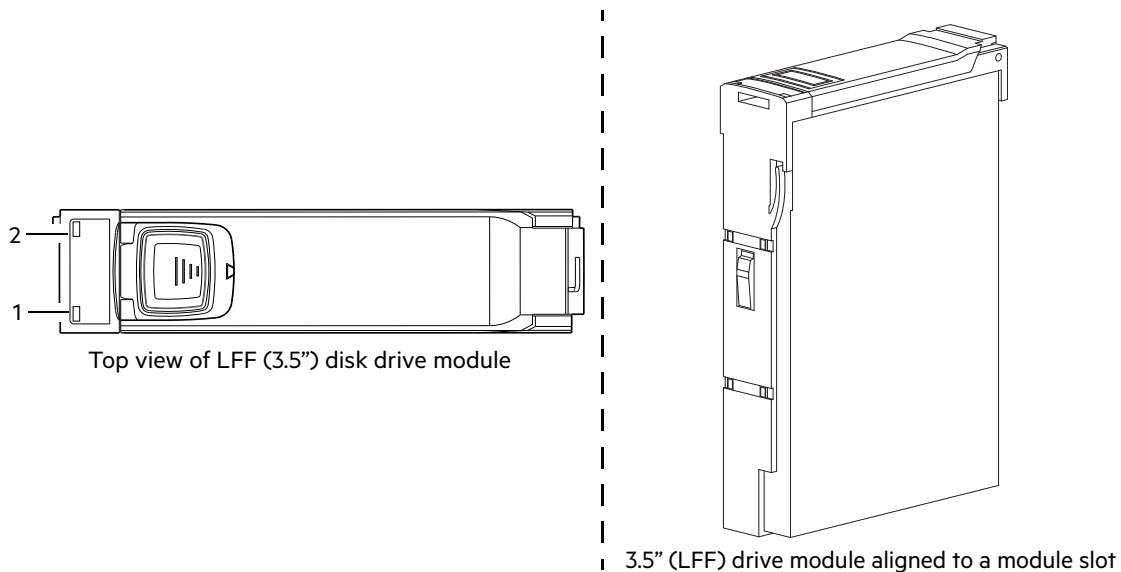

LED	Description	Definition
1	Unused LED	-----
2	Fault/Ident bit	OFF — The disk drive module is operating normally. Solid amber — A fault has been detected or a service action is required. OR Blinking amber (1s ON, 1s OFF) — Ident bit is set.

Figure 20 LEDs: Dual path LFF 3.5" drive carrier modules - to be inserted from top

The replacement procedure of a DDIC should be completed within an absolute maximum of 2 minutes. For additional information about LFF drive LED behavior, see ["Drive module LEDs" \(page 82\)](#).

NOTE: Pictorial views of the supported DDIC with SFF drive and adapter are provided below. Modules are shown oriented for insertion into drive slots located on the enclosure top.

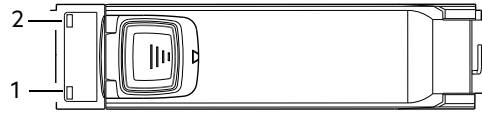

Top view of SFF disk drive module

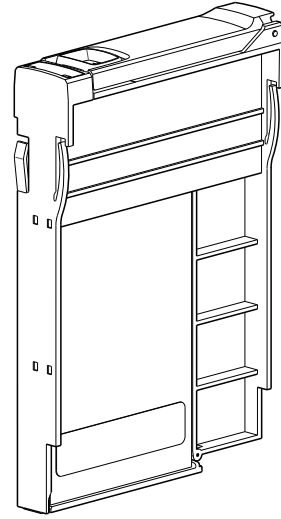

2.5" (SFF) drive in 3.5" adapter aligned to module slot

LED	Description	Definition
1	Unused LED	----
2	Fault/Ident bit	OFF — The disk drive module is operating normally. Solid amber — A fault has been detected or a service action is required. OR Blinking amber (1s ON, 1s OFF) — Ident bit is set.

Figure 21 LEDs: Dual path SFF 2.5" disk drive carrier modules with adapters -to be inserted from top

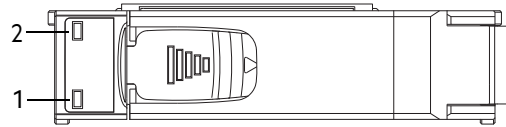

SFF (2.5") SSD top view

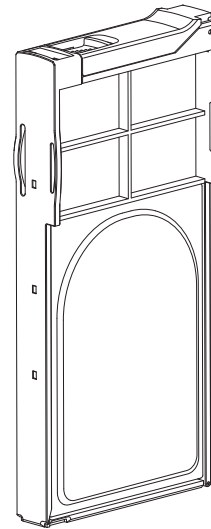

SFF (2.5") SSD aligned to module slot

LED	Description	Definition
1	Unused LED	----
2	Fault/Ident bit	OFF — The disk drive module is operating normally. Solid amber — A fault has been detected or a service action is required. OR Blinking amber (1s ON - 1s OFF) — Ident bit is set.

Figure 22 Dual path SFF 2.5" SSD carrier modules -to be inserted from top

The replacement procedure should be completed within an absolute maximum of 2 minutes. For additional information about SFF disk LED behavior, see [“Drive module LEDs” \(page 82\)](#).

Controller channel fan module

The controller channel fan moves air through the enclosure controller channel, providing cooling for the Storage personality modules, and Controller module or modules. These fans are located between SSDs, and Storage personality modules, and they can be accessed from the top. The replacement procedure for the controller channel fan module should be completed within an absolute maximum of 35 seconds.

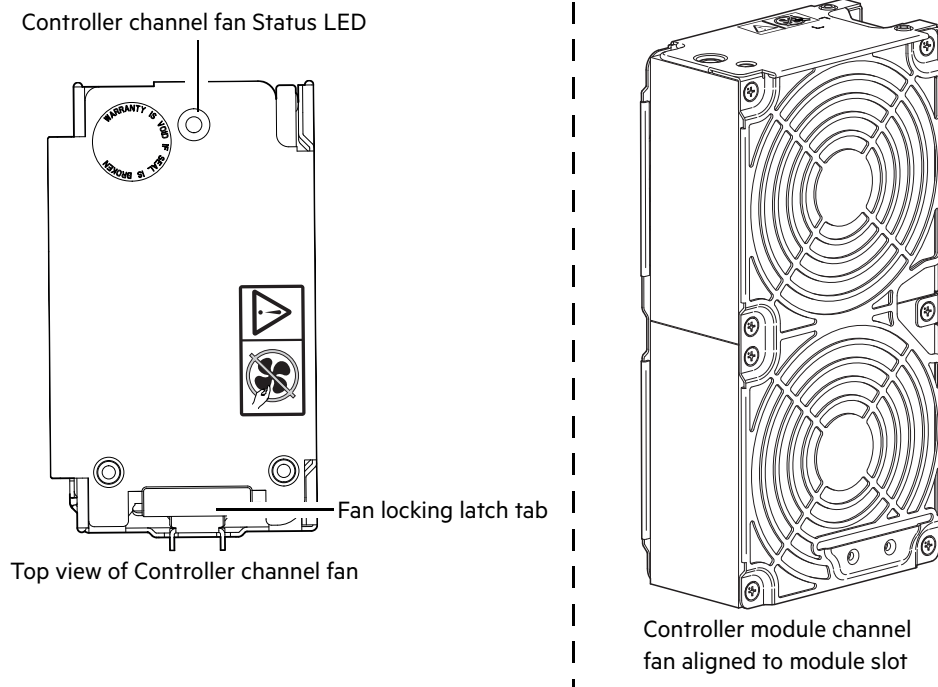

Module LED	LED behavior states		
Fan Status LED:	Controller channel Fan OK (OFF)	Fan fault ID (amber/blinking amber)	Power OFF (OFF)

Figure 23 LEDs: Controller channel fan module – to be inserted from top

Storage personality module

Storage personality module include SAS expanders that provide physical connections to the Sideplanes and SSDs. Storage personality module act as a medium between Controller modules and drives.

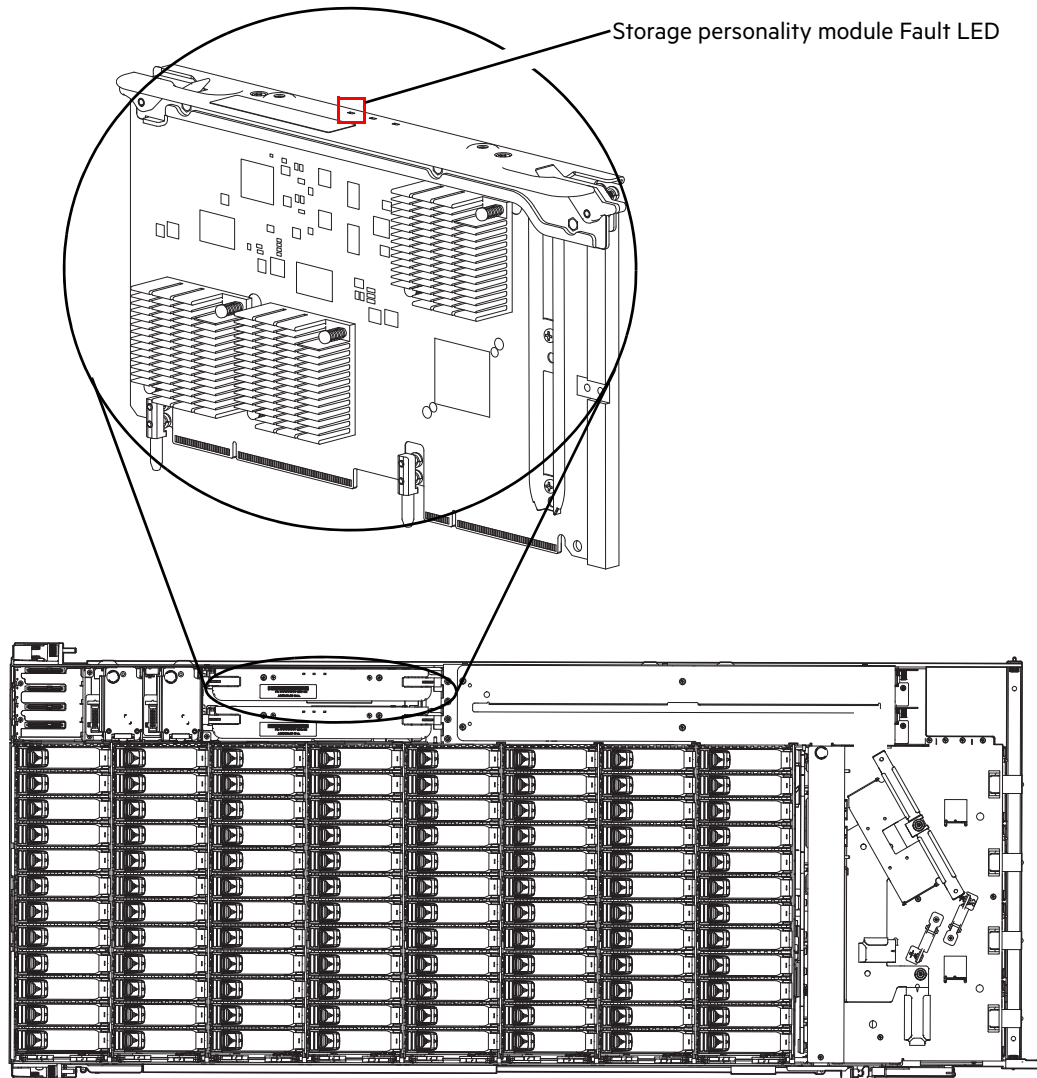

Module LED	LED behavior states	
Storage personality module fault LED	SPM OK (OFF)	SPM Fault (amber)

Figure 24 Storage personality module LED location

HS Expander module

Each HS expander module has two LEDs: LED 2 and LED 3 and they are located at the circuitry side which faces chassis sidewall (See [Figure 25](#)). You can see the reflections of these LED lights on the chassis sidewall and accordingly, can determine the status of the expander module.

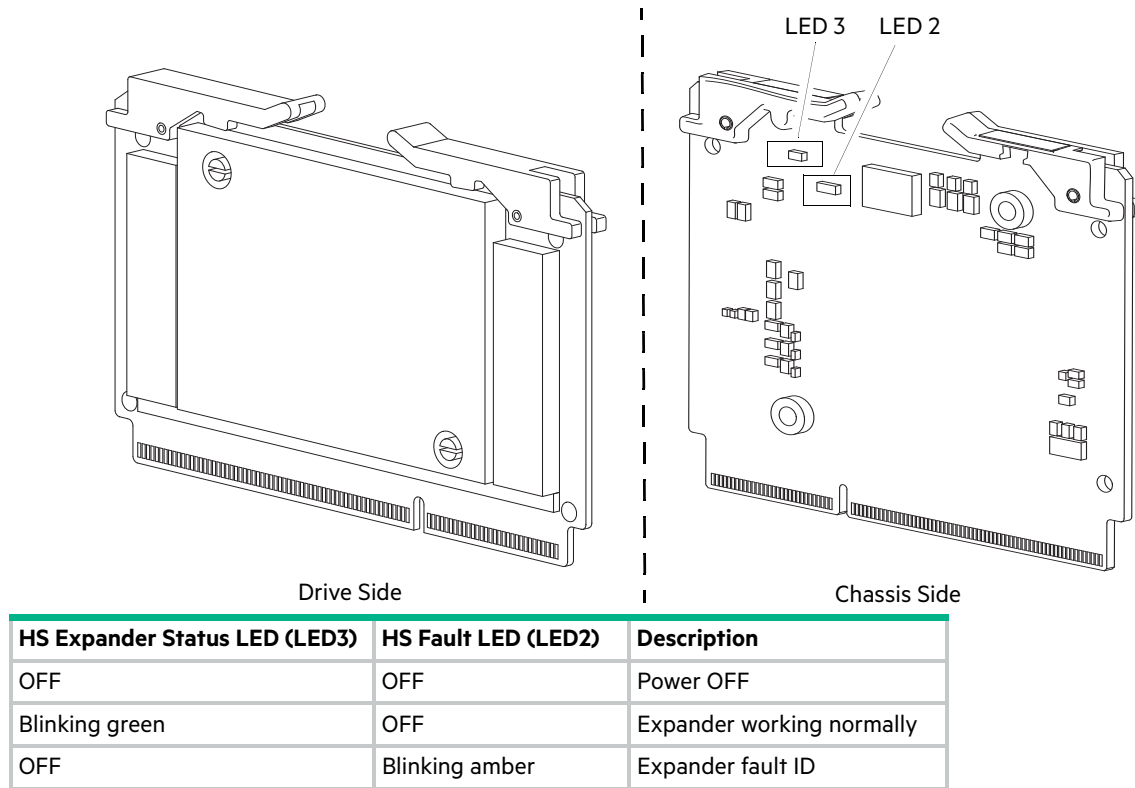

Figure 25 LEDs: HS Expander module

Enclosure management

The BMC in a Controller module works with the expanders in the Storage Personality Module and the HS Expander Modules to manage the enclosure. The BMC supports the ANSI SES standard by offering a SES target, and the Intelligent Platform Management Interface (IPMI) standard. If the enclosure has two Controller modules, the BMCs work together to manage the enclosure.

See a module's specification or the SES Interface specification for definitions of the module's functions and its SES control.

The storage system also provides a command-line Interface (CLI).

GEM Command-line interface (CLI)

The Generic Enclosure Management Command Line Interface (GEM CLI) can be accessed in the following ways:

- Serial port connection
- Ethernet Telnet connection
- Ethernet WBCLI utility
- SESCLI utility

The CLI utilities and capabilities are described in the GEM Command-line Interface document. Contact your system engineer for additional information.

3 Installation

Installation checklist

This chapter shows how to plan for and successfully install your enclosure system into an industry standard 1.2 m rack cabinet.

⚠ CAUTION: To install the system, use only the power cords supplied, or power cables that match the specification quoted in “AC power cords/universal jumper cords” (page 116).

The following table outlines the steps required to install the enclosure. To ensure successful installation, perform the tasks in the order presented. For rackmount installation, temporarily place all drive modules in a static-protected area, and then install them after the 4U100 is installed in the rack.

Table 4 Installation checklist

Step	Task	Where to find procedure
1	Plan for installing the 4U100 into the rack ¹	See “Planning for installation” (page 45).
2	Prepare for installing the 4U100 into the rack ¹	See “Preparing for installation” (page 46).
3	Install rack mount rail kit Attach inner rails to the 4U100 enclosure	See “Installing the rack mount rail kit” (page 52). See “Attaching inner rails to the storage enclosure” (page 61).
4	Install the 4U100 enclosure into the rack space	See “Mounting the storage enclosure into the rack cabinet” (page 63).
5	Install the CMA and crossbar Install drives into 4U100 enclosure	See “Installing the CMA and crossbar” (page 66). See “Installing drives” (page 69).
6	Cable the 4U100 enclosure to the compatible expansion enclosures	See Figure 66 and Figure 67 (page 78).
7	Connect power cords	See “Power cord connection” (page 79).
8	Test enclosure connectivity	See “Testing enclosure connections” (page 79).

¹The environment in which the enclosure operates must be dust-free to ensure adequate airflow.

Planning for installation

Before beginning the enclosure installation, familiarize yourself with the system configuration requirements. The figures listed below show the locations for each plug-in module:

- 4U100 enclosure front panel: see Figure 3 (page 22)
- 4U100 enclosure rear panel: see Figure 4 (page 23)
- 4U100 enclosure top: see Figure 10 (page 27), Figure 13 (page 29), and Figure 14 (page 30)

ⓘ IMPORTANT: Installation work should be performed by qualified service personnel.

Table 5 Storage system configuration

Module type	To be accessed from	Description
Power supply unit	Rear panel	Two PSUs provide full power redundancy, allowing the system to continue to operate while a faulty PSU is replaced.
System fan	Rear panel	Four system fans provide cooling, allowing the system to continue to operate while a faulty system fan is replaced.
Controller module	Rear panel	Two Controller modules of the same model are present. Each Controller module enables the enclosure to act as a server and provide an environment for enclosure management. Also, each Controller module slot can support one blank.
Storage personality module	Top	Two Storage personality modules - one connected to each controller module - that provide SAS connections to SSDs, HS expanders, and expansion ports.
Drive module	Top	Up to 100 drives (96 LFF and 4 SFF), each having a carrier that protects the drive and passes signals from the baseplane to LEDs atop the carrier. Refer “Populating drive slots” (page 30) .
Controller channel fan	Top	Up to two channel fan modules of the same model type are supported to cool controller channel bay.
HS expander	Top	Eight removable hot swap expanders are supported: two for each 24-drive baseplane.

Preparing for installation

⚠ CAUTION: The 4U100 enclosure—together with all its CRUs except the drives—is too heavy for one person to lift. The enclosure weighs 56 kg (123.45 lbs) excluding rails, CMA, and the drives. It weighs 142 kg (313 lbs) including all CRUs. A minimum of four people and a suitable mechanical lift are required to hoist the enclosure and install it into the rail kit assembly within the rack.

Make sure you wear an effective anti-static wrist or ankle strap and obey conventional ESD precautions when touching modules and components. Do not touch midplane, motherboard, or module connectors. See [“ESD precautions” \(page 89\)](#).

This section provides important preparation requirements and handling procedures for use during product installation.

Preparing the site

Before beginning the enclosure installation, verify that the site where you will install your storage system has the following:

- A mechanical lift that can safely hoist a 70 kg (155 lbs) high-density enclosure for installation into a 1.2 m rack.
- A proper redundant AC power source or a rack power distribution unit (PDU).
- Network switch to access the enclosure.
- An electrostatic discharge (ESD) protected environment for temporarily storing CRUs and drive modules if the enclosure is intended for rackmount use. See the **CAUTION** on [page 16](#) before unpacking the enclosure and installing it in the rack.

Before installing the enclosure, verify the existence of the following:

- Qualified cable options for host connection and expansion enclosures
- Two C14-to-C13 power cables per PSU (total 4 cables per 4U100 enclosure) having minimum length of 2.5 meters

- Rail kit and Cable Management Arm (for rack installation and cable management)
- Drive modules for use in populating the disk slots after the enclosure is secured into the rack

See your supplier for a list of qualified accessories for use with the enclosure. The accessories box contains the power cords and other accessories.

Unpacking the enclosure

Before unpacking the enclosure, familiarize yourself with the exploded view of packaging components that pertain to 4U100 enclosure. See “[Enclosure packaging](#)” (page 118).

1. Examine the packaging for crushes, cuts, water damage, or any other evidence of mishandling during transit. If you suspect that damage has happened, photograph the package before opening, for possible future reference. Retain original packaging materials for use with returns.
2. Follow the unpacking sequence pertaining to 4U100 enclosures as shown in the [Figure 98](#) (page 120) and [Figure 99](#) (page 121). Removing packaging materials like lids, inerts, and side walls improve accessibility of the lifting personnels as they don't need to bed over a lot over packaging and to lift the enclosure as high up.

△ **CAUTION:** The enclosure does not ship with drive modules installed, but all other modules are installed. This partially populated enclosure is quite heavy: 57 kg (126 lbs).

You can remove the enclosure from its shipping box using the standard belt-style lifting straps. If available, you can remove the enclosure from its box using the optional lift handles instead of the straps.

- a. Default method: remove the enclosure from its box using the straps.

See [Figure 26](#) (page 47) and the **CAUTION** above and below the illustration. The illustration shows buckled belt-straps secured longitudinally on the 4U100 enclosure. Only the straps and plastic bag are shown. They are isolated from the remainder of the packaging. See “[Enclosure packaging](#)” (page 118) for more information about the packaging materials.

△ **CAUTION:** Remove the plastic bag and keep it out of the way. Verify that each strap is securely wrapped and buckled to the enclosure before performing the lift.

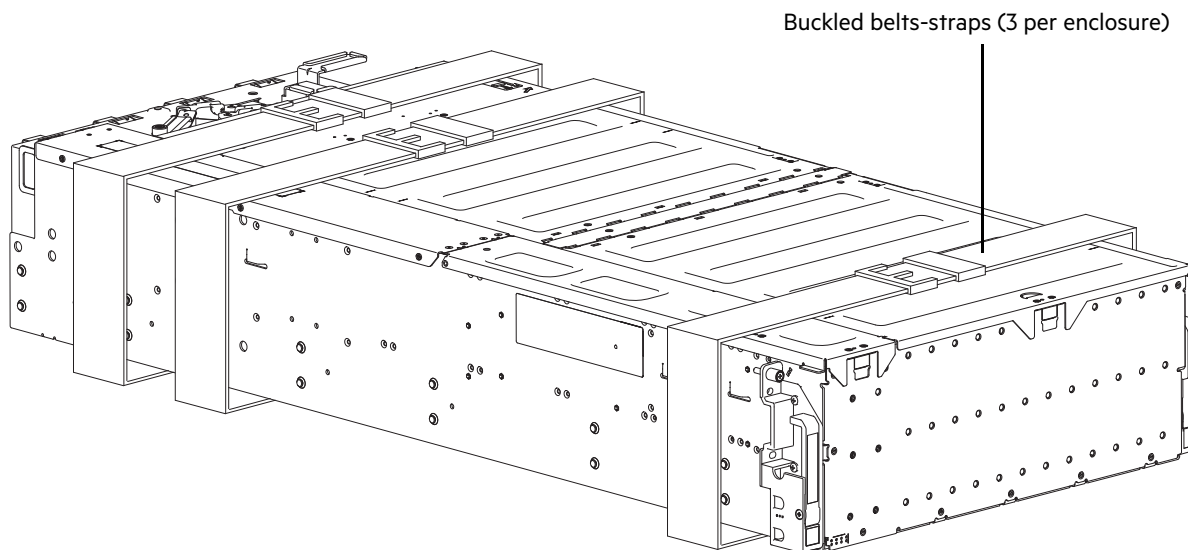

Figure 26 Unpacking the 4U100 enclosure using straps

CAUTION: With four persons—positioned one at each corner of the enclosure—grip the straps securely by the loops, and lift the enclosure out of the box using appropriate lifting technique. Place the enclosure in an ESD protected area.

Except for the drive modules, enclosures are supplied with all integrated PCBs and all plug-in modules installed. For information about plug-in module replacement, see “[Module removal and replacement](#)” (page 89). Drive modules are installed separately *after* the enclosure is mounted in the rack.

Upon completion of this step, go to [step 6](#) on [page 51](#).

b. Alternative method: remove the enclosure from its box using the optional lift handles.

[Figure 27](#) shows left, and right lift handles along with their slots present on the enclosure sidewalls. Each 4U100 enclosure supports four lift handles (two identical lift handles on the left sidewall, and two identical lift handles on the right sidewall). Carefully mark the difference between the left and right lift handles, and their slots present on the enclosure.

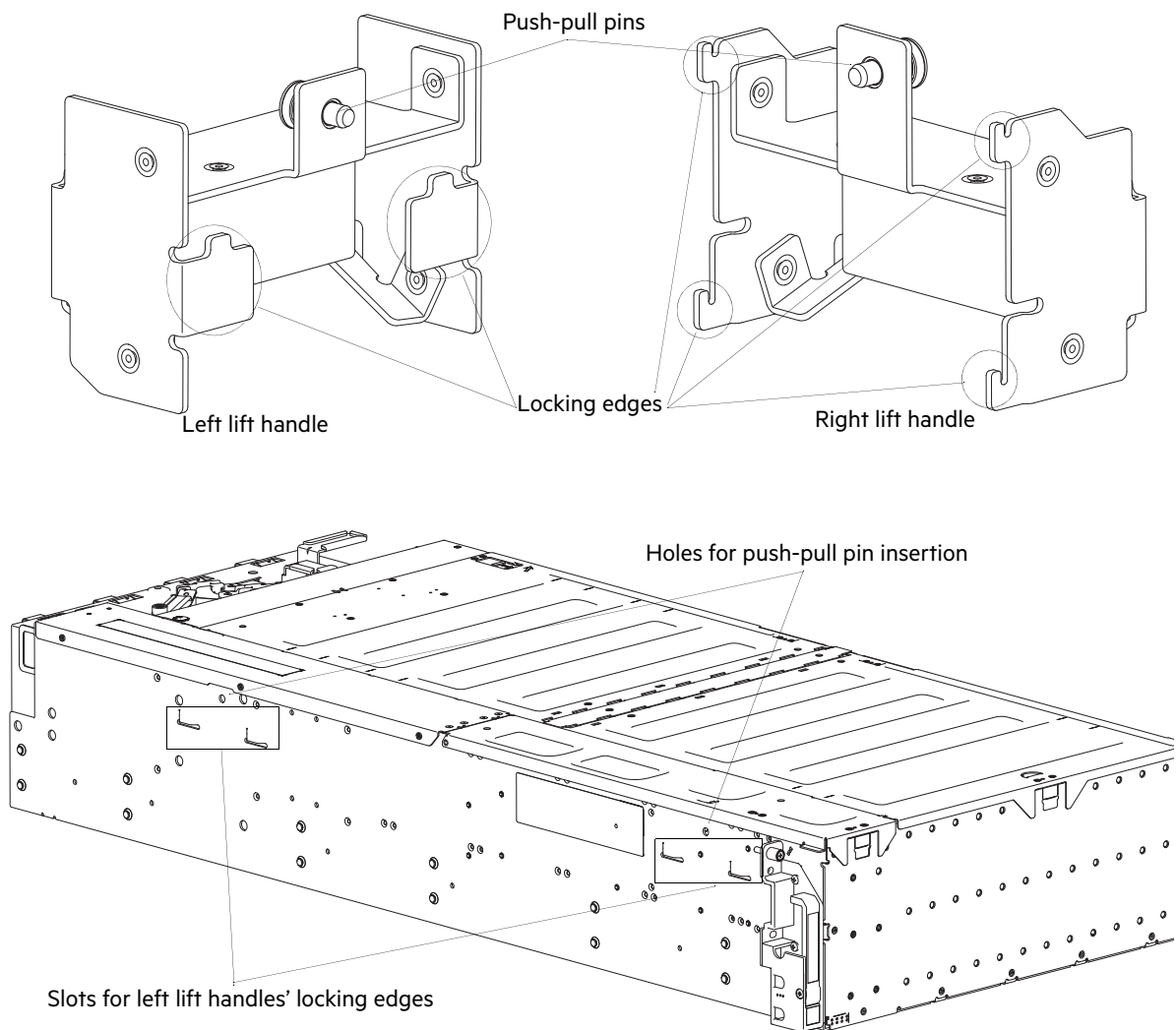

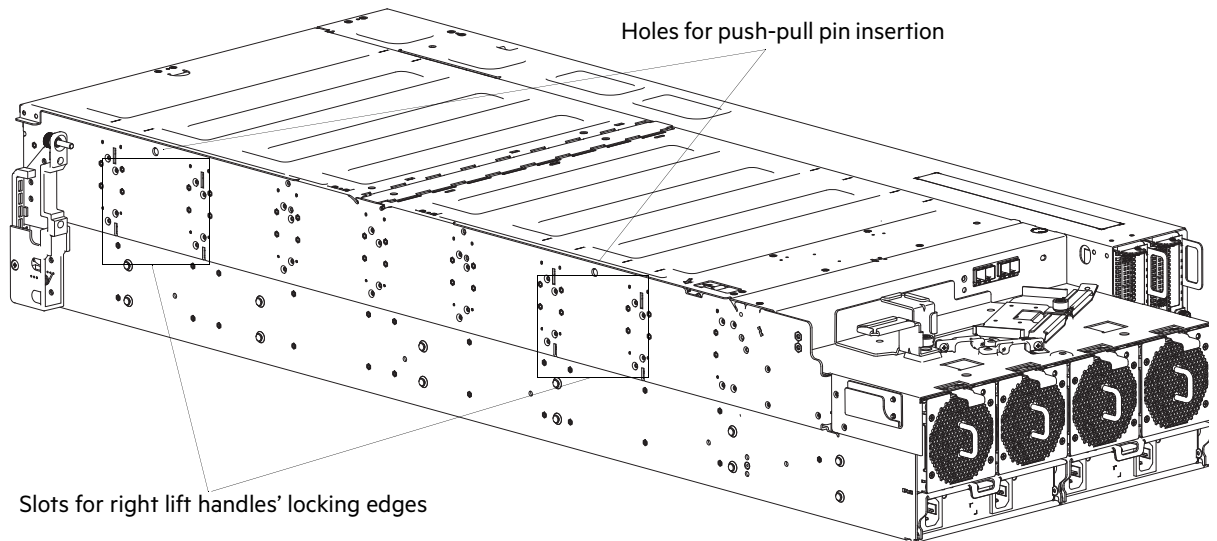

Figure 27 Lift handles and their slots present on the enclosure

See [Figure 30 \(page 51\)](#) and the **CAUTION** above and below the illustration. Illustrations are isolated from the remainder of the packaging. As a visual aid for the unpacking task, see “[Enclosure packaging](#)” ([page 118](#)). The illustration shows lift handles slots present at the front of the enclosure. Similar slots are present at the rear of the enclosure. The bottom illustration shows two steel lift handles installed on the left side of the chassis just below the enclosure lid.

To attach the left lift handles to the enclosure chassis follow the steps below.

△ CAUTION: Remove the plastic bag present on the enclosure and keep it out of the way before attaching the lift handles.

1. Identify the left lift handles (see [Figure 27](#)) (quantity 2), and remove them from the packaging box.
2. To attach the front left lift handle, align it in below the front left lift handle slots present on the left sidewall of the enclosure as shown in [Figure 28 \(page 50\)](#).

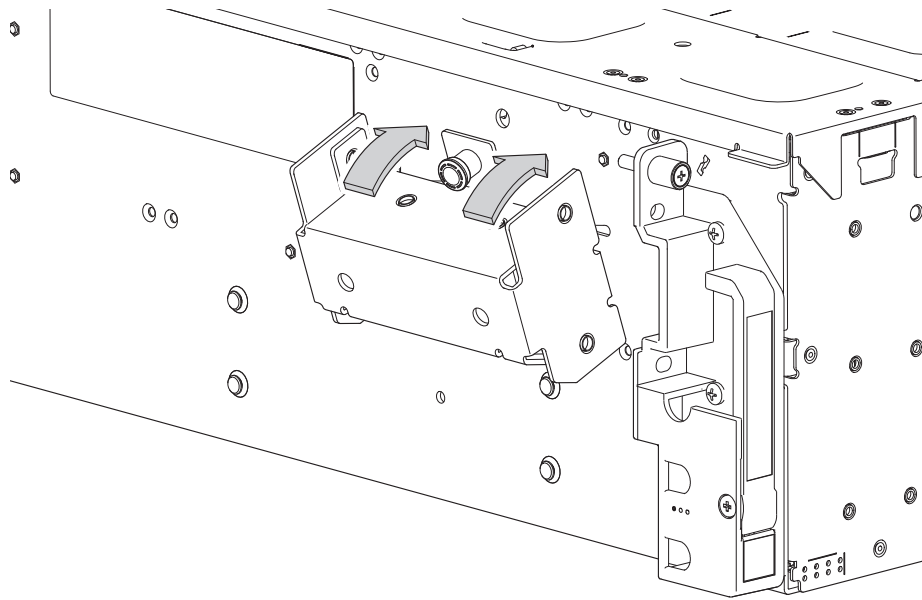

Figure 28 Aligning front left lift handle to the enclosure slots

3. Hold the lift handle flat against the enclosure sidewall and slide it upward till the push-pull pin gets engaged into the push-pull pin hole. This push-pull pin along with the lift handle locking edges, locks the lift handle firmly against the enclosure sidewall.

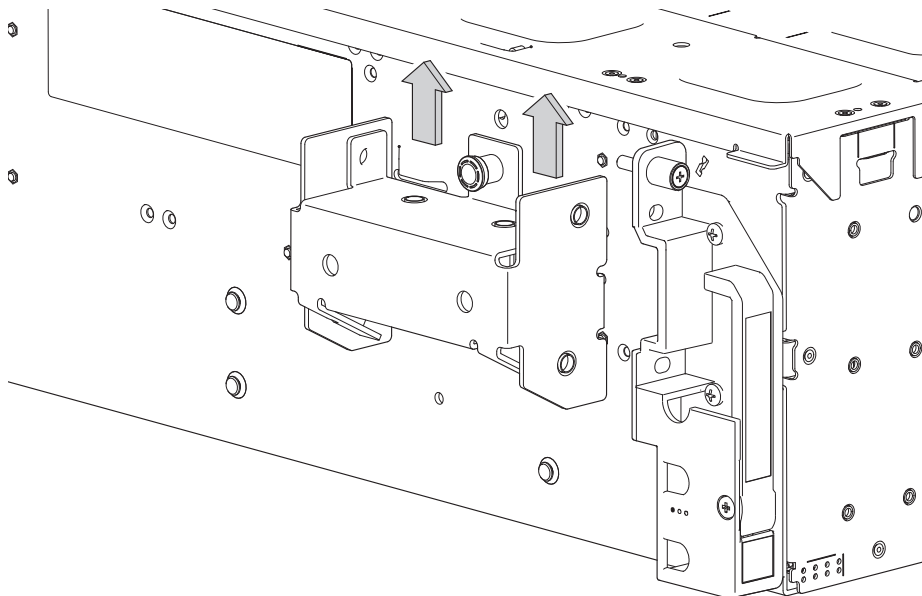

Figure 29 Sliding the front left lift handle upward

4. Follow the [step 1](#) through [step 3](#) and attach the second left lift handle to the another slot present on the left sidewall of the enclosure.
5. Follow [step 1](#) through [step 4](#) to attach the right lift handles on the right sidewall of the enclosure.

-
- △ **CAUTION:** Verify that each of the four lift handles is securely fastened to the enclosure sidewalls (sheet metal) before performing the lift.
- These handles are designed to support the weight of a partially populated enclosure: chassis and CRUs only (as shipped). The handles are not designed to hold the weight of a fully populated enclosure which includes the drives.
-

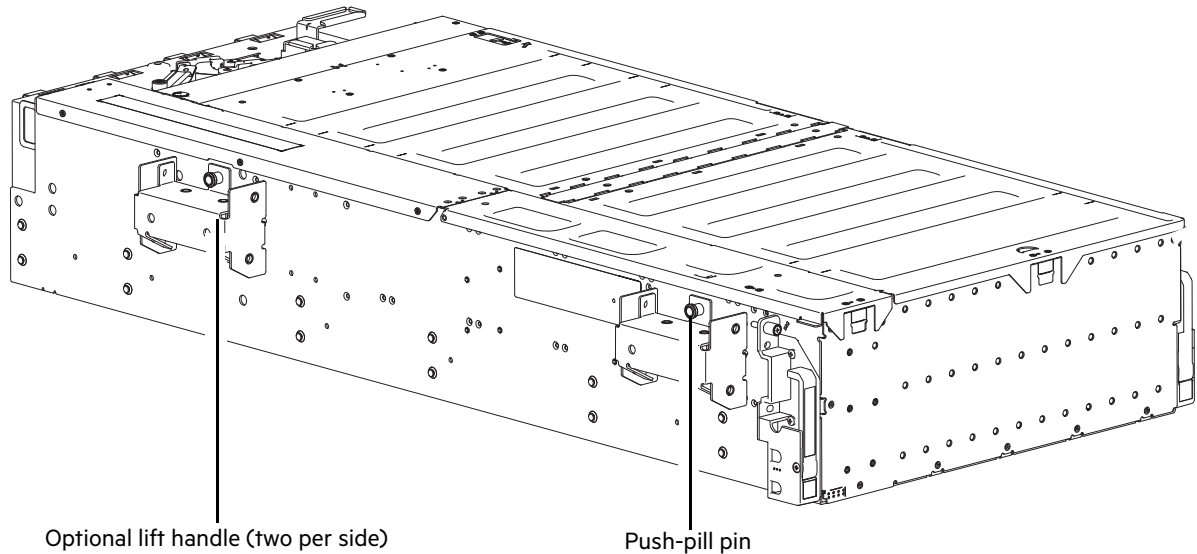

Figure 30 Attached lift handles

-
- △ **CAUTION:** With four persons—positioned one at each corner of the enclosure—grip the handles securely, and lift the enclosure out of the box using appropriate lifting technique. Place the enclosure in a ESD-protected area.
- Except for the drive modules, enclosures are supplied with all integrated PCBs and all plug-in modules installed. For information about plug-in module replacement, see “[Module removal and replacement](#)” (page 89). Drive modules are installed separately *after* the enclosure is mounted in the rack.
-

6. Prepare to install and set up the enclosure.
 - a. Before installing the enclosure into a rack, see the **CAUTION** on [page 16](#) and the **WARNING** on [page 63](#).
 - b. For rackmount installation, do not install the drive modules until the enclosure is mounted into the rack.

Complete installation prerequisites

The rack mount rails are designed to bear the maximum weight of the storage enclosure when it is properly mounted in a standard rack cabinet. You can install multiple storage enclosures in a single rack cabinet depending upon availability of empty rack space.

⚠ CAUTION: You must use only the supplied rail kit and Seagate recommended mounting hardware. Contact your supplier to ensure suitable mounting rails are available for the rack you are to use.

To complete installation prerequisites:

1. Prepare the host system for the installation. Have access to the following items:
 - a. A functioning SAS host bus adapter
 - b. Known good cables for host connection that meet storage enclosure requirements
 - c. A minimum of one power cord that matches power control module specifications
2. Familiarize yourself with system configuration requirements and the layout of storage enclosure modules.
3. Obtain the following:
 - a. An anti-static wrist or ankle strap for handling ESD-sensitive components
 - b. A static-protected environment for temporary storage of the storage enclosure and then the disk drives
 - c. #2 Phillips-head magnetic screwdrivers, 6- and 12-in. length
 - d. T10 and T25 Torx torque driver, 6-in. length
 - e. A retractable tape measure
 - f. A mechanical lift with sufficient clearance and capable of safely lifting the unpopulated storage enclosure
4. Ensure the rack cabinet is suitable for use with the storage enclosure.
 - a. A rack cabinet capable of holding 4U form factors
 - b. A maximum depth of 47.5 in. (1,206.5 mm) from post to maximum extremity, including cabling
 - c. A rack cabinet that causes a maximum back pressure of 5 pascals (0.5 mm water gauge)
 - d. Minimum weight capacity of up to 321 lb. (146 kg) per storage enclosure
 - e. A rack cabinet leveled in all planes with respect to each other
5. Secure sufficient staff to assist with the installation. Minimum staff:
 - a. One qualified service technician for the complete installation procedure
 - b. One spotter to assist with the lift, make sure the inner rail fully mates with the mid rail, then observe and possibly assist with the installation of the rear outer rails from the rear of the rack cabinet
 - c. A total of four people to unpack the storage enclosure and move it onto the lift

Installing the rack mount rail kit

The rack mount rail kit contains a left and right rail. Product function and user safety is highly dependent on proper installation of rail kit.

Separating the inner rails from the outer and mid rails

⚠ WARNING! Carefully inspect the rails. Do not use damaged or warped rails. If found damaged, return the rails in the same packaging material. Rail failure can allow the storage enclosure to fall and result in a serious injury since the load on them can exceed 321 lb (146 kg).

The rails ship with the inner rails inside each of the outer and mid rail sub-assemblies. You must separate them before attaching outer and mid rail sub-assemblies to the rack cabinet and inner rails to the storage enclosure.

Required equipment	Quantity
Rail assemblies in packaging	2
Rail end caps in packaging	2

To separate the inner rails from the outer and mid rail sub-assemblies:

1. Complete the following actions to remove the rail assemblies from their packaging:
 - a. Orient the left rail with the L embossed on it to your left.
 - b. Orient the right rail with the R embossed on it to your right.
 - c. Locate to the top of each rail, so the embossed arrow points upward.
2. Examine the rails to distinguish each component, particularly the ball bearing retainer and mid rail.

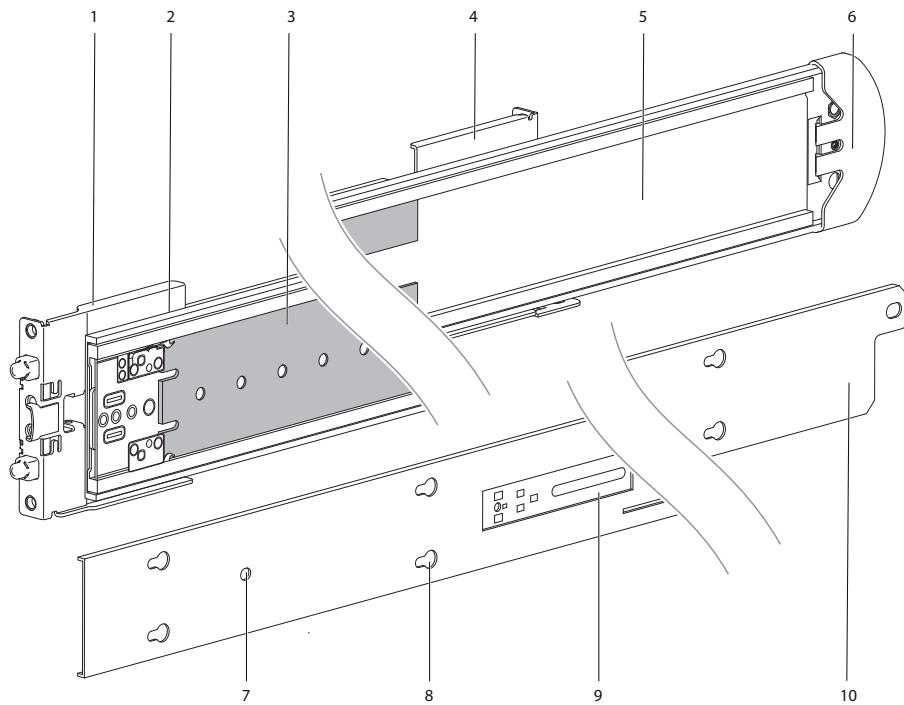

Figure 31 Separated left rail assembly, inner sides facing

Item no.	Description	Item no.	Description
1	Front mount bracket	6	End cap
2	Outer rail, top-side up	7	Slotted screw holes
3	Ball bearing retainer	8	T-pin keyholes
4	Rear mount bracket	9	Safety lock
5	Mid rail, slides within outer rail	10	Inner rail, top-side down

3. (Optional) Locate the outer rail end caps and clip each end cap into the slots at the rear outer side of each rail.
4. Extend the mid and inner rail on the outer rail of the left rail assembly until the safety lock engages with a click.

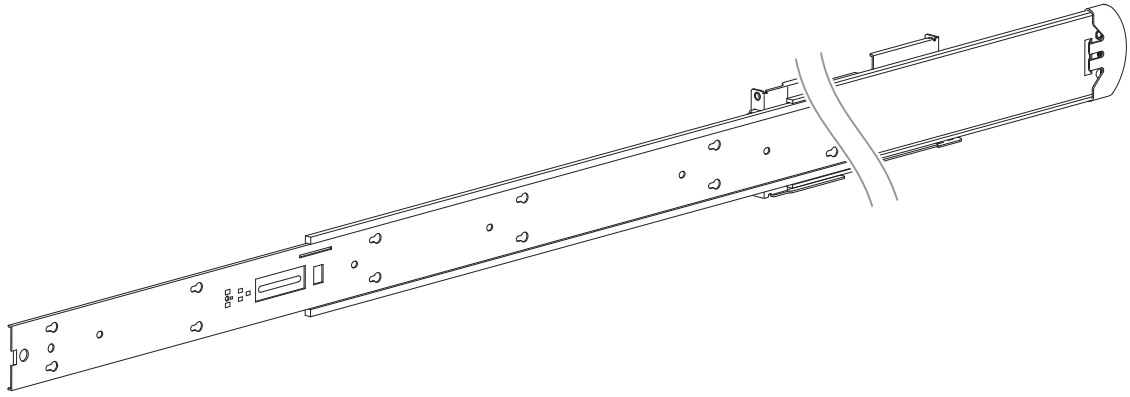

Figure 32 Extending Left inner rail beyond mid rail

5. Turn the left rail assembly over, then press the safety lock to disengage the inner rail.

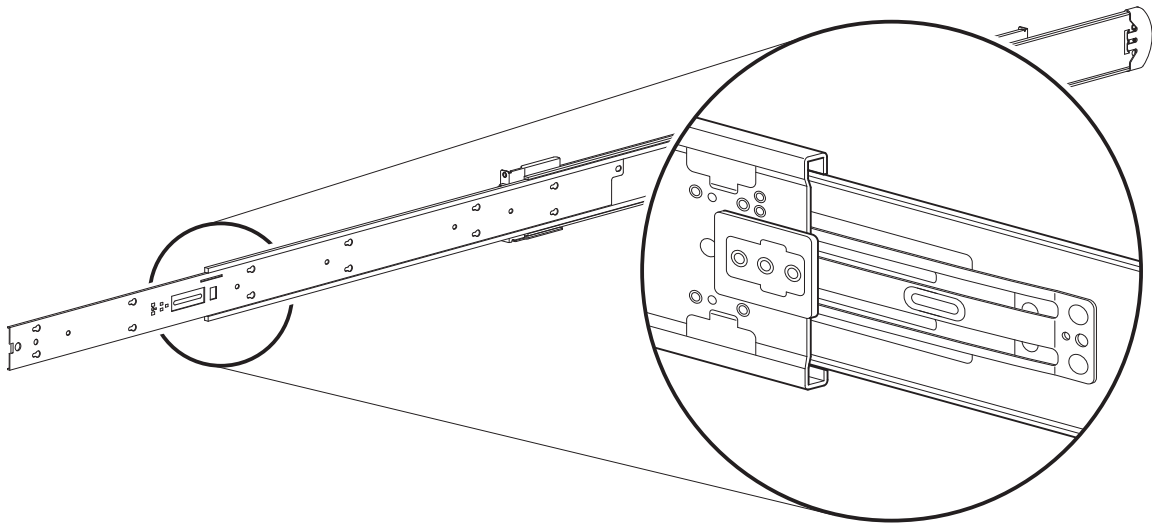

Figure 33 Location of inner rail safety lock

6. Slide out the left inner rail until it separates from the outer and mid rail sub-assembly, setting it aside.
7. Turn the left outer and mid rail subassembly back to its original position, then locate the mid rail release switch.

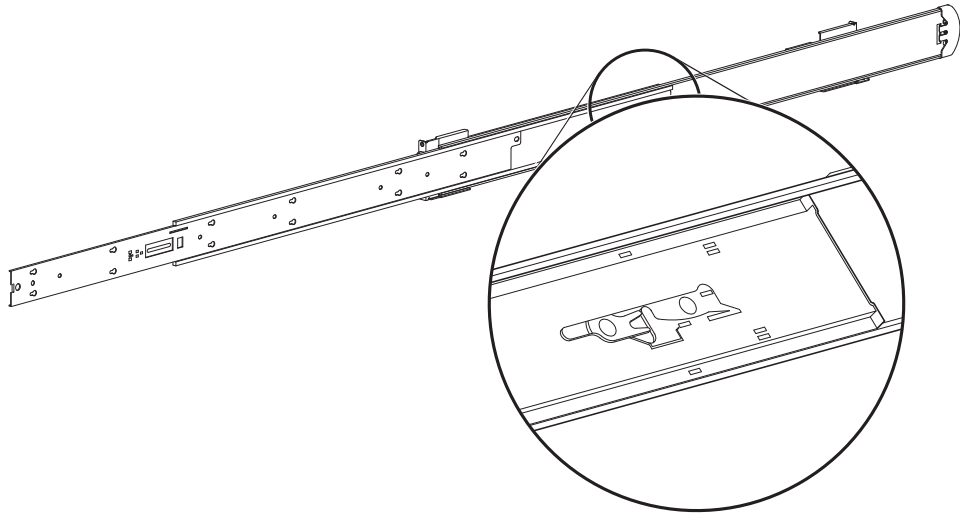



Figure 34 Location of mid rail release switch lever

8. Rotate the mid rail release switch lever to release it, then slide the left mid rail back until fully retracted onto the outer rail.
9. Set aside the left outer and mid rail subassembly near the left inner rail.
10. Separate the right rail using the same process, keeping the separated right rails in an alternate location as the mirror image of the separated left rails.
11. Once again, inspect the rails for any damage or warping. If you locate either, return them in their original packaging.

Adjusting the outer rails to the rack cabinet

Rack cabinet configurations vary widely. Make sure the rack cabinet meets the storage enclosure prerequisites and the rack cabinet doors will fully close with the proper clearance before you begin this task. You must correctly attach the outer rails to the rack cabinet. After successful installation of the rails, the storage enclosure must slide smoothly on the rails from fully inserted out to the service position and back again.

Required equipment	Quantity	Identification
Outer rails, properly oriented	2	N/A
A retractable tape measure	1	N/A
#2 Phillips-head screwdriver 6-in. length	1	N/A
Panhead screw M4x4mm length	4	
CMA B bracket	1	

To adjust outer rails to the rack cabinet:

1. Facing the rack cabinet, measure the post-to-post depth distance between the inner sides of the rear and front rack posts.

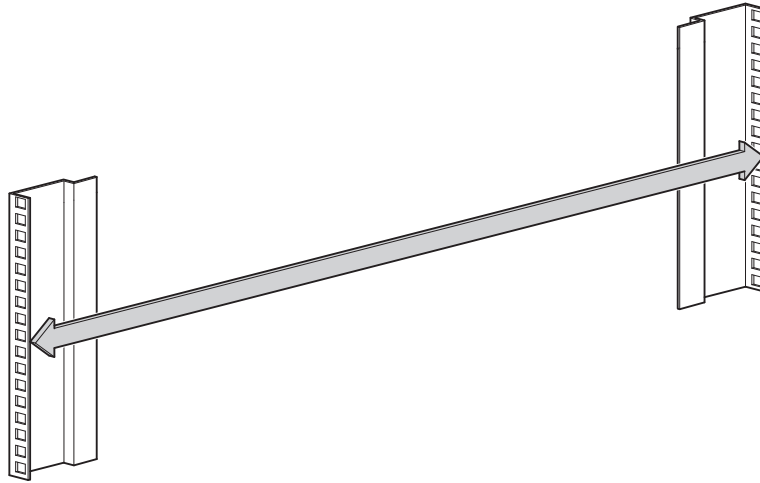

Figure 35 Measurement of rack post-to-post inside-depth distance

2. Select the left outer rail assembly, rotating it so you face the mid rail, not the outer rail.
3. Rotate the mid rail release switch, then extend the mid rail until it locks.
4. If the distance you measured is not between the default 34 inches and 35 inches, use a #2 Phillips-head screwdriver to remove and set aside all four rear mount bracket setscrews.

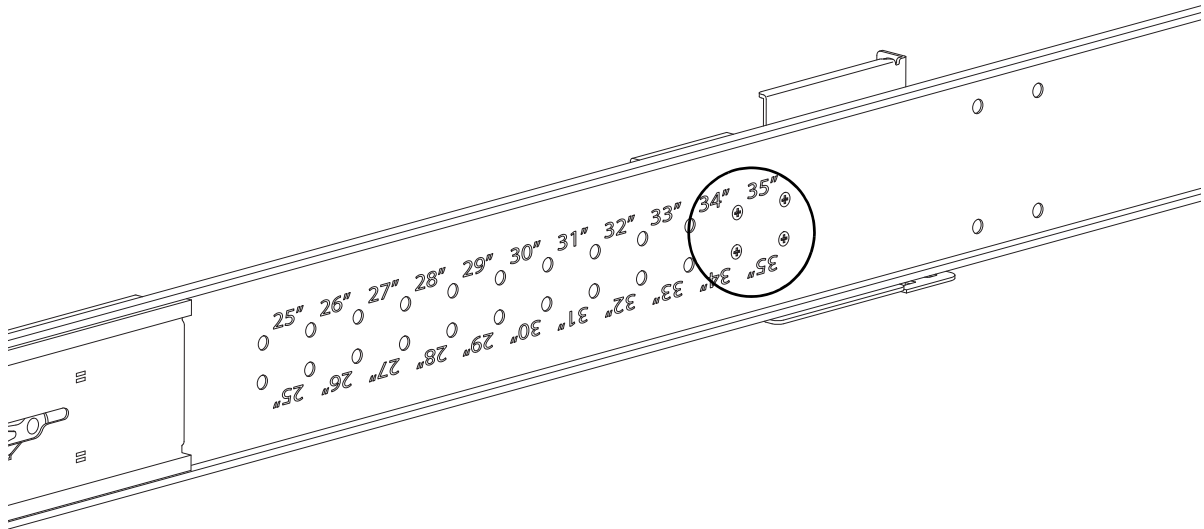

Figure 36 Default location of outer rail adjustment setscrews

5. Measure the rail distance from the inside of the front mount bracket to inside of the back mount bracket to determine if it matches the distance between rack posts.

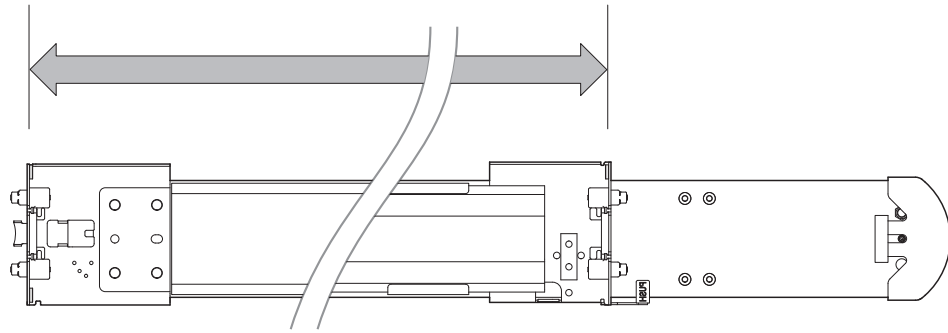

Figure 37 Measurement of rail from rear to front mount bracket

6. Relocate the rear mount bracket to within an inch of the post-to-post depth distance you recorded, aligning the rear mount bracket holes to the demarked holes on the outer rail. For example, if you recorded 27.5 inches, you would use the 27-inch and 28-inch holes marked on the rails.

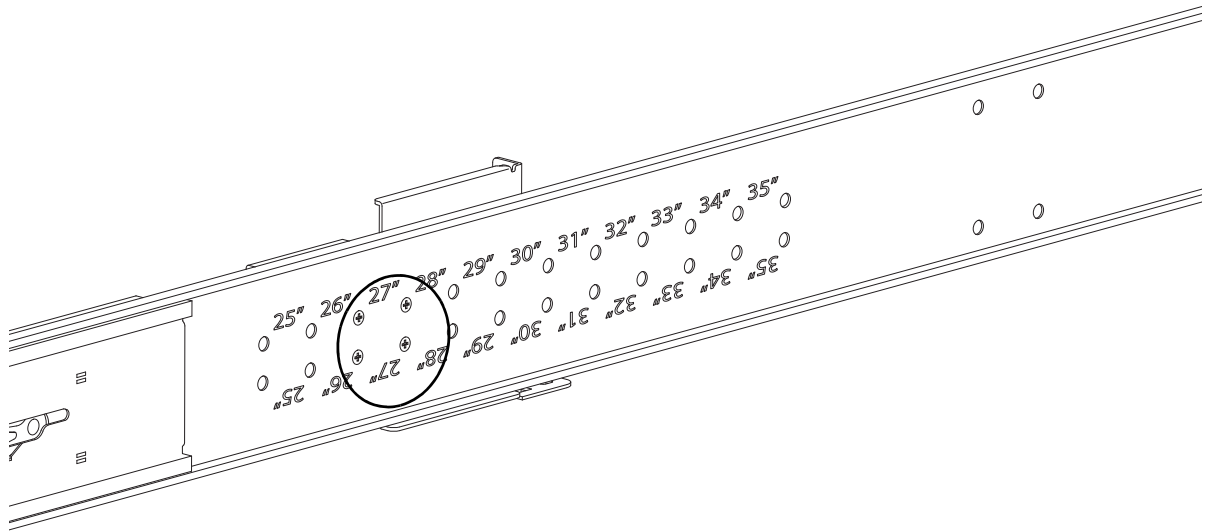

Figure 38 Sample adjustment adjusted depth distance for rear-mounting bracket screws

7. Insert and tighten each screw to a torque of 12 lbf-in (1.36 N-m), then perform a fit check to validate the correct rail length.
8. Repeat the process for the right outer rail, using the proper orientation for the rack cabinet and rail.
9. Turn over the right outer rail assembly to access the inner side of the rear outer rail, locating the CMA B bracket attachment holes.

ⓘ **IMPORTANT:** Orient the rail with the bracket front to your left, the rounded rear of the bracket to your right, and the outer rail away from you.

10. Locate the CMA B bracket in the CMA box.
11. Attach the CMA B bracket with the proper orientation to the right outer rail using four (4) M4 panhead screws, tightening with a #2 Phillips-head screwdriver to a torque of 18 lbf-in (2.0 N-m).

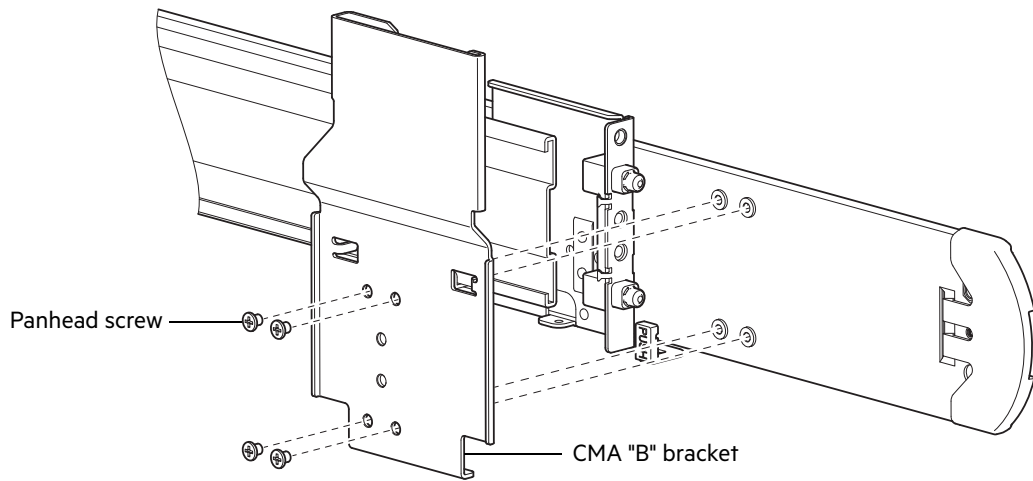

Figure 39 Alignment of CMA B bracket

Installing the outer rails in the rack cabinet

⚠ WARNING! If you do not properly install and securely fasten the rack rails according to this procedure, you risk serious personal injury and could damage the storage enclosure.

Attach the outer rack rails to the rail cabinet in 4U increments. Select the location for the outer rails based on the following factors:

- Rack system safety precautions
- Position in the rack
- Population of the storage enclosure, full or partial

Once you determine the appropriate position in the rack cabinet, reread the rack system safety precautions, then proceed to install the outer rails. The following task assumes your rack posts have square mounting holes.

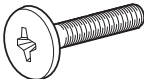
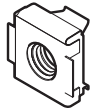
Required equipment	Quantity	Identification
Outer rails, properly oriented	2	N/A
#2 Phillips-head screwdriver, 12-in. length	1	N/A
Truss head screws, 10-32x3/4 in. length	10	
Cage nut, 10-32for rack posts with square mounting holes	4	

To install the outer rails in the rack cabinet:

1. Verify that you assembled the rack rails according to prior tasks, orienting it with embossed arrows pointing upward.
2. Complete the following actions to insert the right outer rail assembly as shown to attach it to the rear post on the right side of the rack cabinet:
 - a. Insert the right outer rail assembly into the rack, adjusting the rear mounting bracket to the bottom of the allotted 4U space.
 - b. Clip the rear mounting bracket spring onto the rear rack post, then confirm that the mounting bracket seats fully into the rear rack post mounting holes.
 - c. Secure the rear rack rail flange to the rack column with two Truss head screws, then tighten each screw with a #2 Phillips-head screwdriver to a torque of 35 lbf-in (3.95 N-m).

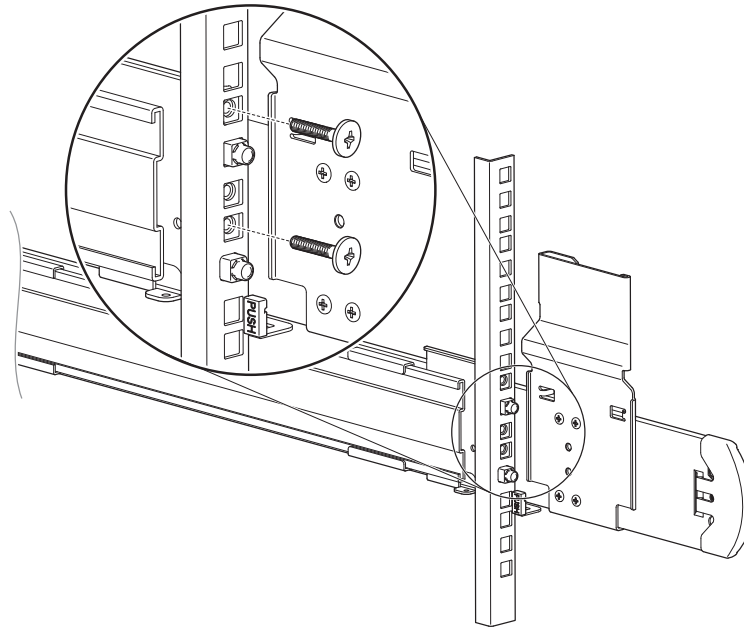

Figure 40 Attach the rear of the outer right rail assembly

3. Complete the following actions to attach the front of the right outer rail assembly to the right front post of the rack cabinet:
 - a. Slide the front mounting bracket into the front rack post so that it occupies the bottom of the allotted 4U space.
 - b. Clip the front mounting bracket spring onto the front rack post so that the outer sleeve, which mates to either a round or square mounting hole, snaps fully into place.
 - c. Confirm that the mounting bracket fully seats in the mounting holes by verifying that the outer sleeve fully extends and is flush with the fixed inner pin.

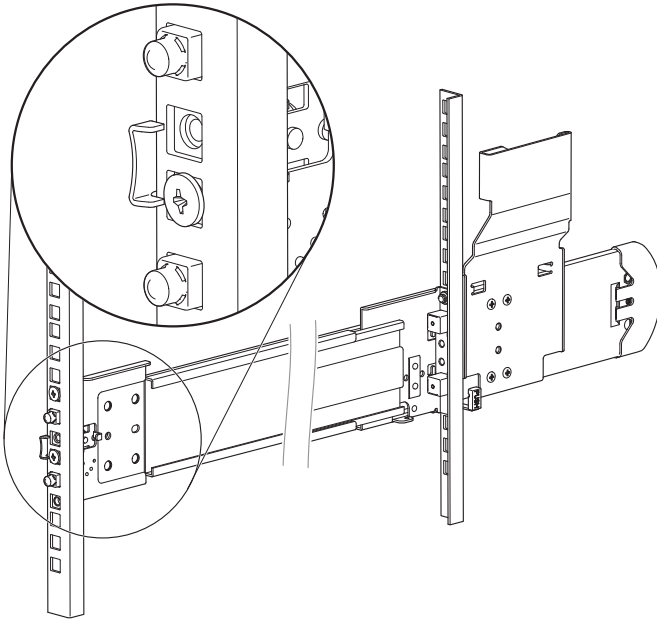

Figure 41 Right front post detail of the inserted outer right rail assembly

- d. Confirm the latch on the front rack rail mounting bracket snaps onto the front rack post.
 - e. (Optional) To release the front mount bracket, press the keyed latch outward and realign the rail.
 - f. Insert a Truss head screw in the hole just below the bottom rail pin seated in the rack post.
 - g. Secure the front mount bracket by tightening the screw with a #2 Phillips-head screwdriver to a torque of 35 lbf·in (3.95 N·m).
4. Insert a cage nut in each front rack post at the second-from-the-top hole in the allocated 4U space, then make sure the nut spring is fully engaged in the post hole.

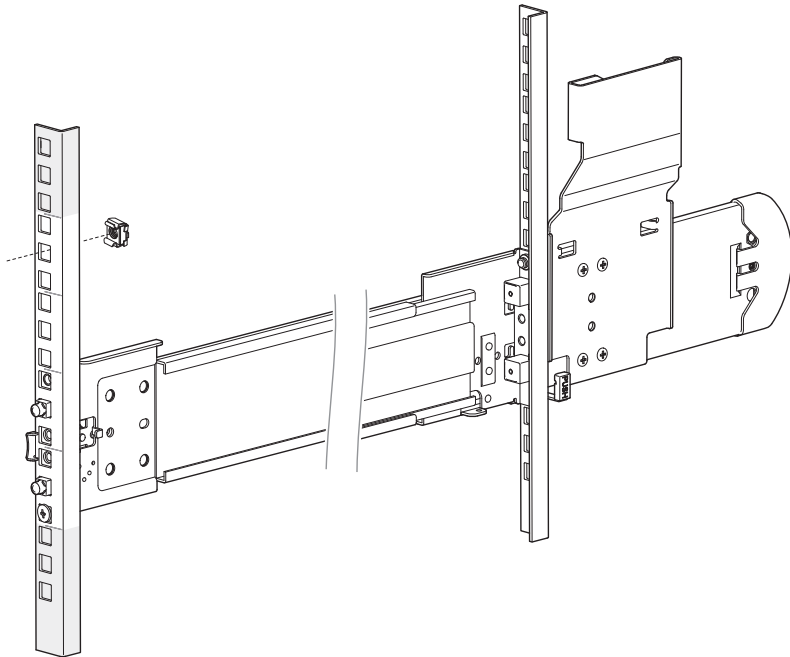





Figure 42 Location of cage nuts

- 5. Repeat the entire procedure for the left outer rail assembly.

Attaching inner rails to the storage enclosure

You must correctly attach the inner rails to the storage enclosure to bear the weight of its contents.

Required equipment	Quantity	Identification
Inner rails, properly oriented	2	N/A
T10 Torx torque driver, 6-in. length	1	N/A
M3 low profile screws, 5x2.75-in. length	10	
#2 Phillips-head screwdriver, 6-in. length	1	N/A
Panhead screw, M4x4mm length	2	
CMA A bracket	1	

To attach inner rails to the storage enclosure:

1. Examine the inner rails, locating the smooth inner edge of the rail, the flanged outer edge, and the top notch at the rear of each.

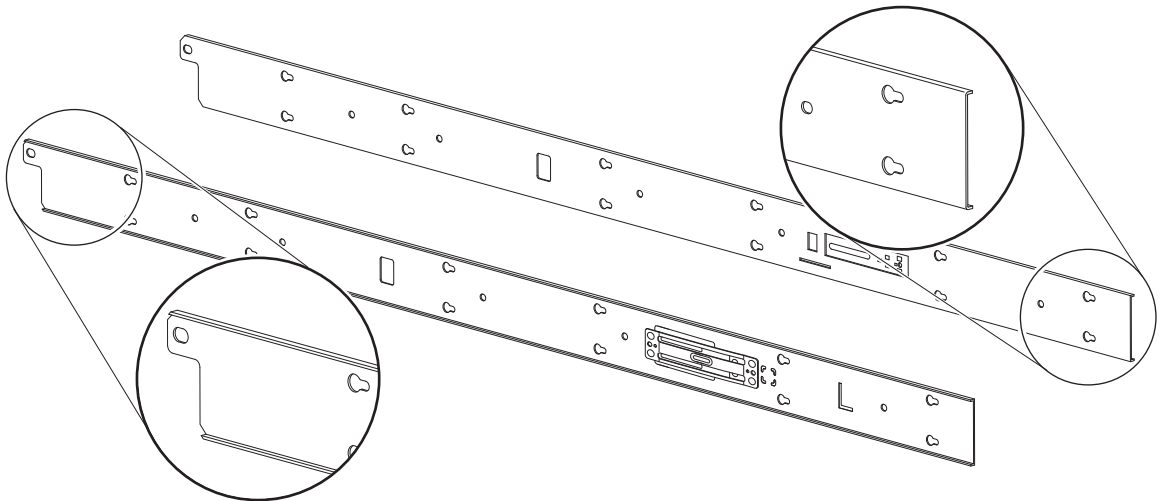

Figure 43 Left and right inner rail edge details

2. Orient the left inner rail so that the flat face at the front of the rail is to your right, the top notch is to your left, and the smooth inner edge away from you.
3. Face the left sidewall of the storage enclosure, then align the left inner rail's key holes to the six pairs of sidewall Tpins.

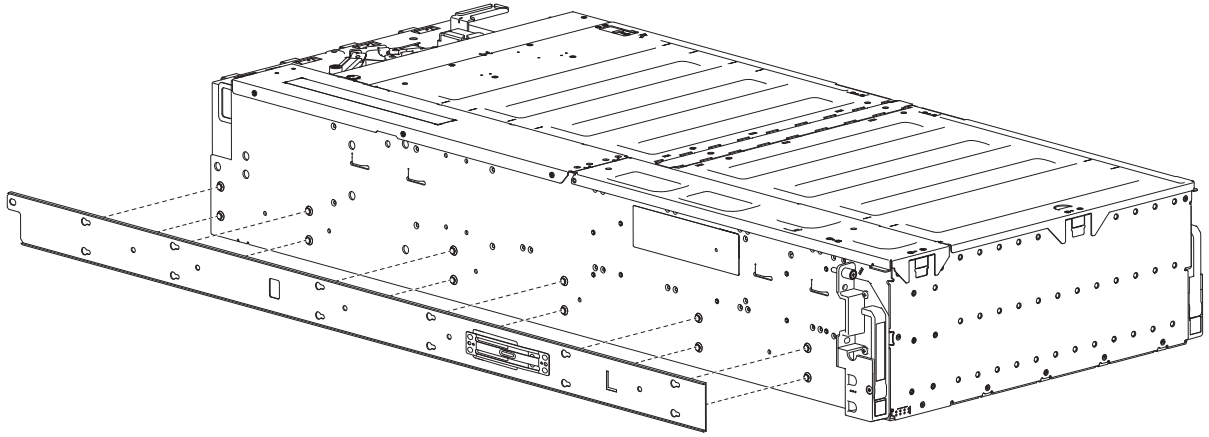

Figure 44 Left inner rail alignment

4. Slide the inner rail towards the rear until it locks against the T-pins and the screw holes align.

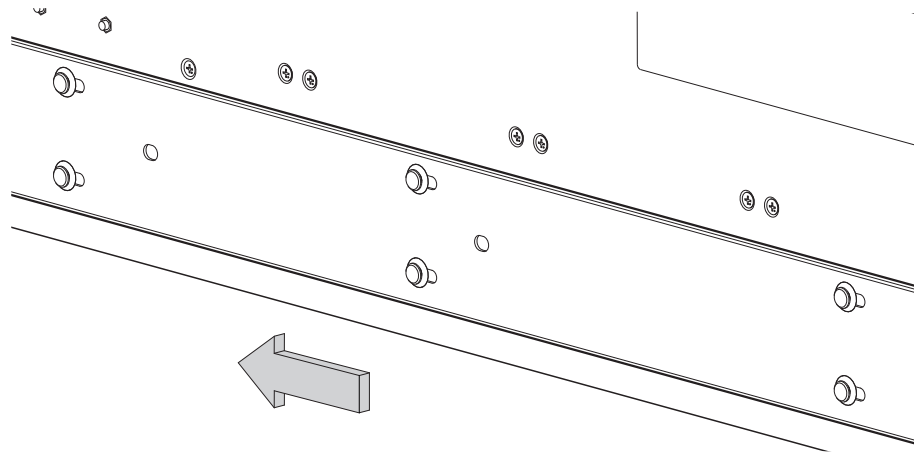

Figure 45 Lock T-pins and align screw holes

5. Secure the rail by inserting and tightening five M3 screws with the T10 Torx driver to a torque of 12 lbf-in (1.36 N-m).
6. Repeat the process for the right inner rail, using the proper orientation.
7. Locate the CMA A bracket in the CMA shipping box, then orient it so you can see the part number etched on it.
8. Facing the rear of the storage enclosure, locate the two holes on the right side of the chassis, above the CMA shelf.
9. Attach the CMA A bracket so that the face of the bracket is flush against the mounting flange of the chassis.
10. Insert and tighten the two (2) M4 panhead screws with a #2 Phillips-head screwdriver to a torque of 12 lbf-in (1.36 Nm).

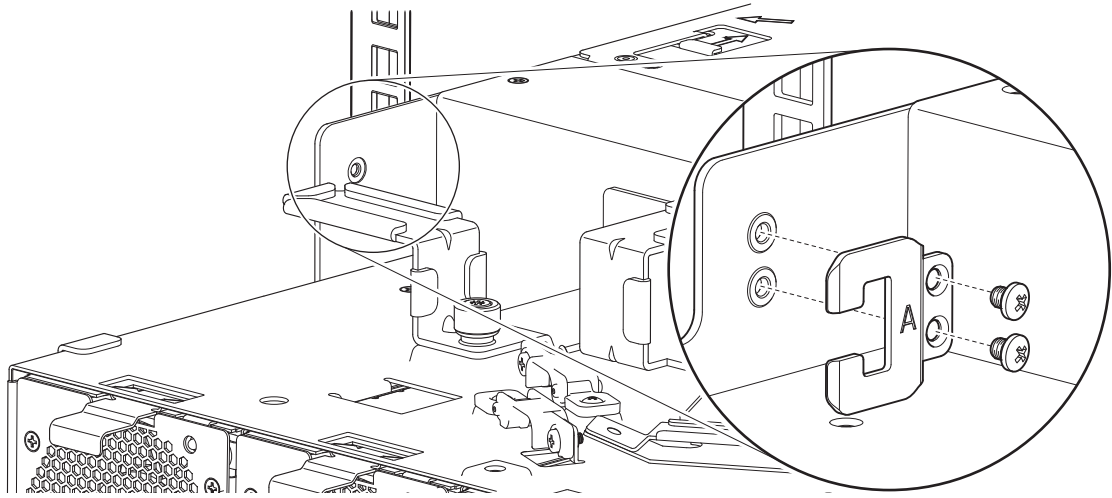

Figure 46 Attachment of the CMA A bracket

Installing the 4U100 enclosure

After you successfully complete the installation of the rack mount rail kit, you can mount the storage enclosure into the rack cabinet.

-
- ⚠ WARNING!** Do not attempt to install the storage enclosure into the rack cabinet with disk drives preloaded in the slots. Serious injury and damage could result. Unload any disk drives in storage enclosure slots to an ESD-protected area and track their location in the storage enclosure. You do not need to further lighten the storage enclosure by removing other components.
-

Mounting the storage enclosure into the rack cabinet

-
- ⚠ WARNING!** Serious injury and mechanical failure could result if you do not adhere to rack cabinet safety precautions.
- a. To avoid risk of death or injury from tipping the rack, follow all rack installation guidelines, securing the rack cabinet to the floor with a concrete anchor kit.
 - b. To avoid catastrophic failure of the rack assembly, never exceed rack cabinet weight limits.
 - c. Entirely support the storage enclosure with the mechanical lift until the storage enclosure is in the storage position.
 - d. Follow local occupational health and safety guidelines and meet all requirements for manual material handling.
-

Mounting the storage enclosure into the rack cabinet is the most critical of the installation procedures and requires your full attention. Safety and hardware longevity depend on the smooth function of the rails and correct implementation of this task. Key considerations include:

- Make sure there is sufficient clearance for the storage enclosure when fully extended in the service position and for a technician or system administrator.
- Observe rack cabinet weight limits.
- Fill the rack cabinet from the bottom to the top, mounting the heaviest equipment at the bottom.

- Make your approach to the rack cabinet with the lift level, straight, and parallel to the rack cabinet. Any skew, warp, or tilt will prevent the inner rails attached to the storage enclosure from properly engaging the outer and mid rails in the rack cabinet.

Required equipment	Quantity
Retractable tape measure	1
T25 Torx torque driver, 6-in. length	1
Mechanical lift	1
Storage enclosure with attached inner rails	1
Rack cabinet with installed outer and mid rails	1

To mount the storage enclosure into the rack cabinet:

1. Confirm that the rack rails are properly assembled, and that they are correctly and securely installed in the rack cabinet.
2. Confirm that the storage enclosure does not contain any disk drives.
3. Complete the following actions to position the lift and the storage enclosure:
 - a. Using proper safety precautions, position the storage enclosure on the mechanical lift perpendicular to the lift wheels.
 - b. Move the lift into position perpendicular to the rack cabinet so that the storage enclosure is parallel to the opening and is a minimum of 5 in. to 7 in. (12.7 cm to 17.78 cm) away from the rack cabinet.
 - c. Adjust the lift height to be as close as possible to the allocated 4U location.
 - d. Moving only the storage enclosure, position it so the attached inner rails align perfectly with the mid rails in the rack.

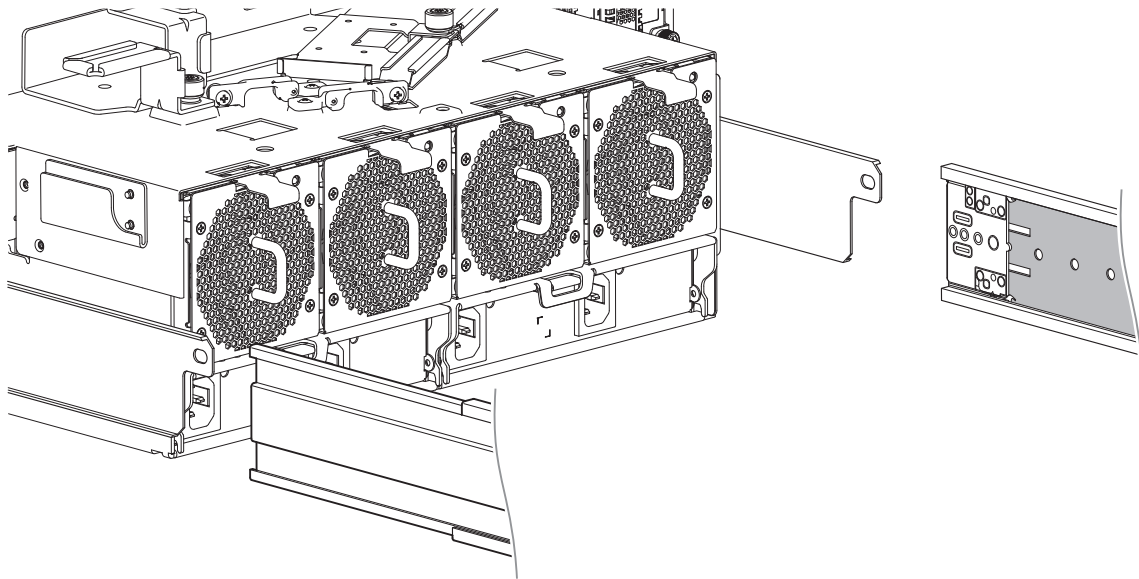

Figure 47 Align inner rails with mid and outer rails, detail

⚠ WARNING! Failure to properly seat the inner rail on the ball bearing retainers can cause immediate or gradual mechanical failure and can also cause integration failure. Serious injury could result.

4. Complete the following actions to prepare the rails to receive the storage enclosure:
 - a. Facing the cabinet, verify that both the top and bottom ball bearing retainers are fully seated.

- b. Slide both mid rail slides smoothly on the ball bearing retainers until they are fully forward and engage the inner leaf spring on the mid rail nearest the front mount bracket. Retention against the inner leaf spring is essential for proper rail sequencing and full engagement of the mid rail on the inner rail.

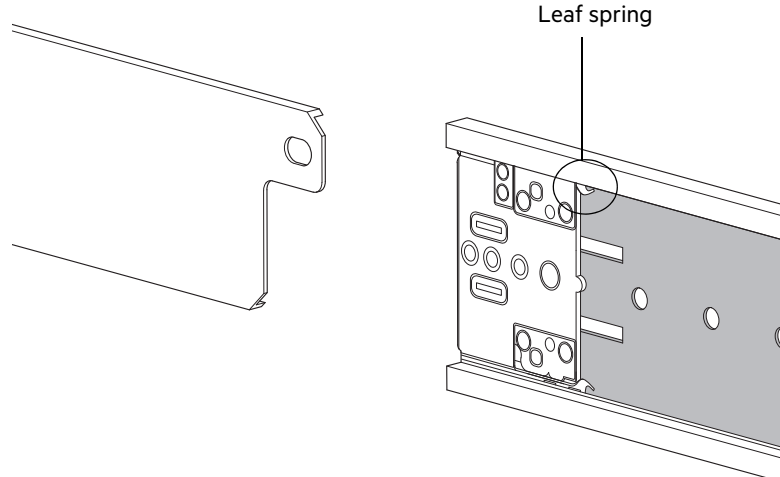

Figure 48 Leaf spring latch engaged, extension of mid rail to fully forward and locked position

- c. After releasing the safety lock on the outer rails, extend both left and right mid rails roughly 3 in. to 5 in. (7.62 cm to 12.7 cm) beyond the rack cabinet opening.
- d. Verify that both mid rails are the same distance from the rack cabinet face.

⚠ WARNING! To fine-tune any alignment adjustments, move only the storage enclosure or the mechanical lift. Do not move the mid rails or the rack cabinet.

- e. Fine-tune the alignment between the storage enclosure and that the rails, moving only the storage enclosure.
5. Complete the following actions to properly secure the storage enclosure on the rails:
 - a. a. Keep the storage enclosure stationary.
 - b. Verify that both rails are as far forward as possible and each engages the spring leaf at the very front of the rail.
 - c. Grasp the right ball bearing retainer, then continuously press it against the right mid rail to make sure it continues to engage the spring leaf at the very front of the mid rail.
 - d. Continuously maintain pressure on the ball bearing retainer as you slide the mid rail onto the inner rail, beginning with the top of the inner rail, then the bottom of the inner rail for the right side.
 - e. Continue maintaining pressure on ball bearing retainer while feeding the remainder of the mid rail onto the storage enclosure inner rail until reaching the maximum extension of the right rail.
 - f. Repeat for the left side.
 - g. Verify full engagement, top and bottom, of the inner rails with the top and bottom ball bearing retainers.
 - h. Verify the mid rails slide freely and smoothly on the inner rails. If they do not, this indicates misalignment and requires correction.
 - i. Slide both mid rails until they are fully extended in the service position and engage the safety lock.
 6. Complete the following actions to begin insertion of the storage enclosure into the rack cabinet:
 - a. Facing the front of the enclosure, carefully exert even pressure on both sides of the storage enclosure front, inserting the storage enclosure until it locks into the service position with an audible click.
 - b. Carefully and gently lower the mechanical lift just enough so that the weight of the storage enclosure fully rests on the rack rails.
 - c. Thoroughly examine the rack rails for issues such as bowing, scraping, resistance, or other indicators of misalignment.

- d. Locate and depress both safety lock latches to release the rails.

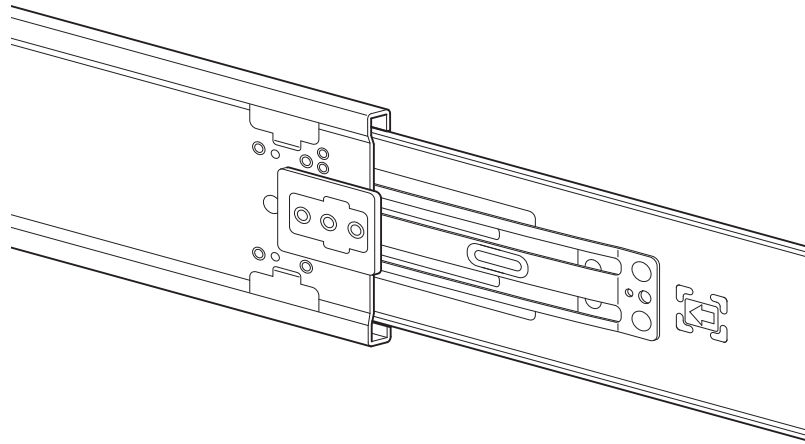

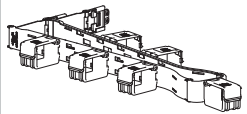

Figure 49 Release both safety lock latches

- e. Continue depressing the safety lock latch springs while inserting the storage enclosure into the rack just far enough to bypass the service position locks.
 - f. Carefully exert even pressure on both sides of the storage enclosure front.
 - g. Continue insertion all the way into the rack until the rack mounting flange is flush with the rack ears, locking the storage enclosure into the storage position. Do not force insertion, because this action could damage the rails.
7. Complete the following actions to confirm the proper installation of the storage enclosure into the rack cabinet:
 - a. Gently pull the storage enclosure outward to make sure the storage enclosure slides smoothly on its rails out to service position and returns smoothly to the storage position.
 - b. Feel for the smooth, even function of the ball bearings in the ball bearing retainer. Any grinding indicates misalignment and requires correction, up to obtaining a new rail kit if bearings are damaged.
 8. Secure the storage enclosure chassis flanges to the rack, fastening the top captive thumbscrew on each side with a T25 Torx torque driver until tight.

Installing the CMA and crossbar

The cable management arm (CMA) is an essential part of the storage enclosure as it holds data and power cables together securing efficient and effective storage enclosure connectivity. When properly attached, it extends itself when storage enclosure is pulled out of the rack into its service position and it retracts itself when the enclosure is pushed back into the rack.

The crossbar stabilizes the rear rails, keeps them parallel to each other, and protects them from inadvertent sideways forces that could damage their function.

Required equipment	Quantity	Identification
CMA assembly	1	
Crossbar	1	

To install the CMA assembly and crossbar:

1. Facing the rear of the rack cabinet, grasp the CMA assembly so that arrows by embossed letters point upwards and are visible to you, then fully extend it with the front end in your right hand.
2. Route the front end of the CMA C bracket in your right hand along the chassis guide bracket until it clips to the CMA A bracket you previously attached to the storage enclosure chassis.

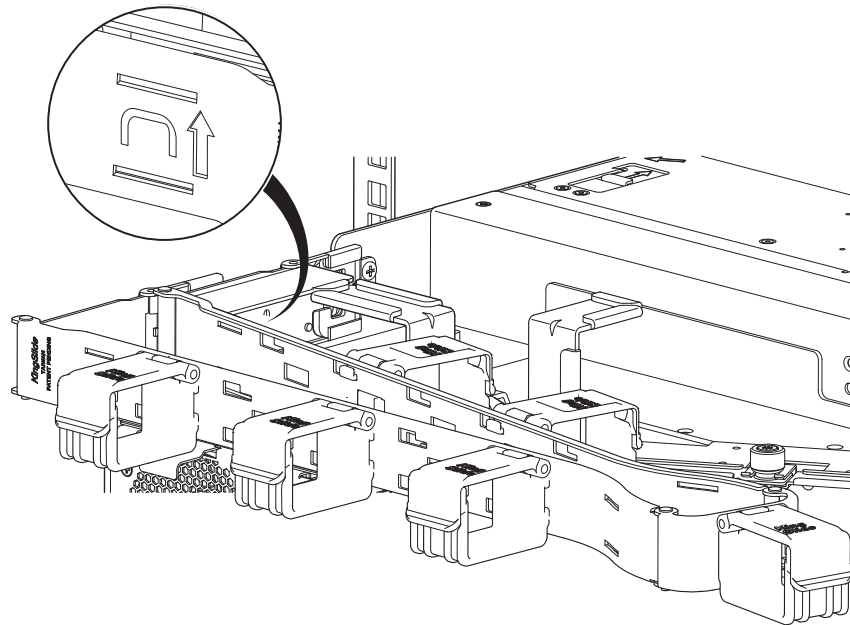

Figure 50 Attachment of the CMA C bracket assembly to the CMA A bracket on the chassis

3. Using the right hand you just freed, push the storage enclosure slightly forward to gain better access to the CMA B bracket.
4. Route the portion of the CMA D bracket in your left hand inward, until it clips to the CMA B bracket you previously installed on the outer rail.

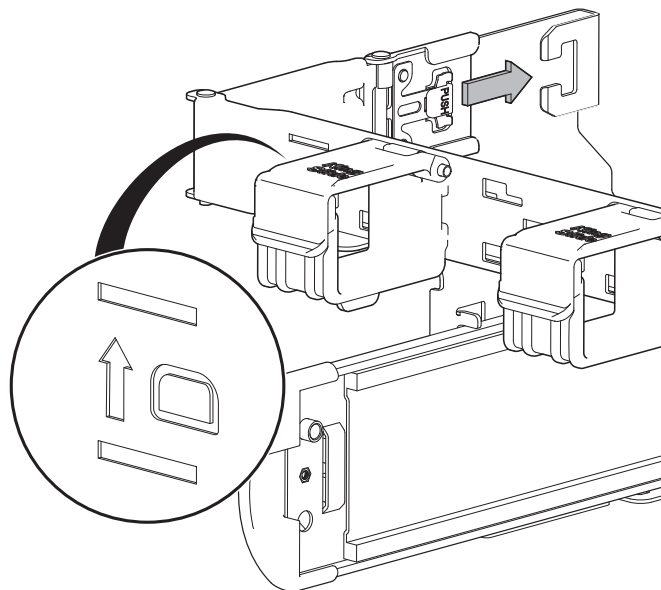

Figure 51 Insertion of CMA D bracket into CMA B bracket on the outer rail

5. Complete the following actions to verify the CMA assembly installation:

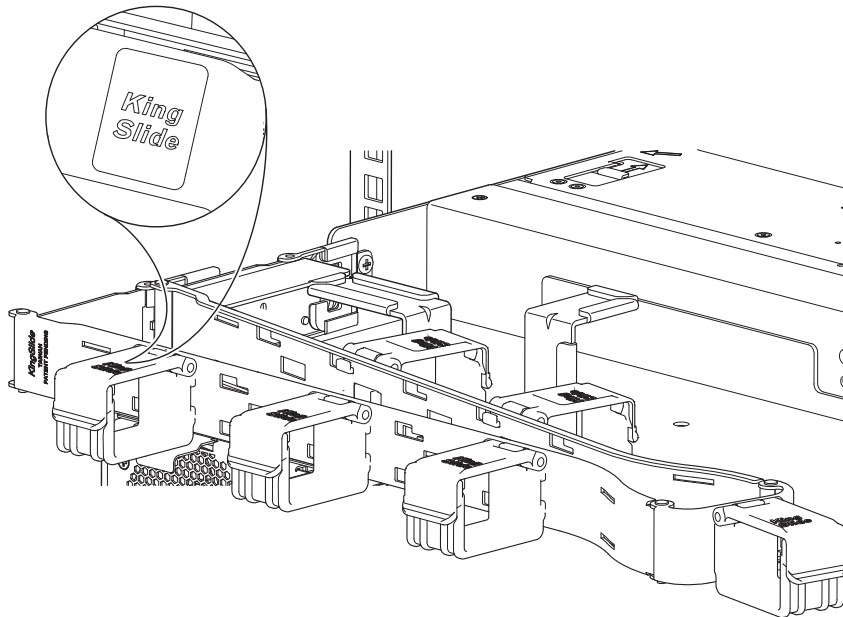

Figure 52 Proper installation of the CMA assembly

- a. Verify the blue spring of the CMA assembly securely clips to the CMA B bracket on the outer rail and that the other blue spring securely clips to the CMA A bracket.
 - b. Verify that all cable holders open upward and that you can read the embossed name King Slide when examining the top of each cable retainer.
 - c. After fully retracting the chassis, tug on the CMA to make sure you properly and securely installed it.
6. Install the crossbar by snapping each captive thumbscrew into the lower of the two available holes, twisting to the right to tighten them and stabilize the rails.

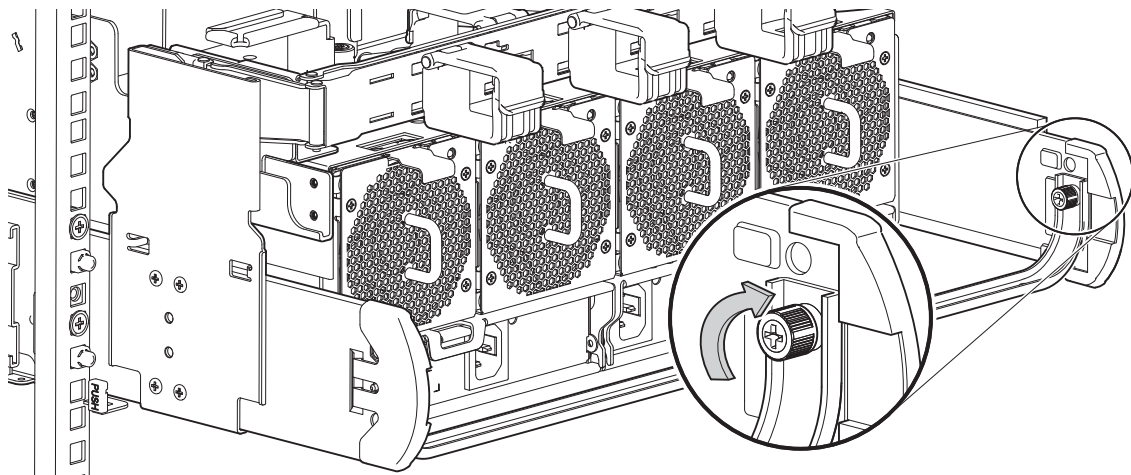

Figure 53 Direction to tighten crossbar thumbscrews

Installing drives

After installing the enclosure into the rack, you can proceed with the installation of the drives.

- ⓘ **IMPORTANT:** Check for free in and out movement of the enclosure into the rack to ensure secured installation of the enclosure.
Before installing the drives, refer to “[Populating drive slots](#)” (page 30), and “[ESD precautions](#)” (page 89).
-

To understand how to install a drive, see “[Installing a LFF drive carrier module](#)” (page 105). In order to run the enclosure smoothly, it is not necessary to fully-populate the drive slots (i.e. an enclosure with all 100 drives installed).

Routing cables using CMA

Routing of power and data cables for the 4U100 enclosure is integral to successful rail kit installation and rackmount installation of the enclosure. Cables must be correctly installed and routed to facilitate efficient operation and in-rack servicing of the enclosure.

4U100 is available in following 2 types of CMAs.

- Standard capacity CMA
- High capacity CMA

Selection of either of above CMA depends upon customer requirement.

Routing cables through the Standard CMA

- ⓘ **IMPORTANT:** This section provides instructions for routing cables through the Standard capacity and High capacity CMA configuration, which include using the CMA baskets and the CMA storage shelf located at the rear of the enclosure.

Depending on your 4U100 enclosure configuration, power cables are routed either using an open lever and hinge brackets (butterfly) mechanism or they are routed through two cable clamps. Photographs in this section shows CMA shelf equipped with an open lever which holds power cables coming from left PSU.

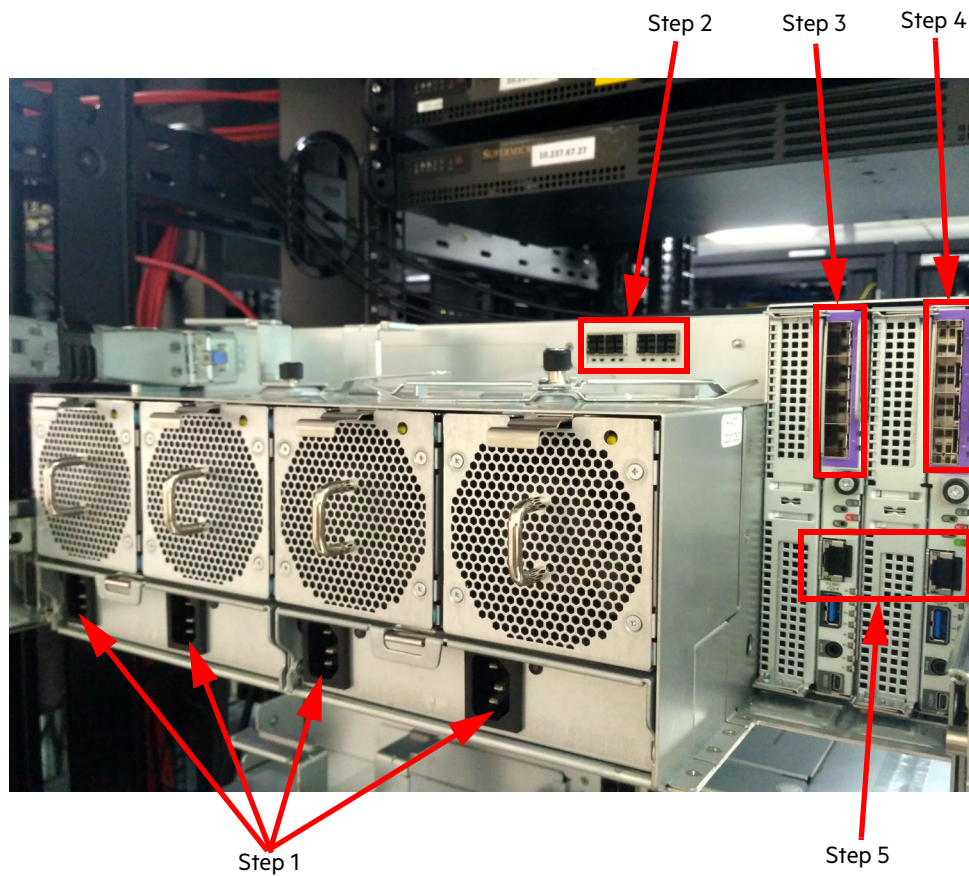

Figure 54 Cable routing sequence using Standard capacity CMA

1. Install the power cables and route them through the CMA brackets.
 - o Route left two power cables through open lever.
 - o Route right two power cables through left hinge system.

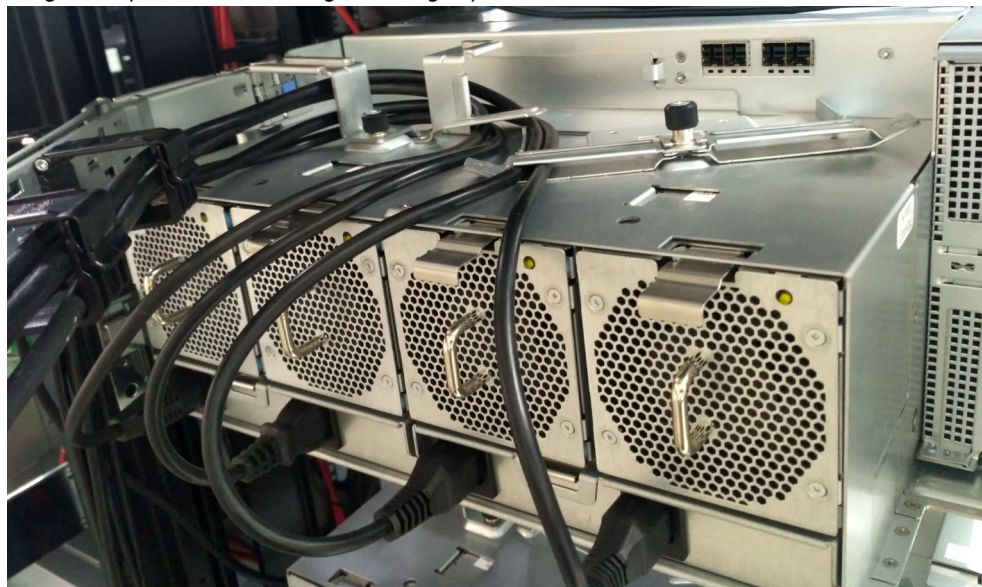

Figure 55 Routing PSU cables

2. Route Ethernet cables of the both Controller modules through hinge brackets.

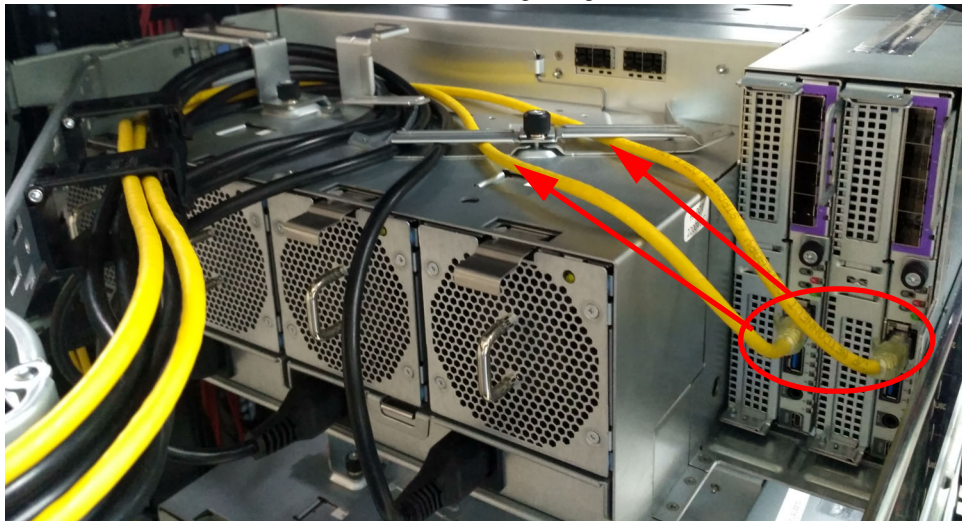

Figure 56 SAS cables routing

3. Install left controller's 10GbE SFP+ cables (4 ports) and route them through the right hinge system and then through the CMA brackets.



Figure 57 Routing 10GbE SFP+ cables of the left controller

4. Install right controller's 10GbE SFP+ cables (4 ports) and route them through the left hinge system and then through the CMA brackets.



Figure 58 Routing 10GbE SFP+ cables of the right controller

5. Install a SAS cable between the mini-SAS expansion port 0 on the Exos AP 4U100 and the right IOM of the expanded JBOD. Similarly, Install a SAS cable between the mini-SAS expansion port 1 and the left IOM of the expanded JBOD, and route both these cables through the CMA brackets.
6. Follow above [step 5](#) to connect SAS expansion port 2 and 3 to an IOM pair of another JBOD.

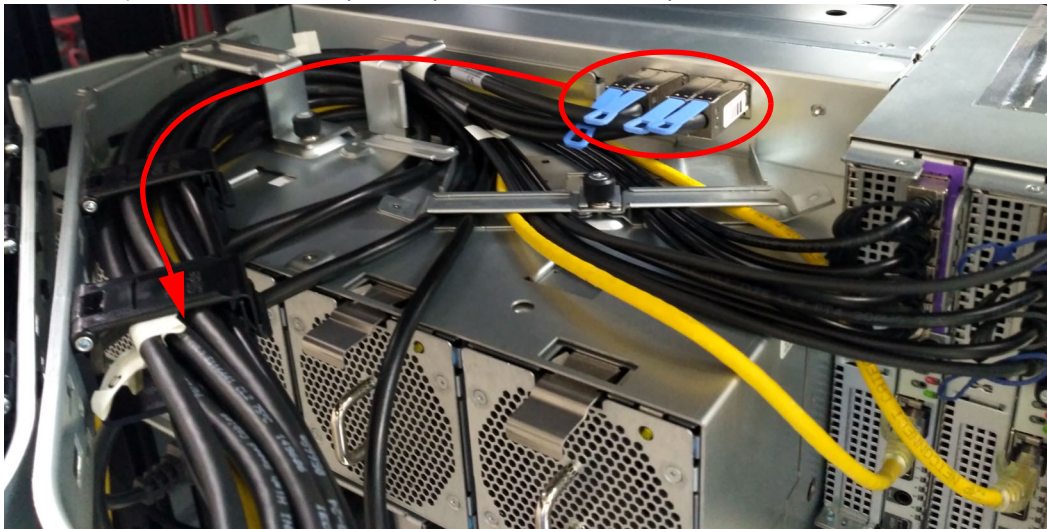

Figure 59 Routing SAS cables

-
- ① **IMPORTANT:** After routing the cables, pull out the enclosure to fully extend it, and check for free movement of the CMA along with cables. Make sure that there is no stress on any cable or on CMA parts.
-

Routing cables through the High capacity CMA

ⓘ **IMPORTANT:** This section provides instructions for routing cables through the High capacity CMA configuration, to include using the CMA baskets and the CMA storage shelf located at the rear of the enclosure.

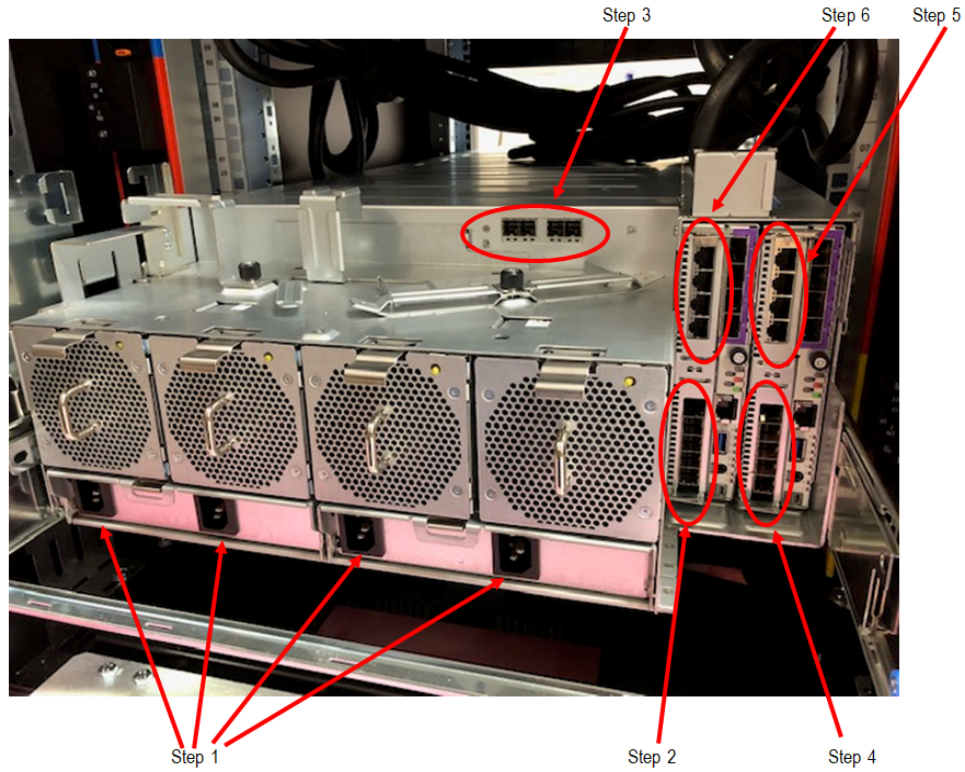

Figure 60 Cable routing sequence using High capacity CMA

1. Install the power cables and route them through the CMA brackets.
 - o Route left two power cables through lever.
 - o Route right two power cables through left hinge system.

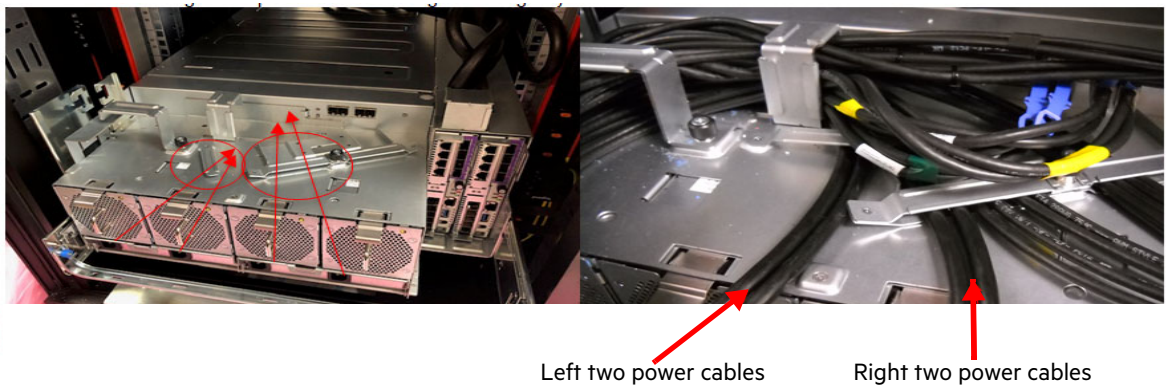

Figure 61 Power cable routing (enclosure with High capacity CMA brackets)

2. Install left controller SAS cables (4 ports) and route them through the CMA brackets.
 - o Route bottom two SAS cables through left side of hinge system.
 - o Route top two SAS cables through right side of hinge system.
 - o Keep cables as flat as possible and keep out of fan exhaust.

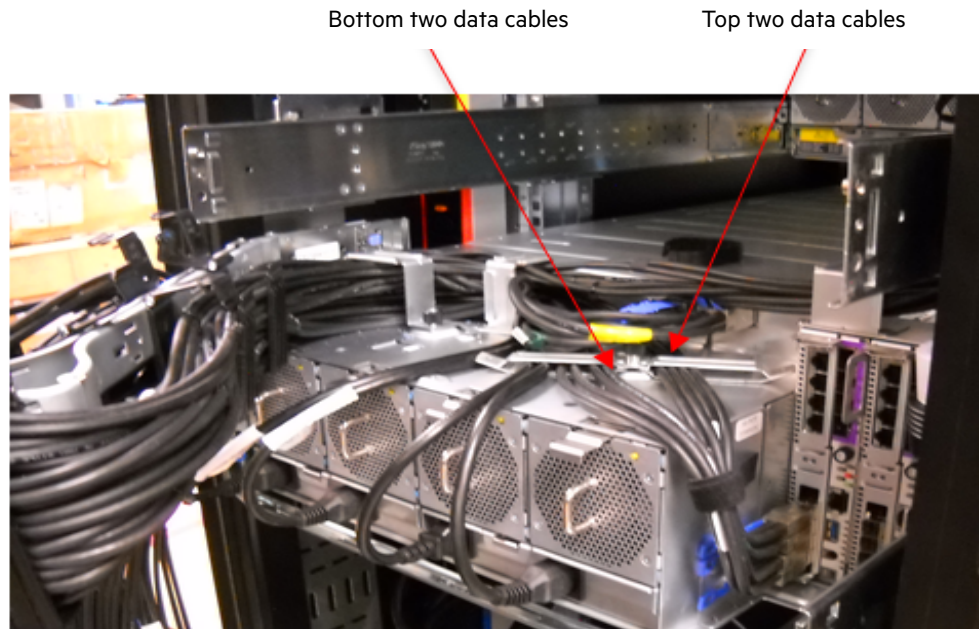

Figure 62 Routing data cables (enclosure with High capacity CMA brackets)

3. Install top SAS cables (4 ports) and route them through the CMA brackets.

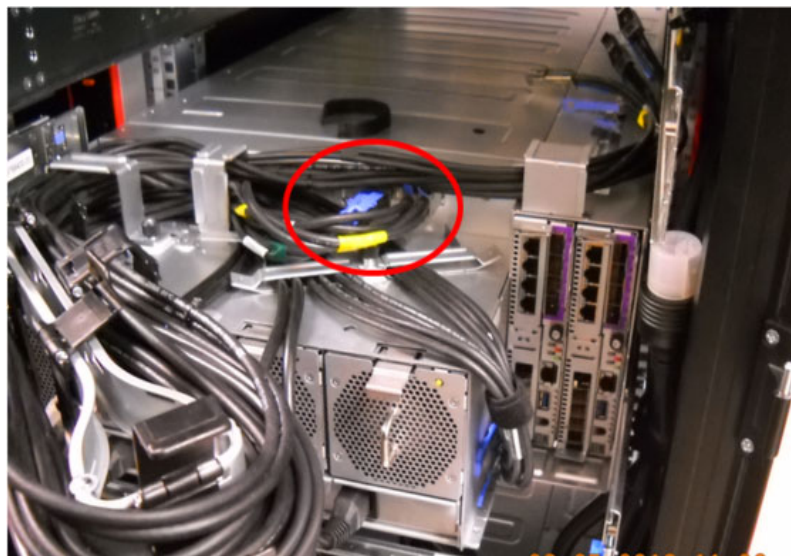

Figure 63 Routing top 4 SAS cables

4. Install right controller SAS cables (4 ports) and route them through the CMA brackets.
 - o Route SAS cables through top bracket

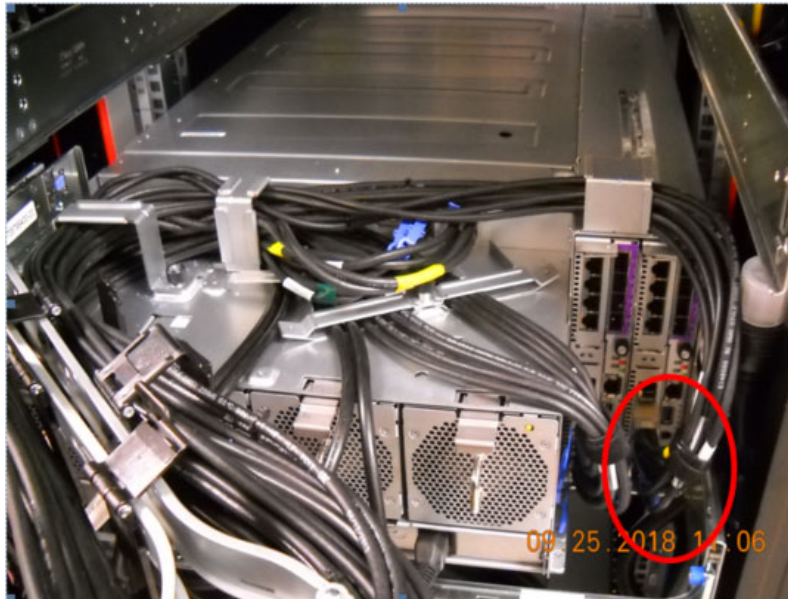

Figure 64 Routing right controller SAS cables

5. Install right controller Ethernet cables (4 ports) and route them through the CMA brackets.
 - o Route Ethernet cables through top bracket

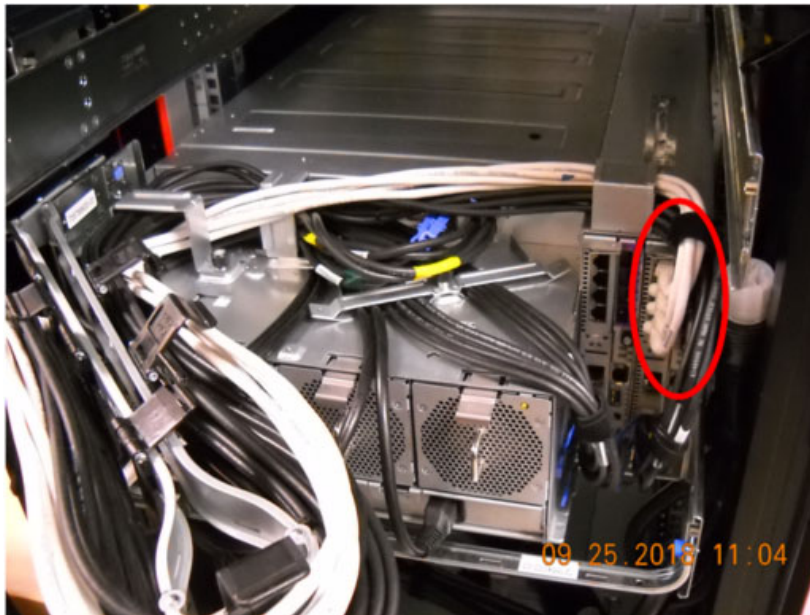

Figure 65 Routing right controller Ethernet cables

6. Install left controller Ethernet cables (4 ports) and route them through the CMA brackets.
 - o Route Ethernet cables through right hinge. Make sure cables are flat.

-
- ① **IMPORTANT:** After routing the cables, pull out the enclosure to fully extend it, and check for free movement of the CMA along with cables. Make sure that there is no strain on any cable.
-

Cable requirements for expansion enclosures

When adding storage, use only Seagate or OEM-qualified cables, and observe the following guidelines:

- When attaching expansion enclosures, use only supported HD mini-SAS (SFF-8644) x4 cables.
- Qualified HD mini-SAS cables, not to exceed 5 m (16.40'), are used to connect cascaded enclosures in the rack.
- The maximum expansion cable length allowed in any configuration is 5 m (16.40').
- When adding more than two expansion enclosures, you may need to purchase additional cables, depending upon number of enclosures and cabling method used.
- You may need to order additional or longer cables when cabling a fault-tolerant configuration.

SAS topology

It is possible to support different topologies of SAS with the 4U100 enclosure. There are two basic forms of expansion topology: one is a simple Daisy Chain where enclosures are connected one after another in a chain as shown in [Figure 66 \(page 77\)](#). The other topology is a Star configuration where each expansion enclosure is connected to the 4U100 enclosure as shown in [Figure 67 \(page 78\)](#).

SAS cabling methods

As you face the rear panel of the Exos AP 4U100, the left Controller module slot is 1 and the right Controller module slot is 0. See [Figure 5 \(page 24\)](#) for CRU slot index numbering for the enclosure rear panel.

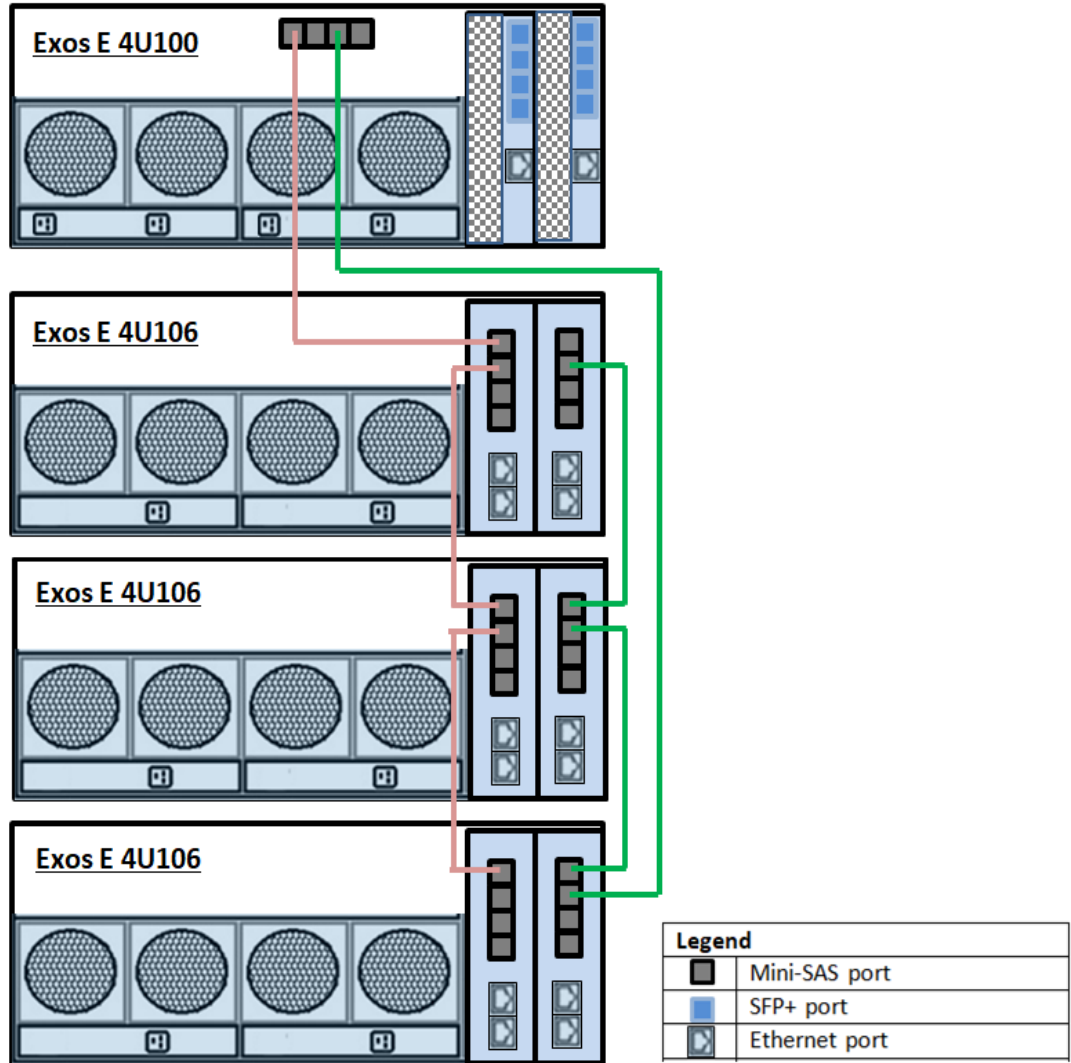

Figure 66 Connecting 4U100 enclosure to 4U106 enclosures using Daisy Chain configuration

Above [Figure 66](#) shows the Daisy Chain cabling method and the [Figure 67 \(page 78\)](#) shows the Star cabling method.

An advantage of the Star configuration is that each expansion enclosure is only one additional expander or “hop” away from the initiator. This reduces delays in the SAS communication path. Those effects are small by measure. However, there are a limited number of expansion ports, so for larger topologies, some combination of the two approaches will be required.

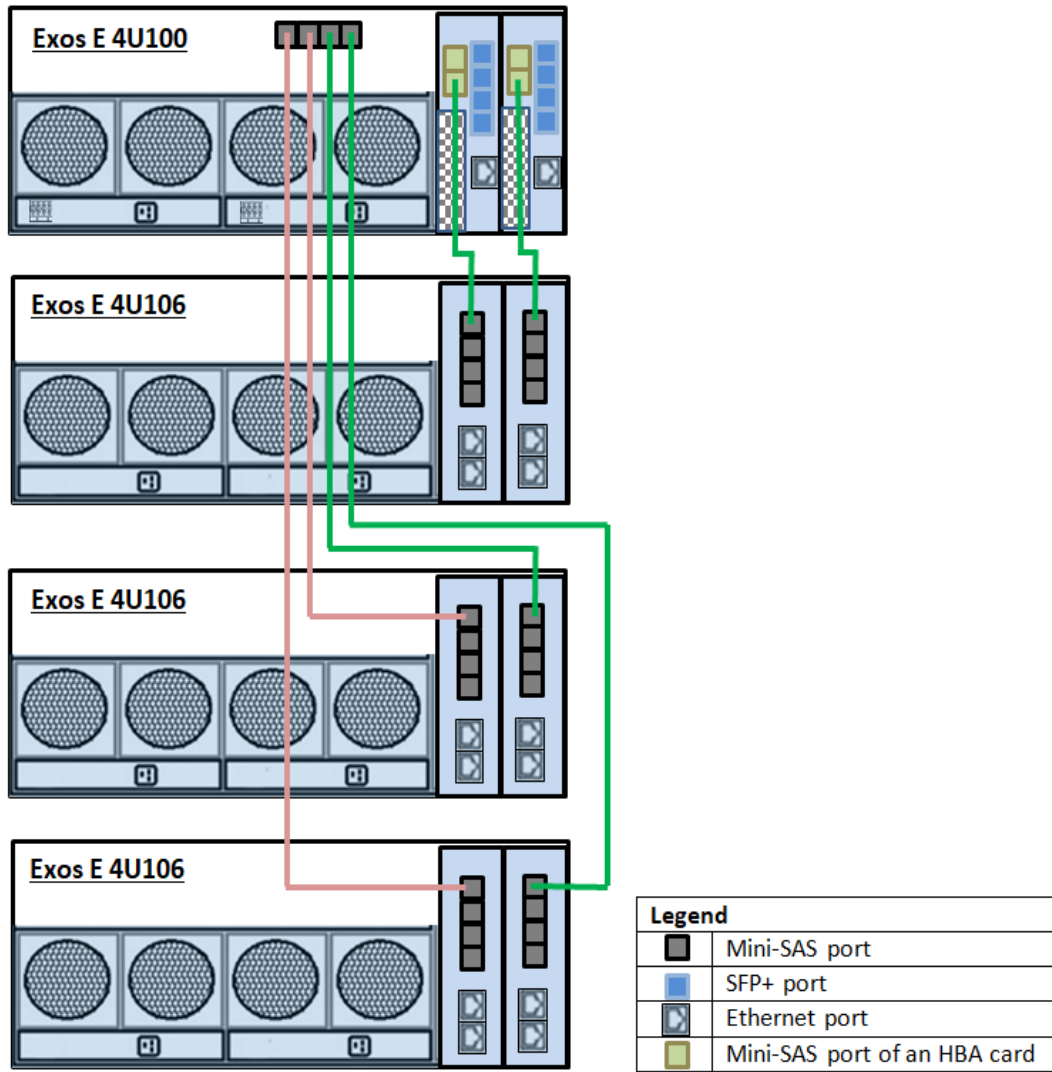

Figure 67 Connecting 4U100 enclosure to 4U106 enclosures using Star Configuration

Power cord connection

Connect a power cord from each PSU on the enclosure rear panel to the PDU (power distribution unit) as shown in the illustration below.

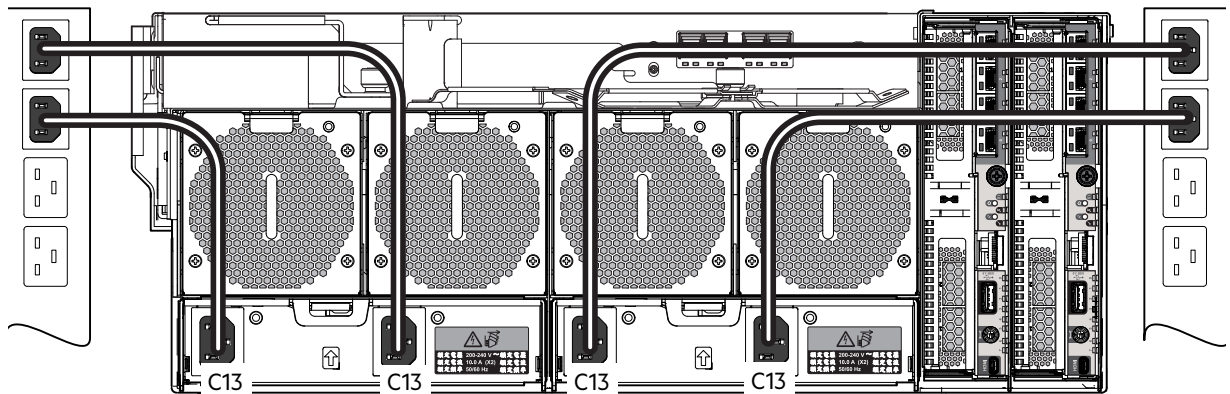

Figure 68 Typical AC power cord connection from PDU to PSU

-
- ⓘ **IMPORTANT:** The 4U100 enclosure is fitted with two redundant PSUs. All power cords must be connected to at least two separate and independent power supplies to ensure redundancy.
- [Figure 68 \(page 79\)](#) shows power connection from a dual-core PSU to a PDU using C13 cable connectors connected to the C14 receptacles on the PSUs.
 - The connector of the other end of the AC cable will be dependent upon the PDU.
-

- ⚠ **CAUTION:** Power connection concerns:
- Never connect the power cord to the PSU before installing the PSU in the system.
 - Always remove the power connections *before* you remove the PSU from the enclosure.
 - Whether using standard (single-lead) or bifurcated (Y-lead), power cords must only be connected to a supply range of 200–240V AC as indicated on each PSU's hazardous voltage warning label.
 - Make sure the power cords are not caught on the stabilizer bar before sliding the rack out of the enclosure on its rails. If a power cord is caught on the stabilizer bar, then the power cord connector may pull out of the PSU socket as the enclosure slides out of the rack.
-

Testing enclosure connections

See “[Powering ON/powering OFF](#)” (page 80). Once the power-on sequence succeeds, the storage system is ready to be connected.

Grounding checks

The product must only be connected to a power source that has a safety electrical earth ground connection.

-
- ⚠ **CAUTION:** If more than one enclosure goes in a rack, the importance of the earth ground connection to the rack increases because the rack will have a larger Earth Leakage Current (Touch Current).
-

Examine the earth ground connection to the rack before power on. An electrical engineer who is qualified to the appropriate local and national standards must do the examination.

4 Operation

Before you begin

Before powering ON the enclosure system, make sure that all modules are firmly seated in their correct slots. Verify that you have successfully completed the sequential “Installation Checklist” instructions in [Table 4 \(page 45\)](#). Once you have completed these steps, you can access the management interfaces to complete the system setup.

Powering ON/powering OFF

⚠ CAUTION: Do not operate the enclosure system until the ambient temperature is within the specified operating range described in [“Environmental requirements” \(page 113\)](#). If the drive modules have been recently installed, make sure they have had time to adjust to the environmental conditions before they are used with production data for I/O.

- Power ON the enclosure by connecting the power cables from the PSU to the PDU. See [Figure 68 \(page 79\)](#). The System Power LED on the front panel should be lit green when the enclosure power is activated.
- Power OFF the system by disconnecting the power cord from the power supply module.

When powering ON, make sure to power up the enclosures and associated data host in the following order:

1. Expansion enclosures (Exos E 4U106) *first*

This ensures that the disks in the expansion enclosures have enough time to completely spin up before being scanned by the Controller modules within the server enclosure (Exos AP 4U100).

While enclosures are getting powered ON, their LEDs blink. After the LEDs stop blinking—if no LEDs on the front, back and top of the enclosure are amber—the power ON sequence is complete, and no faults have been detected.

- a. See [“Overview of front panel LEDs”](#) and [Figure 15 on page 32](#).
- b. See [“Overview of rear panel LEDs” \(page 33\)](#) and figures/tables for rear panel CRUs.
- c. See [“Overview of top LEDs” \(page 38\)](#) and figures/tables for top panel CRUs.

2. Controller enclosure *next*.

Depending upon the number and type of disks in the system, it may take several minutes for the system to become ready.

Depending upon system configuration, when power is applied to the 4U100 enclosure, the Controller modules will either boot to standby or move to full operation. To transit from standby to operation, you can use “Reset” button or use IPMI. For more information consult with your Integration partner.

3. Data host *last* (if powered OFF for maintenance purposes).

When powering OFF, you will reverse the order of steps used for powering ON.

ⓘ IMPORTANT: If main power is lost for any reason, upon restoration of power, the system will restart automatically.

NOTE: Refer [“Front panel LEDs” \(page 82\)](#) for details pertaining to front panel LEDs and related fault conditions.

5 Troubleshooting and problem solving

These procedures are intended to be used only during initial configuration, for the purpose of verifying that hardware setup is successful. They are not intended to be used as troubleshooting procedures for configured systems using production data and I/O.

NOTE: For further troubleshooting help—after setup and when data is present—see <https://seagate.com/support-home>.

Overview

The enclosure system includes a Storage Enclosure Processor (SEP) and associated monitoring and control logic to enable it to diagnose problems with the enclosure’s power, cooling, and drive systems. Management interfaces allow for provisioning, monitoring, and managing the storage system.

❗ **IMPORTANT:** See “[Fault isolation methodology](#)” (page 85) when conducting system diagnostics.

Initial start-up problems

Faulty power cords

Check that you have correctly cabled the system. Contact your supplier for replacements if:

- Power cables are missing or damaged.
- Plugs are incorrect.
- Power cables are too short.

LEDs

LED colors are used consistently throughout the enclosure and its components for indicating status:

- Green: good or positive indication
- Blinking green/amber: non-critical condition
- Amber: critical fault
- Blue: identification

PSU LEDs

Under normal conditions, the bitonal PSU Status OK LED will be a constant green. See [Figure 16](#) (page 34). When a fault occurs, the color of the LEDs will be displayed as shown in the following table.

Table 6 PSU LED states

PSU Status (green)	PSU Status (amber)	Status
OFF	OFF	No AC power on this PSU
ON	OFF	AC power ON; PSU working correctly
OFF	ON	PSU fault (over temperature, over voltage, over current) or PSU AC power is low

Table 6 PSU LED states

PSU Status (green)	PSU Status (amber)	Status
OFF	Blinking	Ident bit is getting set
Blinking	OFF	PSU firmware download is in progress

Front panel LEDs

The front panel displays the aggregated status of all the modules. The enclosure status LEDs located on the front panel are labeled in [Figure 15 \(page 32\)](#) and they are individually described in the narrative subsections that follow the table.

Drive module LEDs

Drive status is indicated by an amber LED mounted on the front of each drive carrier module, as shown in [Figure 69](#). The drive module LED conditions are defined in the table following the figure.

- In normal operation the blue LED will be OFF, and will flicker as the drive operates.
- In normal operation the amber LED will be:
 - OFF if there is no drive present.
 - OFF as the drive operates.
 - ON if there is a drive fault.
 - Blinking if the SES device identity is set.

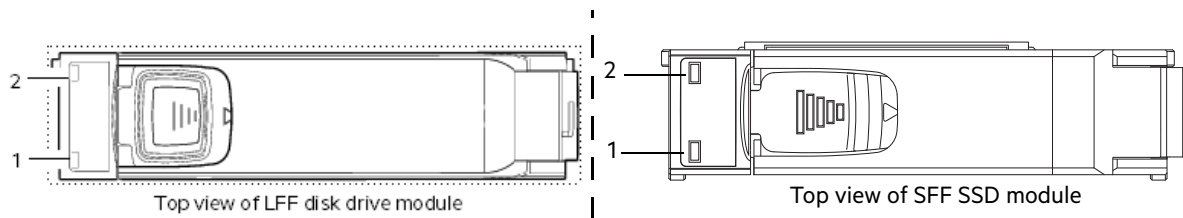

Disk LED 1	Disk LED 2 (amber)	Status
	OFF	Enclosure is not powered ON.
	OFF	Drive module is installed and operational
Always OFF	Blinking: 1s ON/1s OFF	SES device identity set
	ON	SES device fault bit set
	ON	Fault in the drive

Figure 69 LEDs: LFF/SFF Drive carrier LEDs

Expansion port LEDs

Each Exos AP 4U100 enclosure has four expansion ports located at the back top of the chassis, above the CMA as shown in [Figure 9 \(page 26\)](#). Expansion port status is indicated by two LEDs below each port. Apart from this, a successful expansion link connection is indicated by Port Status LED. It lits green once a successful expansion link is connected. See [Figure 19 \(page 37\)](#).

LED behaviors for expansion enclosures are described in [Table 7](#).

Table 7 Expansion port LED status

Expansion (green)	Expansion (amber)	Description
OFF	OFF	Enclosure is OFF, or no expansion cable is plugged in
ON	OFF	Normal operation
ON	ON	SAS port/cable has a fault
Blinking	OFF	SES device Ident function

For actions pertaining to [Table 7](#), see the **Actions** below.

Actions:

- If both LEDs are OFF: Make sure that SAS cable is securely connected to the expansion port. If it is, then make sure that both server enclosure (Exos AP 4U100) and expansion enclosure (Exos E 4U106 or any other EBOD) are powered ON.
- If both LEDs are ON:
 - Make sure that SAS cable is connected securely.
 - If it is, then this indicates the respective SAS cable to be faulty.
- If the above actions do not resolve the fault, contact your supplier for assistance.

Temperature sensors

Temperature sensors throughout the enclosure and its components monitor the thermal health of the storage system. Exceeding the limits of critical values will cause a notification to occur.

Troubleshooting

The following sections describe common problems that can occur with your enclosure system, and some possible solutions. For the problems listed in [Table 8](#), the respective module fault LEDs on the enclosure front panel will light amber to indicate a fault. See [“Overview of front panel LEDs” \(page 32\)](#).

Table 8 Alarm conditions

Status	Severity	Alarm
PSU alert - loss of DC power from a single PSU	Fault - loss of redundancy	S1 ¹
Fan module failure	Fault - loss of redundancy	S1 ¹
CFF module detected PSU fault	Fault	S1 ¹
PSU removed	Configuration error	None ²
Enclosure configuration error (VPD)	Fault – critical	S1 ¹
Low warning temperature alert	Warning	S1 ¹
High warning temperature alert	Warning	S1 ¹
Over temperature alarm	Fault – critical	S4 ³
I ² C bus failure	Fault – loss of redundancy	S1 ¹

Table 8 Alarm conditions (continued)

Status	Severity	Alarm
Front panel communication error (I ² C)	Critical fault	S1 ¹
RAID error	Fault – critical	S1 ¹
CFF interface module fault	Fault – critical	S1 ¹
CFF interface module removed	Warning	None ²
Drive power control fault	Fault – critical–loss of disk power	S1 ¹
Insufficient power available	Warning	None ²

1-The enclosure will continue operating, requiring an administrator to take an appropriate action; such as replacing a PSU or reducing the room temperature. Alarm messages are signaled by the SES pages. Refer GEM5 ANSI SES-3 Specification document for more information.

2-An alarm is not issued for this status and severity condition.

3-The enclosure will take action; such as shutting down in order to protect the enclosure's data content. Alarm messages are signaled by the SES pages. Refer GEM5 ANSI SES-3 Specification document for more information.

PSU and system fan faults

Symptom	Cause	Recommended action
Front panel Module Fault LED is amber ¹	Any power fault	Verify AC mains connections to the PSU are live
Amber LED is illuminated on system fan module ²	Fan failure	Replace system fan module

1-See [Figure 15 \(page 32\)](#) for visual reference of front panel LEDs.

2-See [Figure 16 \(page 34\)](#) for visual reference of PSU LEDs. See [Figure 17 \(page 35\)](#) visual reference of system fan module LEDs.

Thermal monitoring and control

The storage enclosure system uses extensive thermal monitoring and takes a number of actions to ensure component temperatures are kept low, and to also minimize acoustic noise. Air flow is from the front to back of the enclosure.

Symptom	Cause	Recommended action
<p>If the ambient air is below 25°C (77°F), and the fans are observed to increase in speed, then some restriction on airflow may be causing additional internal temperature rise.</p> <hr/> <p>NOTE: This is not a fault condition.</p>	<p>The first stage in the thermal control process is for the fans to automatically increase in speed when a thermal threshold is reached. This may be caused by higher ambient temperatures in the local environment, and may be perfectly normal.</p> <hr/> <p>NOTE: This threshold changes according to the number of disks and power supplies fitted.</p>	<ol style="list-style-type: none"> 1. Check the installation for any airflow restrictions at either the front or back of the enclosure. A minimum gap of 25 mm (1") at the front and 50 mm (2") at the rear is recommended. 2. Check for restrictions due to dust build-up. Clean as appropriate. 3. Check for excessive re-circulation of heated air from rear to front. Use of the enclosure in a fully enclosed rack is not recommended. 4. Verify that all blank modules are in place. 5. Reduce the ambient temperature.

Thermal alarm

Symptom	Cause	Recommended action
1. Front panel Module Fault LED is amber.	Internal temperature exceeds a preset threshold for the enclosure.	<ol style="list-style-type: none">1. Verify that the local ambient environment temperature is within the acceptable range. See Note on page 113.2. Check the installation for any airflow restrictions at either the front or back of the enclosure. A minimum gap of 25 mm (1") at the front and 50 mm (2") at the rear is recommended.3. Check for restrictions due to dust build-up. Clean as appropriate.4. Check for excessive re-circulation of heated air from rear to front. Use of the enclosure in a fully enclosed rack is not recommended.5. If possible, shut down the enclosure and investigate the problem before continuing.

Fault isolation methodology

This section presents the basic methodology used to locate faults within a storage system, and to identify the pertinent CRUs affected.

Basic steps

- Gather fault information, which includes use of system LEDs.
- Determine where in the system the fault is occurring.
- Review logs from the operating system.
- Review ddump output from both controllers:
 - The ddump CLI command is described in the GEM Command-line Interface document.
 - ddump can be captured via the following interfaces: serial, Telnet, WCLI/SES.
 - Invoke `help ddump` for additional information about capturing ddump output.See also "[GEM Command-line interface \(CLI\)](#)" ([page 44](#)).
- If required, isolate the fault to a data path component or configuration as described in "[Isolate the fault](#)" ([page 86](#)).

Gather fault information

When a fault occurs, it is important to gather as much information as possible. Doing so will help you determine the correct action needed to rectify the fault.

Begin by reviewing the reported fault:

- *Is the fault related to an internal data path or an external data path?*
- *Is the fault related to a hardware component such as a drive module, controller module, or power supply unit?*

Determine where the fault is occurring

When a fault occurs, the Module Fault LED—located in the lower left corner of the enclosure front panel—illuminates. See [“Overview of front panel LEDs” \(page 32\)](#). Check the status of the other front panel LEDs. Also check the LEDs on the back and top (must remove a lid) of the enclosure to narrow the fault to a CRU, connection, or both.

- See [“Overview of rear panel LEDs” \(page 33\)](#)
- See [“Overview of top LEDs” \(page 38\)](#)

The LEDs help you identify the location of a CRU reporting a fault.

Isolate the fault

Occasionally, it might become necessary to isolate a fault. This is particularly true with data paths, due to the number of components comprising the data path. For example, if a host-side data error occurs, it could be caused by any of the components in the data path: controller module, cable, or data host. By isolating the fault to *one* of the components within the storage system, you will be able to determine the necessary corrective action more quickly.

If the enclosure does not initialize

It may take up to two minutes for all enclosures to initialize. If an enclosure does not initialize:

- Power cycle the system
- Make sure the power cord is properly connected, and check the power source to which it is connected
- Check log for errors

Host I/O

When troubleshooting drive and connectivity faults, stop I/O to the affected drive groups from all hosts as a data protection precaution. As an additional data protection precaution, it is helpful to conduct regularly scheduled backups of your data. See [“Stopping I/O” \(page 107\)](#).

Dealing with hardware faults

Ensure that you have obtained a replacement module of the same type before removing any faulty module as described in [“Module removal and replacement” \(page 89\)](#).

❗ **IMPORTANT:** If the enclosure system is powered up and you remove any module, replace it immediately. If the system is used with any modules missing for more than a few seconds, the enclosure(s) can overheat, causing power failure and potential data loss. Such action can invalidate the product warranty.

❗ **IMPORTANT:** Observe applicable/conventional ESD precautions when handling modules and components, as described in [“ESD precautions” \(page 89\)](#). Avoid contact with midplane components, module connectors, leads, pins, and exposed circuitry.

Continuous operation during replacement

Your hardware or software enclosure management application determines the capability for replacing a failed disk without the loss of access to any file system on the enclosure. Enclosure access and use during this period is uninterrupted. If an enclosure is equipped with redundant PSUs, sufficient power is provided to the system while the faulty module is replaced.

NOTE: Exos AP 4U100 enclosures support hot-plug replacement of redundant controller modules, power supplies, fan modules, and HS expanders. Hot-add replacement of expansion enclosures is also supported.

Firmware updates

After installing the hardware and powering ON the storage system components for the first time, verify that the controller modules, expansion modules, and drives are using the current firmware release. Periodically, you should ensure that the firmware versions used in enclosure modules are compatible. Product Release Notes describe the process for updating firmware. Contact your system engineer or raise a ticket in the Support portal for additional information.

Customer-replaceable units (CRUs)

CRUs addressing 4U100 chassis

Table 9 Exos AP 4U100 product components

Item	Enclosure CRU and related component description	Access ¹
1	Drive (LFF/SFF) module:	Top
	a) DDIC 3.5" LFF (drives of differing type, SAS or SATA interface, and capacity)	
	b) DDIC 2.5" SFF (disks of differing type, SAS or SATA interface, and storage capacity)	
2	Chassis (sheet metal enclosure) with integrated PCBAs (baseplanes included with chassis; not available separately)	Note 2
3	Power supply unit (PSU) module available as AC unit (chassis uses two PSUs of same model type)	Rear
4	Controller module to provide server capability to the enclosure	Rear
5	System fan module	Rear
6	Controller fan module	Top
7	HS Expander module (PCBA card)	Top
8	Rail kit (variable attachment options)	Note 3
	a) Rack mount kit, shelf, long (1.2 m), HW	
	b) Cable Management Arm (CMA) and brackets	
9	Cable kits [Cable package: standard HD mini-SAS (SFF-8644) to HD mini-SAS (SFF-8644)]	N/A
10	AC power cord compatible with AC PSU	N/A

1-The **Access** column lists the enclosure panel from which the CRU is observed and accessed. It does not apply to other components.

2-See "Enclosure chassis" (page 31) for a description of the chassis CRU.

3-See "Preparing for installation" (page 46) and "Installing the 4U100 enclosure" (page 63) for descriptions of the rail kit and CMA.

 **TIP:** Enclosure panel access diagrams for locating CRUs:

- Front panel: see [Figure 3 \(page 22\)](#) and [Figure 15 \(page 32\)](#)
 - Rear panel: see [Figure 4 \(page 23\)](#)
 - Top: see [Figure 10 \(page 27\)](#), [Figure 13 \(page 29\)](#), and [Figure 14 \(page 30\)](#)
-

 **TIP:** Enclosure dimetric pictorial views:

- Projection from enclosure front panel: see [Figure 1 \(page 19\)](#)
 - Projection from enclosure rear panel: see [Figure 2 \(page 19\)](#)
-

6 Module removal and replacement

Overview

This chapter provides procedures for replacing CRUs (customer-replaceable units), including precautions, removal instructions, installation instructions, and verification of successful installation. Each procedure addresses a specific task.

Following table specifies the time limits for replacement of CRUs. Replacement of CRUs within these time-frames maintains efficient enclosure cooling and hence ensures its optimum performance.

Table 10 CRU replacement durations

CRU	Should be replaced within
PSU	2 minutes after its removal
System fan	2 minutes after its removal
Controller module	45 seconds within its removal, OR insert the controller service blank within 45 seconds to permit servicing of the controller
Storage personality module	35 seconds after its removal
Controller channel fan	35 seconds after its removal
HS expander	2 minutes after its removal
Drive module (HDD or SSD) in main bay	2 minutes after its removal
Drive module (HDD or SSD) in controller module channel	35 seconds after its removal

NOTE: Do not remove a faulty module unless you have the replacement module available and ready for insertion into the slot. This will help you to match above time durations.

ESD precautions

Before you begin *any* of the procedures, consider the following precautions and preventive measures.

Preventing electrostatic discharge

To prevent damage occurring to the system due to electrostatic discharge (ESD), be aware of the precautions to consider when setting up the system or handling parts. A discharge of static electricity from a finger or other conductor may damage system boards or other static-sensitive devices. This type of damage may reduce the life expectancy of the device.

△ CAUTION: Parts can be damaged by electrostatic discharge. Follow these precautions:

- Avoid hand contact by transporting and storing products in ESD-protected containers.
- Keep electrostatic-sensitive parts in their containers until they arrive at ESD-protected workstations.
- Place parts in a static-protected area before removing them from their containers.
- Avoid touching pins, leads, or circuit.
- Always be properly grounded when touching a static-sensitive component or assembly.
- Remove clutter (plastic, vinyl, foam) from the static-protected workstation.

Grounding methods to prevent electrostatic discharge

Several methods are used for grounding. Adhere to the following precautions when handling or installing electrostatic-sensitive parts.

⚠ CAUTION: Parts can be damaged by electrostatic discharge. Use proper anti-static protection:

- Keep the replacement CRU in the ESD bag until needed; and when removing a CRU from the enclosure, immediately place it in the ESD bag and anti-static packaging.
 - Wear an ESD wrist strap connected by a ground cord to a grounded workstation or unpainted surface of the computer chassis. Wrist straps are flexible straps with a minimum of 1 megohm (± 10 percent) resistance in the ground cords. To provide proper ground, wear the strap snug against the skin.
 - If an ESD wrist strap is unavailable, touch an unpainted surface of the chassis before handling the component.
 - Use heel straps, toe straps, or boot straps at standing workstations. Wear the straps on both feet when standing on conductive floors or dissipating floor mats.
 - Use conductive field service tools.
 - Use a portable field service kit with a folding static-dissipating work mat.
-

If you do not have any of the suggested equipment for proper grounding, have an authorized technician install the part. For more information about static electricity or assistance with product installation, See <https://seagate.com/support-home>.

Replacing a PSU module

This section provides procedures for replacing a failed power supply unit (PSU) module. Illustrations in PSU replacement procedures show rear panel views of the enclosure, with the PSU properly oriented for insertion into the rear panel of the enclosure.

⚠ WARNING! Before replacing a faulty PSU, verify its type. Check if it's a BlockPoint PSU or non-BlockPoint PSU. 4U100 enclosure operates smoothly with same type of PSU pair. Use of different type of PSU within same 4U100 enclosure is strictly prohibited.

A single PSU is sufficient to maintain operation of the enclosure. You need not halt operations and completely power-off the enclosure when replacing only one PSU; however, a complete orderly shutdown is required if replacing both units simultaneously.

⚠ CAUTION: Do not remove the cover from the PSU due to danger of electric shock from inside. Return the PSU to your supplier for repair.

See CAUTION bullets regarding *electrostatic discharge* and *anti-static protection* on [page 89](#).

💡 TIP: The illustrations show PSU module replacement as you face the enclosure rear panel. See [Figure 4 \(page 23\)](#) and [Figure 7 \(page 25\)](#). PSU must be replaced within 2 minutes of its removal in order to prevent air loss and maintain optimum enclosure cooling.

Removing a PSU module

△ CAUTION: Removing a power supply unit significantly disrupts the enclosure's airflow. Do not remove the PSU until you have received the replacement module. It is important that all CRU slots are filled when the enclosure is in operation.

Before removing the PSU, disconnect the power from the faulty PSU by physically removing the power cable in order to ensure your system has warning of imminent power shutdown. A faulty PSU must be replaced by a fully operational PSU within 2 minutes of its removal. Ensure that you correctly identify the faulty PSU before beginning the step procedure.

1. Stop all I/O from hosts to the enclosure. See [“Stopping I/O” \(page 107\)](#).
-

💡 TIP: This step is not required for hot-swapping. However, it is required when replacing both PSUs at once.

2. Use management software to shut down any other system components necessary.
-

💡 TIP: This step is not required for hot-swapping. However, it is required when replacing both PSUs at once.

3. Disconnect the two power cables from the PSU power connectors to power OFF the faulty PSU (it has no power switch).
-

△ IMPORTANT: Make sure that you remove the cables from PSU end and not from the PDU end. Ideally, cables of a PSU are attached to different PDUs (See [Figure 68](#)). Removing cables from a single PDU will cut the power of one core of each PSU, but the other core of the PSUs will remain active.

NOTE: Power cables are typically routed to the PSU from the cable management arm (CMA). Verify that the 180° power cable bends lie flat in the CMA baskets. Ensure that the cable lays flat on the CMA shelf and through the cable clip assembly. See [“Routing cables using CMA” \(page 69\)](#).

4. Remove the rear stabilizer bar connected to the enclosure.
5. If replacing a single PSU via hot-swap, proceed to [step 7](#).
6. If replacing both PSUs, verify that the enclosure was shut down using management interfaces, and that the enclosure is powered OFF.
7. Verify that the power cables of the replaceable PSU are disconnected.

- Grasp the PSU handle latch between the thumb and forefinger and press the latch tab down to unlock the handle. Revolve the handle out and downward to lever the PSU out of the enclosure as shown in [Figure 70](#).

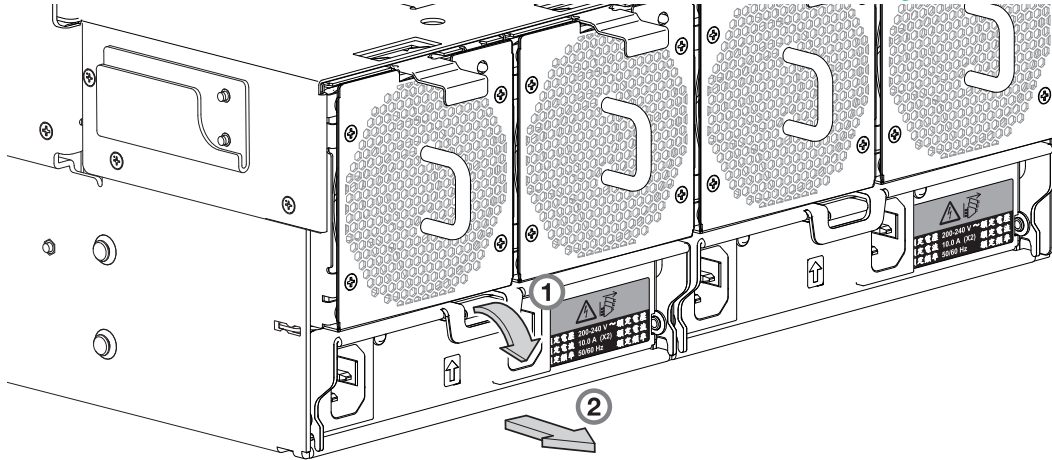

Figure 70 Removing a PSU (1 of 2)

- Grip the handle and withdraw the PSU, taking care to support the base of the module with both hands as you remove it from the enclosure as shown in [Figure 71](#).

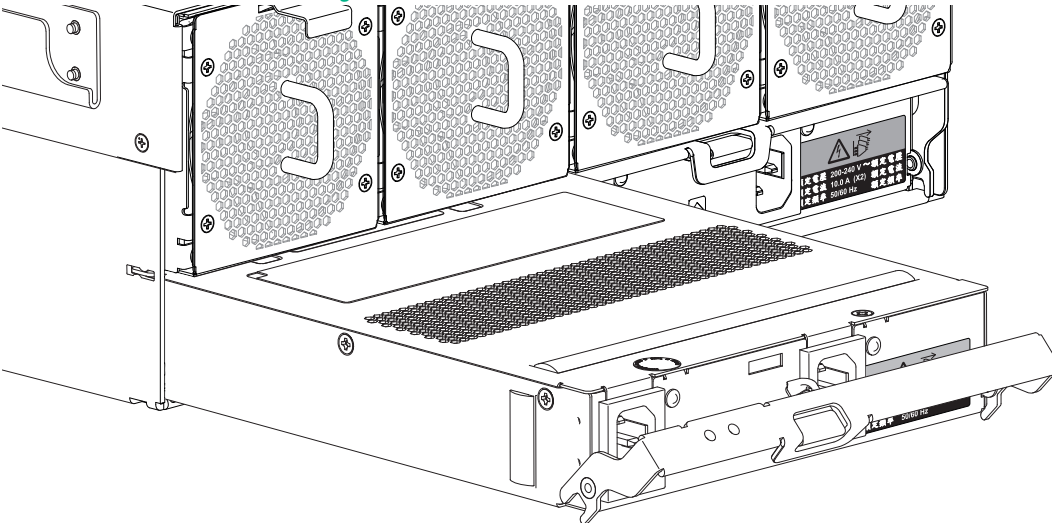

Figure 71 Removing a PSU (2 of 2)

- If you are replacing two PSUs, repeat steps 5 through step 8, being mindful of the illustrations TIP on [page 90](#).

Installing a PSU module

See [Figure 70 \(page 92\)](#) and [Figure 71 \(page 92\)](#) when performing this procedure, but ignore the directional arrows—since you will insert the module into the slot—rather than remove it.

-
- ① **IMPORTANT:** Handle the PSU carefully, and avoid damaging the connector pins. Do not install the PSU if any pins appear to be bent.
-

- Check for damage, especially to all module connectors.

2. With the PSU handle in the open position, slide the module into the enclosure, taking care to support the base and weight of the module with both hands.
3. Lever the module home by manually closing the PSU handle. You should hear a click as the latch handle engages and secures the PSU to its connector on the back of the power midplane.
4. Connect the power cable to the power source and the PSU.
Power cables are typically routed to the PSU from the cable management arm (CMA). Verify that the 180° power cable bends lie flat in the CMA baskets. Route the cables as shown in “Routing cables using CMA” (page 69), ensuring they lay flat on the CMA shelf and through the PSU cable clips assembly. See Figure 4 (page 23).
5. Verify that the bitonal PSU Status LED is ON/green. Verify that cooling fans are spinning with no fail states. Verify that the front panel LED states show no amber module faults.
6. If replacing two PSUs, repeat step 1 through step 6, being mindful of the illustrations TIP on page 90.

Replacing a system fan module

This section provides procedures for replacing a failed system fan module. Illustrations in system fan replacement procedures show rear panel views of the enclosure, with the fan properly oriented for insertion into the rear panel of the enclosure.

If a system fan module fails, the remaining three fans are sufficient to maintain operation of the enclosure. You need not halt operations and completely power-off the enclosure when replacing only one system fan; however, a complete orderly shutdown is required if replacing multiple system fan modules simultaneously.

⚠ CAUTION: Do not remove the cover from the system fan module due to danger from electric shock inside. Return the module to your supplier for repair.

See CAUTION bullets regarding *electrostatic discharge* and *anti-static protection* on page 89.

💡 TIP: The illustrations show system fan module replacement as you face the enclosure rear panel. See Figure 4 (page 23) and Figure 8 (page 26). A System fan module must be replaced within 2 minutes of its removal to prevent air-loss and maintain optimum cooling of the enclosure.

Removing a system fan module

⚠ CAUTION: Removing a system fan module significantly disrupts the enclosure’s airflow. Do not remove the fan until you have received the replacement module. It is important that all fan module slots are filled when the enclosure is in operation.

1. Move any power cords out of the way of System fan modules.
2. Press down on the latch tab to release the fan from its locked position. See detail No.1 in Figure 72 (page 94).

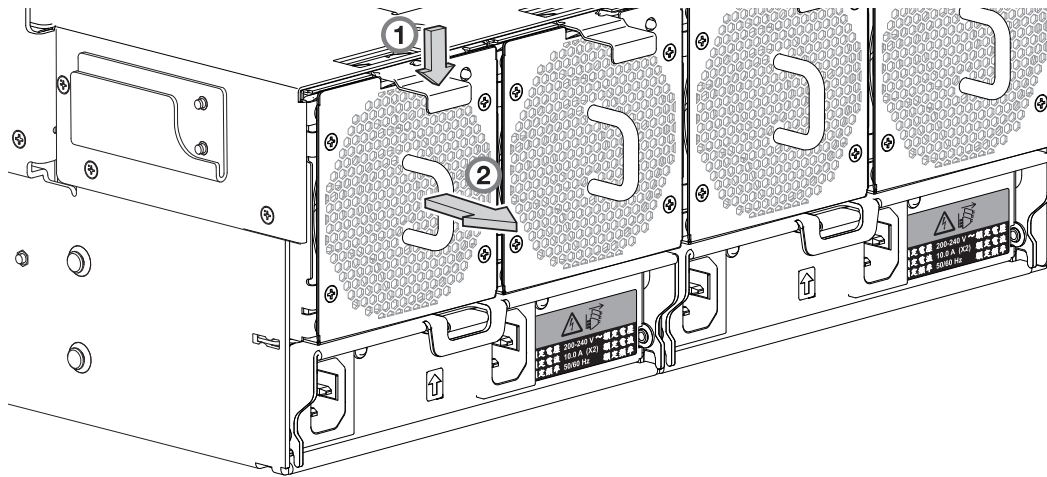

Figure 72 Removing a system fan (1 of 2)

3. Grasp the fan module handle and carefully pull the fan out of its slot. See the detail in [Figure 73](#).

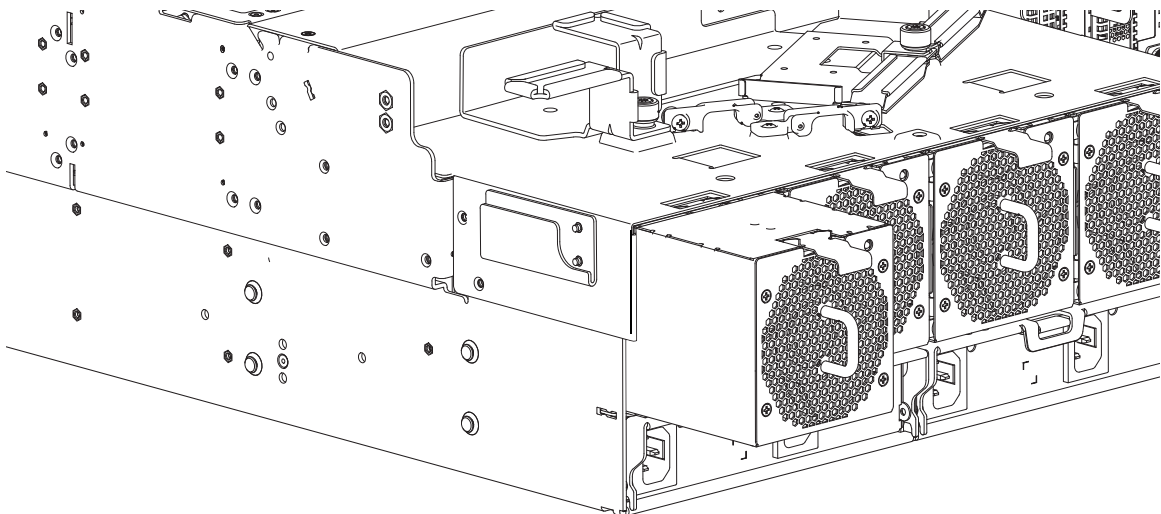

Figure 73 Removing a system fan (2 of 2)

Installing a system fan module

See [Figure 72](#) and [Figure 73](#) when performing this procedure, but ignore the directional arrow—since you will insert the module into the slot—rather than remove it.

① **IMPORTANT:** Handle the system fan carefully, and avoid damaging connectors.

1. Check for damage, especially to all module connectors.
2. Align the system fan module for insertion into its slot, as shown in [Figure 73 \(page 94\)](#).
3. Insert the system fan, and slide the module into the enclosure, taking care to support the base and weight of the module with both hands.

Gently, but firmly, push the fan module into its fully seated position with its mating connector in the enclosure.

4. Verify that the System Fan Status LED is OFF. Verify that the cooling fans are spinning with no fail states. Verify that the front panel LED states show no amber module faults.
5. If replacing multiple fans, repeat [step 1](#) through [step 4](#).

Replacing a controller channel fan module

This section provides procedures for replacing a failed controller channel fan module. Illustrations in controller channel fan replacement procedures show top panel views of the enclosure, with the fan properly oriented for insertion into the top panel of the enclosure, near the Storage personality modules. Remove the top left lid “B” to access the controller channel module fan.

If a controller channel fan module fails, the remaining fan is sufficient to maintain operation of the enclosure. You need not halt operations and completely power-off the enclosure when replacing only one controller module fan.

CAUTION: Do not remove the cover from the controller fan module due to danger from electric shock inside. Return the module to your supplier for repair.

See the CAUTION bullets regarding *electrostatic discharge* and *anti-static protection* on [page 89](#).

TIP: The illustrations show controller fan module replacement as you face the enclosure front and view the top panel. See [Figure 14 \(page 30\)](#) and [Figure 23 \(page 42\)](#). Controller channel fan must be replaced within 35 seconds of its removal in order to prevent air-loss and maintain optimum enclosure cooling.

Removing a controller channel fan module

CAUTION: Removing a Controller module fan module disrupts the enclosure’s airflow. Do not remove the fan until you have received the replacement module. It is important that all CRU module slots are filled when the enclosure is in operation.

1. Remove the top left lid B. Refer to [“Removing enclosure top lid B” \(page 29\)](#).
2. Grasp the latch tab on the interior channel wall of the enclosure, and squeeze the tab against the wall to release the channel fan from its locked position as shown in [Figure 74](#).

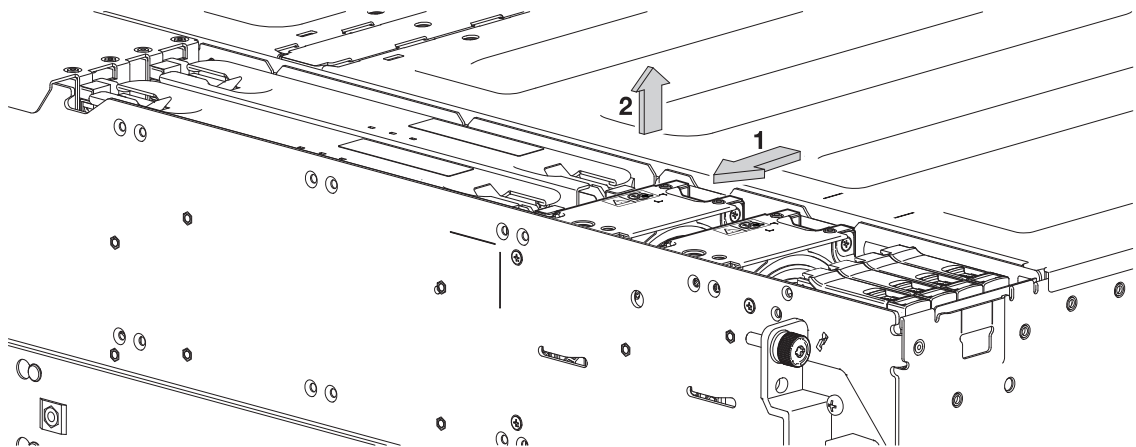

Figure 74 Removing a controller fan (1 of 2)

3. With your other hand, grasp the handle located on the top of the fan, and pull it upwards to remove the fan from its slot as shown in [Figure 75](#).

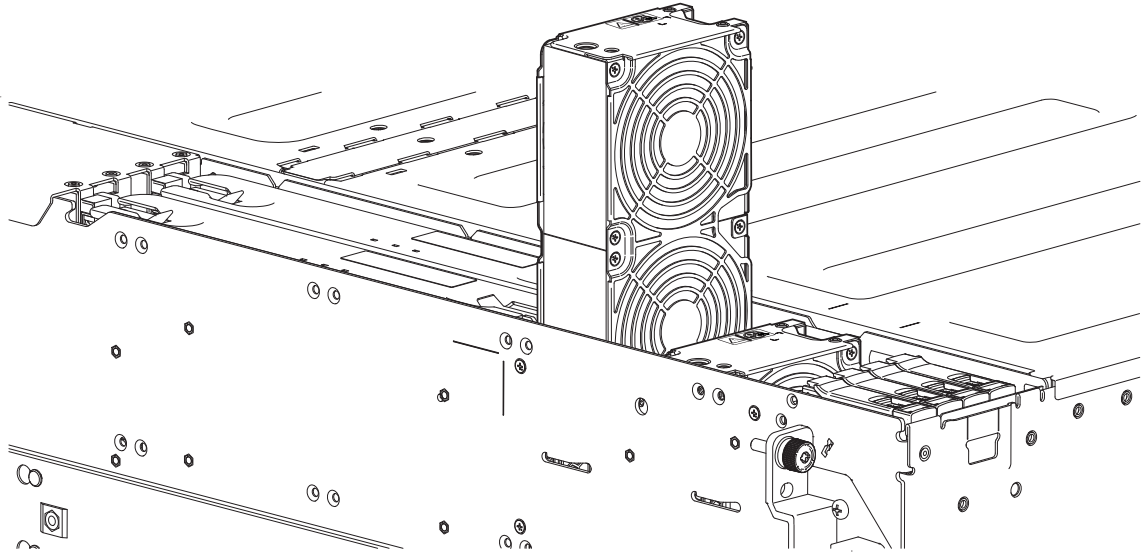

Figure 75 Removing a controller fan (2 of 2)

Installing a controller channel fan module

See [Figure 74 \(page 95\)](#) and [Figure 75 \(page 96\)](#) when performing this procedure, but ignore the directional arrow—since you will insert the fan module into the slot—rather than removing it.

-
- ① **IMPORTANT:** Handle the controller fan carefully, and avoid damaging connectors. The controller channel fan must be inserted with its cable connections facing the enclosure front.
-

1. Check for damage, especially to all module connectors.
2. Align the controller fan module for use in the fan slot that is accessible from the top panel. Make sure that the cable connections are facing the enclosure front panel.
3. Insert the controller fan module into the slot, and gently press down on the module until it seats firmly in its connector.
4. Verify that the Controller Fan Status LED is OFF. Verify that the front panel LED states show no amber color.
5. If replacing multiple fans, repeat [step 1](#) through [step 4](#).

Reattach top lid “**B**” when you complete the procedure.

Replacing a Storage personality module

This section provides procedures for replacing a failed Storage personality module. Illustrations in Storage personality module replacement procedures show top panel views of the enclosure, with the module properly oriented for insertion into its connecting slot in controller channel bay.

One Storage personality module is present for each Controller module. Each Storage personality module possesses a slot where an Controller module fits in. If a Storage personality module fails, the remaining module is sufficient to maintain operation of the enclosure. You need not halt operations and completely power-off the enclosure when replacing only one Storage personality module.

See CAUTION bullets regarding *electrostatic discharge* and *anti-static protection* on [page 89](#).

TIP: The illustrations in this topic show Storage personality module replacement as you face the enclosure front and view the top left panel. Refer [Figure 80 \(page 100\)](#) and [Figure 81 \(page 100\)](#). The Storage personality module must be replaced within 35 seconds from its removal.

Removing the SPM air retention cover

Before removal of any Storage Personality module, you need to remove the air retention cover present above it. Air retention cover has Mylar tabs on one side, and the slots for the metal tabs on the other side ([Figure 76](#)). The Mylar tabs along with the slots locks the air retention cover to the enclosure chassis.



Figure 76 SPM air retention cover

To remove the SPM air retention cover, follow the steps mentioned below.

1. Remove the top left lid B as described in [“Removing enclosure top lid B” \(page 29\)](#).

- Using a blunt tool press the Mylar tabs present below the sheet metal tabs and deflect them upward to make them free from the metal tabs (see [Figure 77](#)).

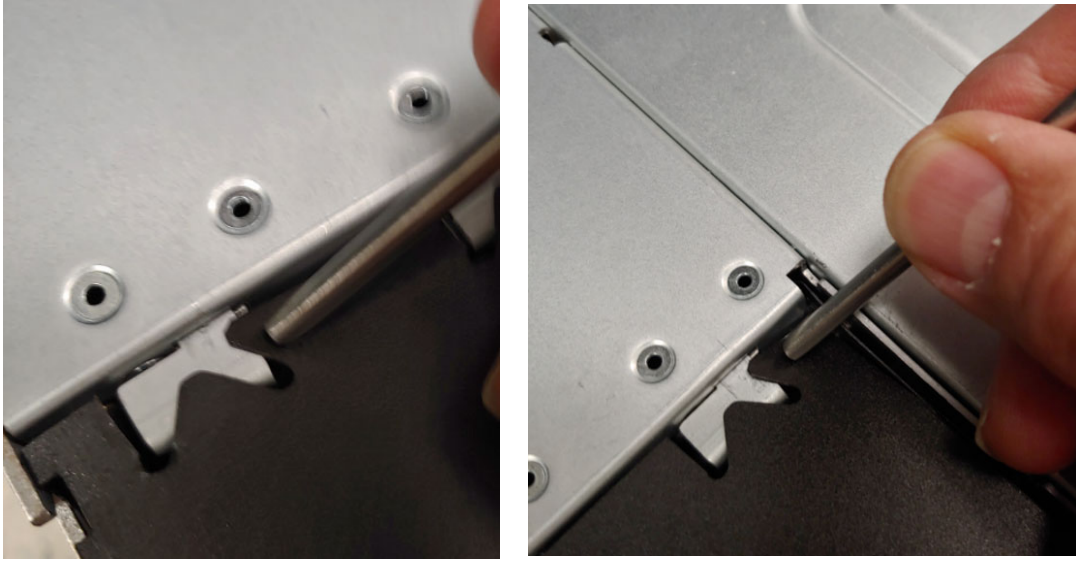

Figure 77 Mylar tabs freed from the metal tabs

- Pull out the side-tabs from the enclosure (see [Figure 78](#)). This makes the Mylar tabs edge of the air retention cover free from the enclosure.

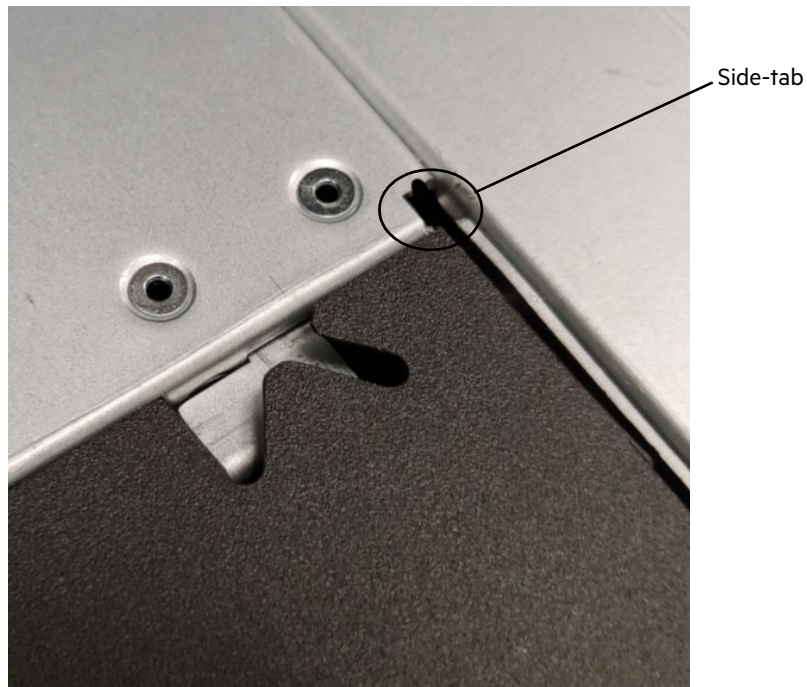

Figure 78 Side-tab removed from the enclosure

- Rotate the free end of the retention cover upward and take the cover out from the metal tabs present on the other end (see [Figure 79](#)).



1. Rotating the air retention cover upward

2. Removing the air retention cover out from the metal tabs

Figure 79 Taking out the other end of the air retention cover from the metal tabs

Removing a Storage personality module

△ **CAUTION:** Removing this hot-swappable Storage personality module disrupts the enclosure's airflow. Do not remove the module until you have received the replacement. It is important that all CRU module slots are filled when the enclosure is in operation.

1. A Storage Personality module is attached to its partner Controller module. To remove a Storage Personality module, you must first disconnect the partner Controller module.
2. Remove the rear stabilizer bar.
3. Remove the Controller module as described in [“Removing a Controller module” \(page 107\)](#) and place it in ESD-protected area.
4. Remove the top left lib B as described in [“Removing enclosure top lid B” \(page 29\)](#) to access the faulty Storage personality module. Amber LED on the faulty Storage personality module will be lit amber.
5. Remove the Air retention cover present on the faulty Storage personality module as described in [“Removing the SPM air retention cover” \(page 97\)](#).

6. Grasp the swing-arms present on both sides of the faulty Storage personality module between your index fingers and thumbs. See step 1 in [Figure 80](#).

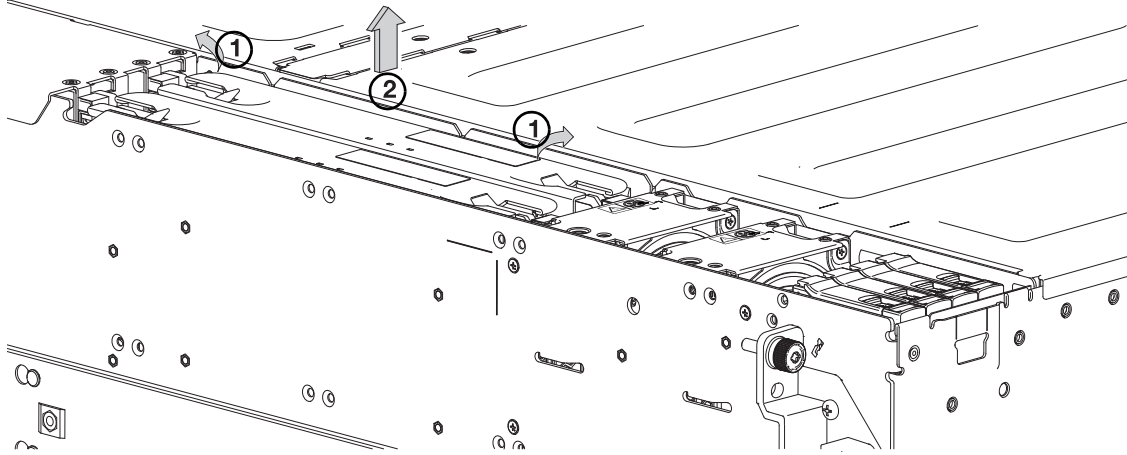

Figure 80 Removing a Storage personality module (1 of 2)

7. Open the swing-arms and pull the Storage personality module up, out from the slot. See [Figure 81](#).

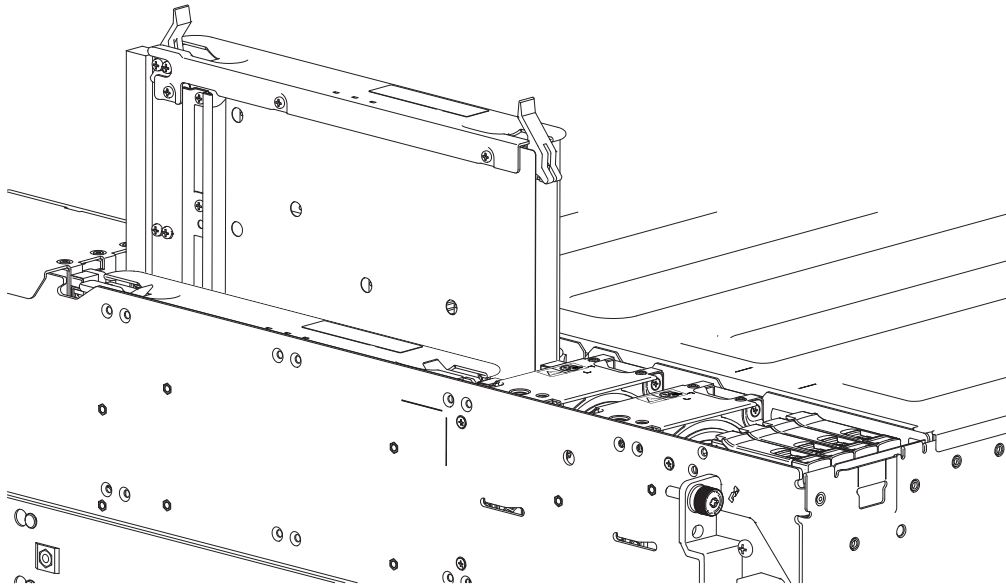

Figure 81 Removing a Storage personality module (2 of 2)

Installing Storage personality module

See [Figure 80](#) and [Figure 81](#) when performing this procedure, but ignore the directional arrow—since you will insert the module into the slot—rather than removing it.

-
- ⓘ **IMPORTANT:** Handle the Storage personality module (SPM) carefully to avoid damage to the connector and swing arms.
-

1. Check for damage, especially to all module connectors.

2. Keeping the Storage personality module vertically straight position, insert the guiding slot (inner/outer) into the chassis wall-support and gently press down the module down until it seats firmly in its slots. Refer [Figure 82](#).

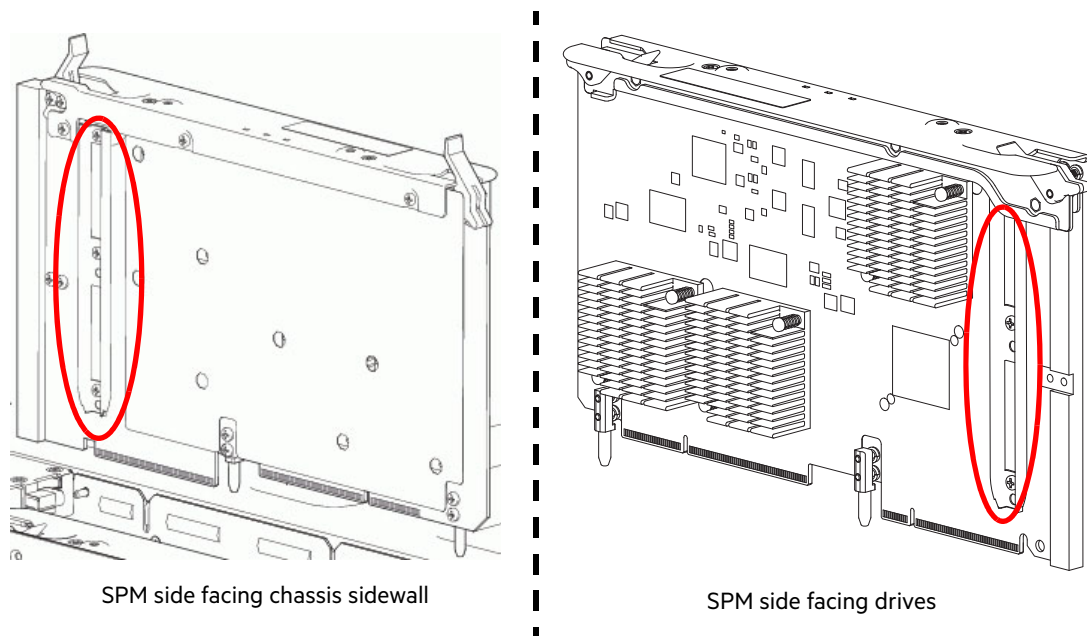

Figure 82 Guiding slots present on the inner and outer side of a Storage personality module

3. Rotate and press the swing-arms inwards to lock the Storage personality module (See [Figure 83](#)).

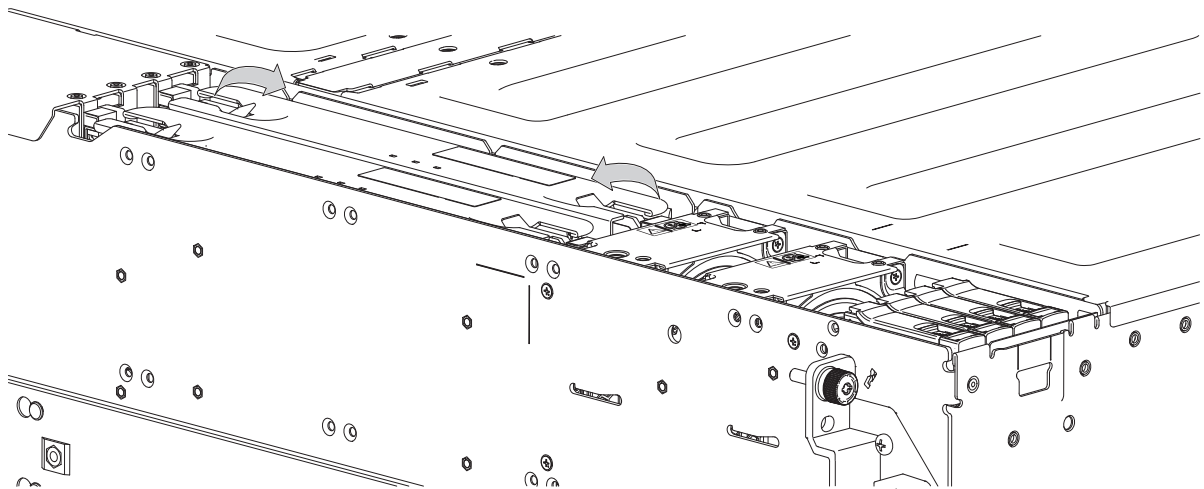

Figure 83 Locking the SPM at its place using swing-arms

4. Insert Controller module back into the chassis and the Storage personality module, and do the required connections.
5. Verify that the Storage personality module fault LED is OFF. Verify that the front panel LED states show no amber module faults.
6. If replacing both Storage personality modules, repeat above procedure.

Reattach top lid “B” after you complete the procedure.

Replacing a HS Expander Module

This section provides procedures for replacing a failed HS Expander module. Illustrations in HS Expander replacement procedures show top panel views of the enclosure, with the module properly oriented for insertion into the top panel of the enclosure near the right wall. In order to remove a HS Expander module, first you need to open the respective half of the top lid A.

If a HS Expander module fails, the remaining modules are sufficient to maintain operation of the enclosure. You need not halt operations and completely power-off the enclosure when replacing only one HS Expander module.

See CAUTION bullets regarding *electrostatic discharge* and *anti-static protection* on [page 89](#).

TIP: The illustrations show HS Expander module replacement as you face the enclosure front and view the top panel. See [Figure 10 \(page 27\)](#) and [Figure 14 \(page 30\)](#). The replacement procedure must be completed within 2 minutes.

Removing a HS Expander module

CAUTION: Removing this hot-swappable PCBA disrupts the enclosure's airflow. Do not remove the PCBA until you have received the replacement. It is important that all CRU module slots are filled when the enclosure is in operation.

1. Remove the top lid "A" to access the HS Expander module. See [Figure 10 \(page 27\)](#).
2. On the faulty HS Expander, grasp each of the two plastic swing-arms between thumb and index finger as shown in [Figure 84](#).

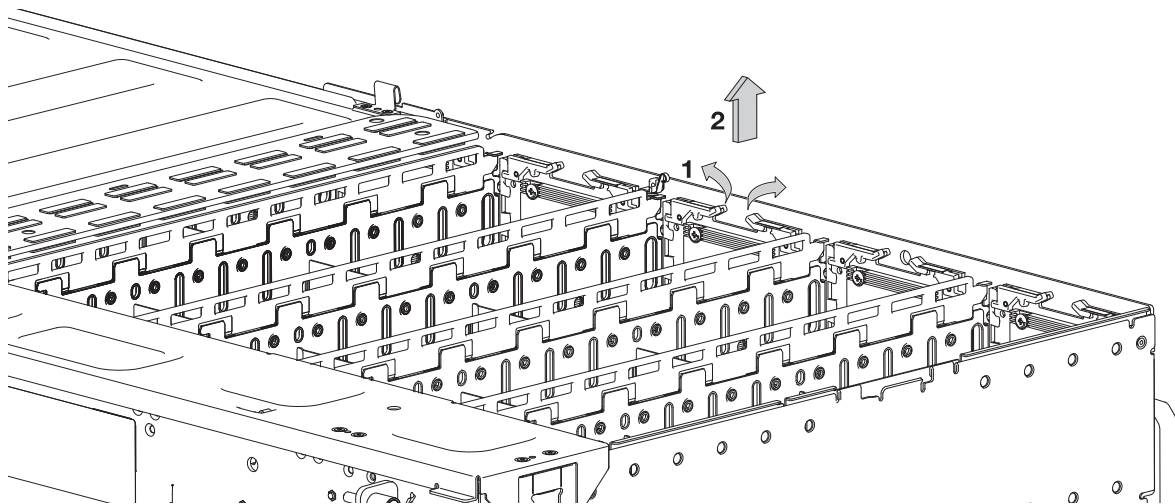

Figure 84 Removing a HS Expander (1 of 2)

3. Revolve each swing-arm upward to release the PCBA carrier from its slot as shown in [Figure 85](#).

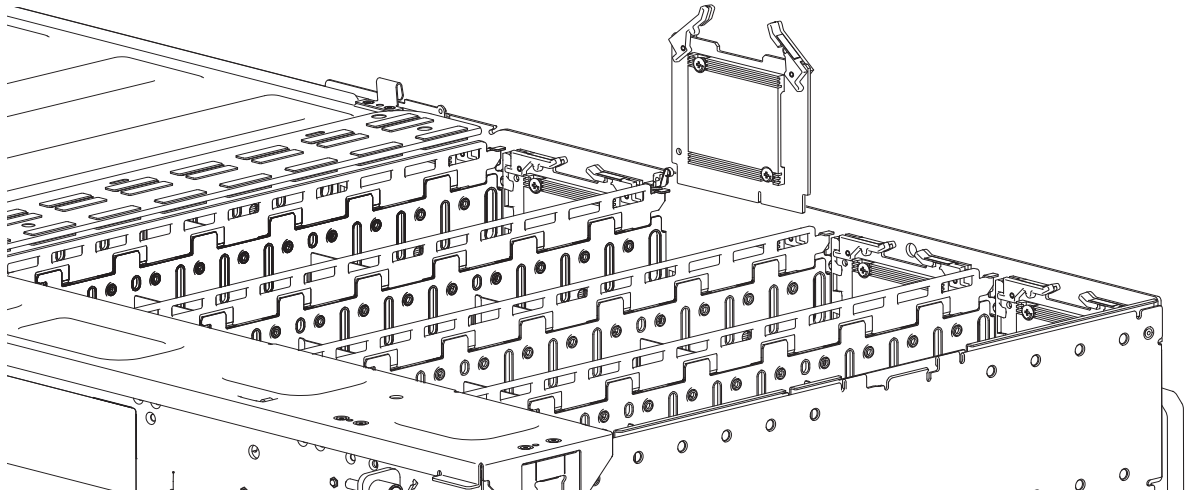

Figure 85 Removing a HS Expander (2 of 2)

4. While grasping the swing-arm handle, pull upwards to lift the HS Expander and remove it from its slot.

Installing an HS Expander module

See [Figure 84](#) and [Figure 85](#) when performing this procedure, but ignore the directional arrow—since you will insert the module into the slot—rather than remove it.

ⓘ **IMPORTANT:** Handle the HS Expander module carefully to avoid damage to the connector and swing arms.

1. Check for damage, especially to all module connectors.
2. Align the HS Expander module for use in the module slot that is accessible from the top panel along the right wall of the enclosure.
3. Insert the HS Expander module into the slot, and gently press down on the module until it seats firmly in its connector.
4. Verify that the HS Expander Status LED is OFF. Verify that the front panel LED states show no amber module faults.
5. If replacing multiple HS Expanders, repeat [step 1](#) through [step 4](#).
6. Reattach top lid “A” when you complete the procedure.

Replacing a drive module

A drive module consists of a disk in a carrier. Disk Drive in Carrier (DDIC) modules are hot-swappable, which means they can be replaced without halting I/O to the disk groups, or powering OFF the enclosure. The new disk must be of the same type, and possesses capacity equal to or greater than the one being replaced. Otherwise, the storage system cannot use the new disk to reconstruct the disk group. Remove the top lid “A” to access DDICs. See [Figure 10 \(page 27\)](#) for enclosure lid locations and labeling. Reattach top lid “A” when the procedure is completed. To access SSDs (i.e. 97th drive to SSD 100th drive), remove top lid “B”, and reattach it when the procedure is completed. See [Figure 14 \(page 30\)](#) for disk slot indexing.

⚠ **CAUTION:** Removing a drive module impacts the airflow and cooling ability of the enclosure as you need to lift the lid. If the internal temperature exceeds acceptable limits, the enclosure may overheat and automatically shut down or restart.

See CAUTION bullets regarding *electrostatic discharge* and *anti-static protection* on [page 89](#).

TIP: The illustrations show disk module replacement within the drive slots as you view the enclosure top panel. See [Figure 14 \(page 30\)](#) for disk drive slot numbering. Although the DDIC with LFF disk is used in the illustrated procedures, the procedures also apply to the DDIC with SFF disk and adapter.

Removing a LFF drive carrier module

1. Press the latch in the carrier handle towards the handle hinge to release the carrier handle as shown below.

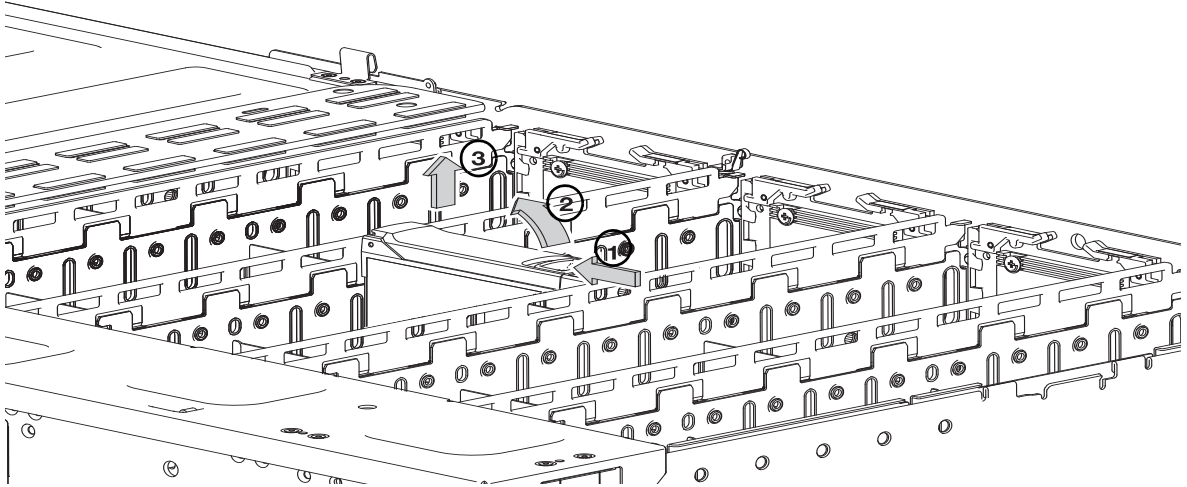

Figure 86 Removing a LFF drive module (1 of 2)

2. Revolve the handle outward to lever the module out of its connector on the baseplane.

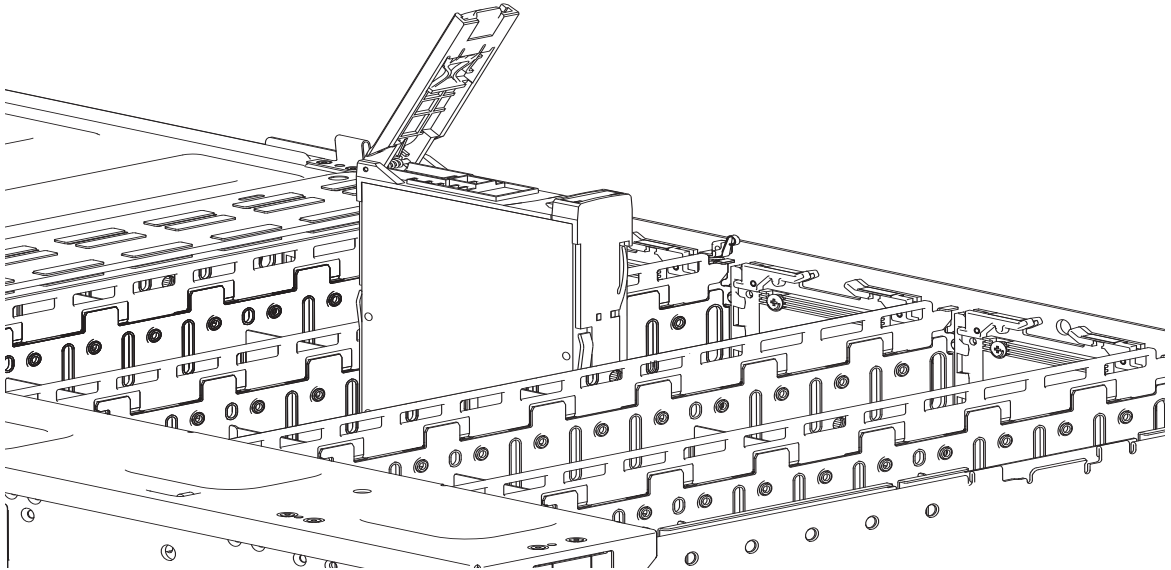

Figure 87 Removing a LFF drive module (2 of 2)

3. Lift and remove the module fully from the drive slot.

Installing a LFF drive carrier module

1. Release the drive carrier handle by pressing the latch in the carrier handle towards the handle hinge as shown below.

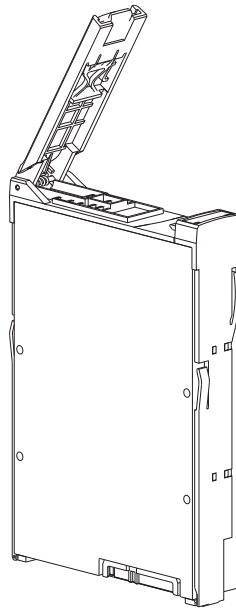

Figure 88 LFF drive carrier module in open position

2. Identify the drive slot in the enclosure in which you want to insert the drive. Refer [Figure 14 \(page 30\)](#) to understand drive slot numbering.
3. Insert the drive carrier module into the enclosure chassis, above the appropriate drive slot. Make sure that the drive is held vertically with the carrier latch positioned at the top, and the carrier hinge is toward the back of the enclosure as shown in [Figure 89](#).

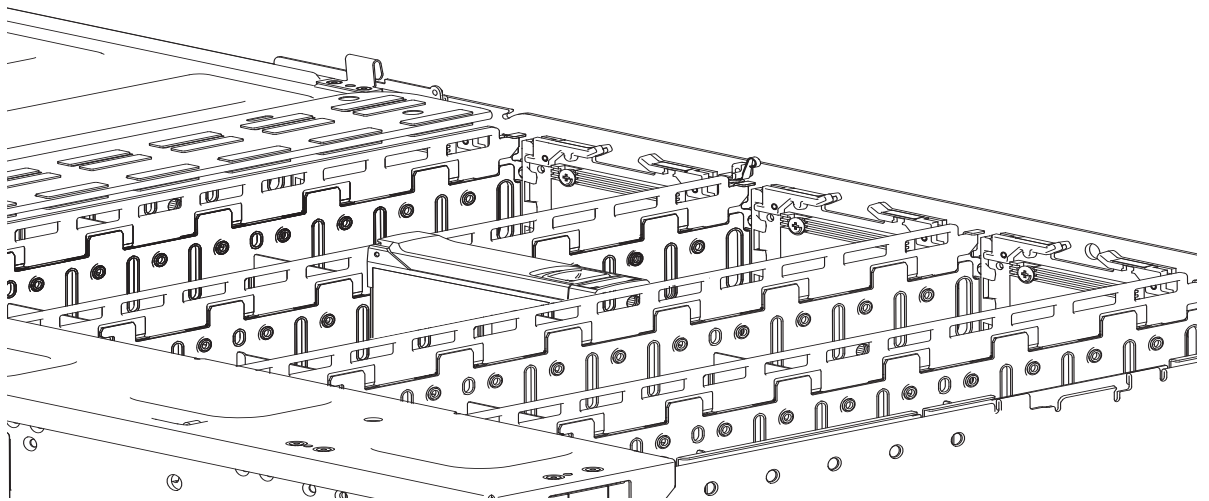

Figure 89 Installing a LFF drive carrier module

4. Slide the drive carrier fully into the disk slot until the handle fully engages. The camming foot on the carrier will engage into a slot in the enclosure. You should hear a click as the latch handle engages and locks it.
5. Verify that the amber Fault LED on the disk module handle is OFF. Verify that the front panel LED states show no amber module faults.

Replacing a Controller module

In a dual-controller configuration, controller modules are hot-swappable, which means you can replace one module without halting I/O to disk groups, or powering OFF the enclosure. In this case, the second module takes over operation of the storage system until you install the new module.

You may need to replace an Controller module when:

- The Fault LED is illuminated
- Logs or events in the firmware indicate a problem with the module
- Troubleshooting indicates a problem with the module

Before you begin

Removing a Controller module from an operational enclosure significantly changes air flow within the enclosure. Openings must be covered for the enclosure to cool properly. If you need to replace a controller module, leave it in place until the replacement is ready to be installed. If you need to remove the controller module in order to replace a component on the controller or to remove a Storage personality module, you must insert a foam Controller module blank in the Controller module slot and leave the blank in place until the controller module can be reinserted. [Figure 90](#) shows the Controller module Foam blank.

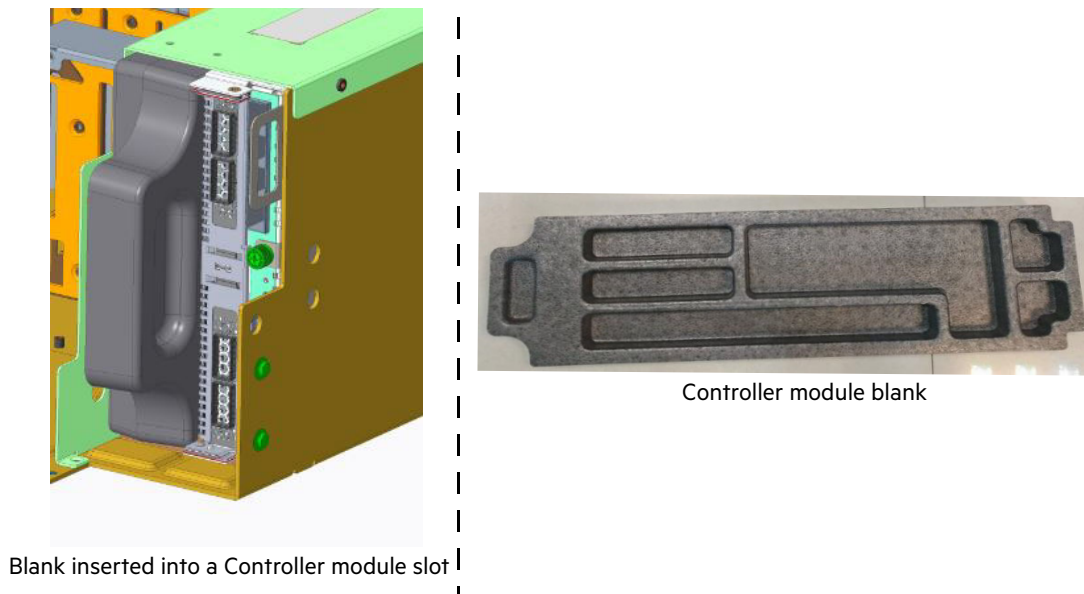

Figure 90 Controller module blank inserted after removing a Controller module

If parts are stored in the Controller module blank, remove the parts before installing the blank in the Controller module slot. If you are replacing both Controller modules in an enclosure, record configuration settings before installing the new controller modules.

See [“Removing a Controller module” \(page 107\)](#), and [“Installing an Controller module” \(page 111\)](#) for instructions about installing an additional controller module.

Verifying component failure

- Check Module Fault LED (No. 7 in [Figure 15](#))– front of enclosure: amber = Fault condition.
- Check Fault LED (See [Figure 19](#))– back of enclosure on Controller module face plate): amber = Fault condition.

Stopping I/O

When troubleshooting disk drive and connectivity faults, stop I/O to the affected disk groups from all hosts as a data protection precaution. As an additional data protection precaution, it is helpful to conduct regularly scheduled backups of your data.

ⓘ **IMPORTANT:** Stopping I/O to a disk group is a host-side task, and falls outside the scope of this document.

When on-site, you can verify that there is no I/O activity by briefly monitoring the system LEDs; however, when accessing the storage system remotely, this is not possible.

Removing a Controller module

ⓘ **IMPORTANT:** Considerations for removing Controller modules:

- You may hot-swap a single controller module in an operational enclosure, provided you first shut down the faulty controller.
- If replacing both controller modules, you must adhere to the instructions provided in “Before you begin” (page 106), and perform an orderly shutdown of the enclosure.
- Before removing a faulty module ensure that you have a replacement Controller module ready to insert in the its slot. In the absence of replacement controller module, make sure you have service blank ready to insert (see Figure 90) in the slot.

See the CAUTION bullets regarding *electrostatic discharge* and *anti-static protection* on page 89.

Illustrations in the Controller module replacement procedures show rear panel views of the enclosure, and Controller modules are properly aligned for insertion into the rear panel of the enclosure.

1. Locate the enclosure whose ID LED (enclosure front panel – left side) is illuminated, and within the enclosure, locate the Controller module whose ID LED present on its face plate is illuminated.
2. Disconnect any cables connected to the Controller module.
Label each cable to facilitate re-connection to the replacement Controller module.
3. Unlock the Controller module latch handle by turning the thumbscrew counter-clockwise as shown in detail No.1 in Figure 91.
Take care not to remove the thumbscrew from the Controller module latch handle.

4. Grasp the latch handle between the thumb and index finger and pull. Revolve the handle out and downward to pull the Controller module out of the enclosure as shown in details No.2 and No.3 in [Figure 91 \(page 108\)](#).

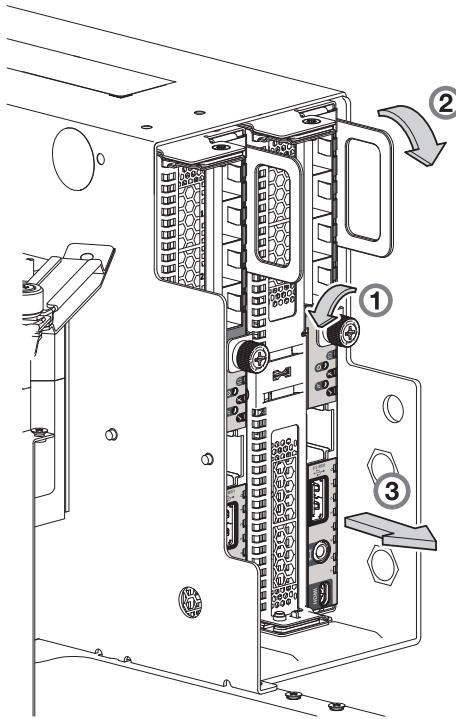

Figure 91 Removing a Controller module (1 of 2)

5. Grip the latch handle and ease the Controller module forward from the slot as shown within [Figure 92 \(page 108\)](#).
6. Place both hands on the controller body, and pull it straight out of the enclosure such that the controller remains level during removal.

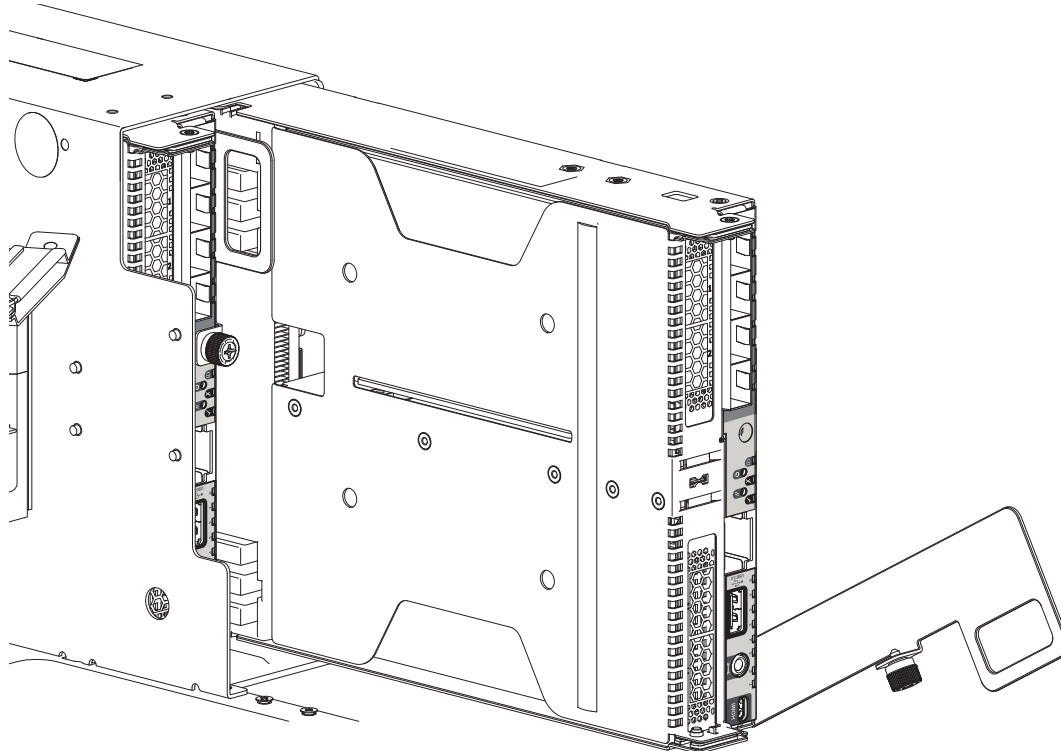

Figure 92 Removing a Controller module (2 of 2)

Installing a PCIe card in a controller module

Each Controller module has 2 slots for PCIe cards.

Adding external PCIe cards

To add a PCIe card to a Controller module, follow the steps mentioned below.

1. Remove the appropriate Controller module out of the enclosure. See “[Removing a Controller module](#)” (page 107).
2. Remove the two screws present on the sides of the Controller module (see [Figure 93](#)).



Figure 93 Removing blank cover screws

3. After making sure that you have removed two screws present on the sides, loose the center locking screw and pull up the metal cover (see [Figure 94](#)).

△ CAUTION: An attempt to remove the metal cover without removing the side-screws can damage the metal cover. You must remove two screws on the sides before touching the central screw.



Figure 94 Losing center locking screw

4. Insert the PCIe card in the PCIe riser card slot present behind the metal cover.



Figure 95 Inserting PCIe card (Ethernet card in this case) into the PCIe riser card

5. Once PCIe card is fixed into the slot, fix the metal cover back to the Controller module by following the [step 1](#) through [step 3](#) in the reverse order.

Installing an Controller module

See the CAUTION bullets regarding *electrostatic discharge* and *anti-static protection* on [page 89](#).

△ **CAUTION:** If passive copper cables are connected, the cable must not have a connection to a common ground/earth point.

NOTE: When performing the following procedure, see [Figure 92](#) and [Figure 91 \(page 108\)](#) while ignoring the directional arrow. For installation, the Controller module will travel in the opposite direction relative to the arrow shown.

1. Examine the Controller module for damage, and closely inspect the interface connector. Do not install if the pins are bent.
2. If a Controller module blank was inserted in the Controller module slot, remove it.
3. Grasp the Controller module using both hands, and with the latch in the open position, orient the module and align it for insertion into the target Controller module slot.
4. Ensuring the Controller module is oriented as shown in the illustrations, slide it into the enclosure as far as it will go. An Controller module that is only partially seated will prevent optimal performance of the enclosure. Verify that the module is fully seated before continuing.
5. Set the module in position by manually closing the latch.
You should hear a click as the latch handle engages and secures the Controller module to its connector on the back of the Storage personality module. Tighten the thumbscrew to secure the latch in place.
6. Reconnect the cables.

NOTE: Verify that the firmware in both Controller module is compatible.

Verifying component operation

Verify that there are no Controller module fault LEDs on the enclosure front panel or the Controller module faceplate.

A Technical specifications

Enclosure dimensions

Table 11 4U100 enclosure dimensions

Specification	Metric units	Imperial units
Height (including top cover)	177.8 mm	7 in
Width (excluding ears and rails)	441 mm	17.36 in
Depth (including handles, excluding cables)	1,170 mm	46.06 in

Enclosure weights

Table 12 Exos AP 4U100 component weights

CRU/component	Metric units (Kg)	Imperial units (lb)
Storage enclosure (enclosure plus midplane, but no CRU modules)	36.2	79.8
LFF DDIC drive module (3.5" LFF drives or 2.5" SFF disk with LFF adapter)	Up to 0.82	Up to 1.8
SFF DDIC drive module (2.5" SFF drive)	Up to 0.27	Up to 0.6
Power Supply Unit (PSU)	02.25	04.96
System fan module	0.70	01.54
Controller module	04.30	09.48
Controller channel fan module	0.62	01.37
Storage personality module	0.65	01.43
HS expander module	0.09	0.20
Standard Cable Management Arm (CMA) and hardware kit	0.91	2.0
High Capacity Cable Management Arm (CMA) and hardware kit	0.97	2.14
Rail kit (left/right) and hardware kit	06.76	14.90

NOTE:

Weights shown are nominal, and subject to variances.

DDIC weight varies depending on the drive model and capacity used. Value used is the heaviest DDIC currently qualified for the Exos AP 4U100.

Scale calibration may affect measured weights.

Table 13 Exos AP 4U100 total weights

CRU/component	Metric units (Kg)	Imperial units (lb)
Storage enclosure with CRUs, but no DDICs	55.4	122
Storage enclosure with CRUs, 96 LFF DDICs, and 4 SFF DDICs	135	298
Storage enclosure with CRUs, 96 LFF DDICs, 4 SFF DDICs, Standard CMA kit, and rack rail kit	143	315

NOTE: The CRUs included with the Storage enclosure in the table above are (2) PSUs, (4) system fan modules, (2) Controller modules, (2) Storage Personality modules, (2) Controller bay fan modules, and (8) HS expander modules. Weight totals subject to variance in individual component weights. Weight total changes depending on the number of DDIC modules installed. Weight totals with DDICs shown are for the maximum number of DDICs supported by the storage enclosure. Weight totals do not include power, SAS, or serial cables as those cables can have a range of lengths.

Environmental requirements

Table 14 Ambient temperature and humidity

Specification	Temperature range	Relative humidity
Operating	5°C to 35°C (41°F to 95°F, derated by 1°C per 300m above 900m) (Seagate ASHRAE 2015 Class A2)	-12°C DP/10 to 80% (Max) (Non-condensing)
Non-operating	-40°C to +70°C (-40°F to +158°F) (Max rate of change: 20°C)	-12°C DP/5 to 100% (Max) (Non-condensing)

Specification	Measurement/description
Airflow	System must be operated with low pressure rear exhaust installation. Back pressure created by rack doors and obstacles not to exceed 5Pa (0.5 mm H ₂ O)
Altitude, operating	-100 to 3,048 meters (0 to 10,000 feet). Maximum operating temperature is derated by 1°C for each 300 m above 900 m (2952.76 feet)
Altitude, non-operating	-100 to 12,192 m (-328 to 40,000 feet)
Shock, operating	3.0 g, 11 ms (per axis)
Shock, non-operating	20.0 g, 7ms, 10 shock pulses (2 shocks per axis X, Y in positive and negative direction, and 2 shocks in positive Z axis)
Vibration, operating	0.18G _{rms} 5 Hz to 500 Hz, 30 min per axis to a ruggedized standard of 0.31G _{rms} , 1 Hz to 100 Hz, 120 min per axis
Vibration, non-operating	0.54 G _{rms} 6Hz to 200 Hz (ISTA 3E)
Vibration, relocation	Same as non-operating vibration
Acoustics	4U enclosures: Sound power operating ≤ 8.5 Bels LW _{Ad} @ 23°C
Orientation and mounting:	1.2 m rack mount (4 EIA units)
• Rack rails	To fit 1.2 m depth racks compliant with the SSI server rack specification
• Rack characteristics	Back pressure not exceeding 5Pa (~0.5 mm H ₂ O)

Power supply unit specifications

Table 15 Power cooling module specifications

Specification	Measurement/description
Dimensions (size)	38.7 mm high x 170.85 mm wide x 222.2 mm long: <ul style="list-style-type: none">• X-axis length: 170.85 mm (6.72 in)• Y-axis length: 38.7 mm (1.52 in)• Z-axis length: 222.2 mm (8.74 in)
Maximum output power	3200 W
Voltage range	200–240 VAC rated
Frequency	50Hz-60Hz
Maximum inrush current	55A (5ms)
Power conversion efficiency	≥ 94% @ 230 VAC (50% load)
Harmonics	Meets EN61000-3-2 (EU), EN 31000-3-3 (EU), EN 55024 (EU), KN 24/KN 35 (S. Korea)
Output	+5 V @ 42A, +12 V @ 164A, +5 V standby voltage @ 3.5A
Hot swappable	Yes
LEDs	Single bi-color status LED (amber/green)

B Standards and regulations

International standards

The enclosure system complies with the requirements of the following agencies and latest editions of the following standards:

- CE to EN 60950-1
- CB report to IEC 60950-1
- UL & cUL to UL 60950-1

Potential for radio frequency interference

USA Federal Communications Commission (FCC)

Notice

This equipment has been tested and found to comply with the limits for a class A digital device, pursuant to Part 15 of the FCC rules. These limits are designed to provide reasonable protection against harmful interference when the equipment is operated in a commercial environment. This equipment generates, uses, and can radiate radio frequency energy, and if not installed and used in accordance with the instruction manual, may cause harmful interference to radio communications. Operation of this equipment in a residential area is likely to cause harmful interference, in which case the user will be required to correct the interference at his or her expense.

Properly shielded and grounded cables and connectors must be used in order to meet FCC emission limits. The supplier is not responsible for any radio or television interference caused by using other than recommended cables and connectors or by unauthorized changes or modifications to this equipment. Unauthorized changes or modifications could void the user's authority to operate the equipment.

This device complies with Part 15 of the FCC Rules. Operation is subject to the following two conditions: (1) this device may not cause harmful interference, and (2) this device must accept any interference received, including interference that may cause undesired operation.

European regulations

This equipment complies with European Regulations EN 55032 Class A: Limits and Methods of Measurement of Radio Disturbance Characteristics of Information Technology Equipment and EN50082-1: Generic Immunity.

Safety compliance

Table 16 Safety compliance specifications

System product type approval	UL/cUL/CE
Safety compliance	UL 60950-1
	CAN/CSA-C22.2 No. 60950-1-07
	EN 60950-1
	IEC 60950-1
	CCC (China PRC - CCC Power Supplies)
	BIS (India - BIS PSU and system)

EMC compliance

Table 17 EMC compliance specifications

Emissions	FCC CFR 47 Part 15 Subpart B Class A (USA)
	ICES/NMB-003 Class A (Canada)
	EN 55032:2012 Class A (EU)
	AS/NZS CISPR 22/CISPR 32 Class A (Australia/New Zealand)
	VCCI Class A (Japan)
	KN 22/KN 32 Class A (S. Korea)
	CNS 13438 Class A (Taiwan)
Harmonics	EN 61000-3-2 (EU)
Flicker	EN 61000-3-3 (EU)
Immunity	EN 55024 (EU)
	KN 24/KN 35 (S. Korea)

AC power cords/universal jumper cords

Table 18 AC power cord and universal jumper cord specifications

1	United States and Canada	
	Must be NRTL Listed (National Recognized Test Laboratory – e.g., UL)	
	Cord type	SVT or SJT, 14 AWG, 3 conductor, 2.5 meters minimum length
	Plug	NEMA 6–15P grounding-type attachment plug rated 240V 15A
		or
		IEC 320, C-14, 250V, 15A or 16A
	Socket	IEC 320, C-13, 250V, 15A or 16A
2	General requirements: Europe and others	
	Cord type	Harmonized, H05-VVF, 15A or 16A, 250V, 14 AWG, 3*1.5sq mm
	Socket	IEC 320, C-13/C-14, 250V, 15A or 16A

① **IMPORTANT:** The plug and the complete power cable assembly must meet the standards appropriate to the country, and must have safety approvals acceptable in that country.

- Countries include the US, Canada, EU/NEMA, Mexico, Argentina, AUS/NZ, Japan, South Korea, Brazil, Vietnam, China, India, and EAC.
- Standards include RoHS, VDE, and low halogen.

Environmental Standards

- The RoHS Directive (2011/65/EU)
- The WEEE Directive (2012/19/EU)
- The REACH Directive (EC) No. 1907/2006

Recycling of Waste Electrical and Electronic Equipment (WEEE)

At the end of the product's life, all scrap/waste electrical and electronic equipment should be recycled in accordance with national regulations applicable to the handling of hazardous/toxic electrical and electronic waste materials.

Contact your supplier for a copy of the Recycling Procedures applicable to your country.

-
- ⓘ **IMPORTANT:** Observe all applicable safety precautions detailed in the preceding chapters when dismantling and disposing of this equipment.
-

C Enclosure packaging

Supported packaging configurations are included for reference. Identify your packaging configuration from the palletized enclosure ship kit assemblies shown below. Read the documentation provided in your ship kit before unpacking, disposing of, or storing packing materials. See [“Unpacking the enclosure” \(page 47\)](#).

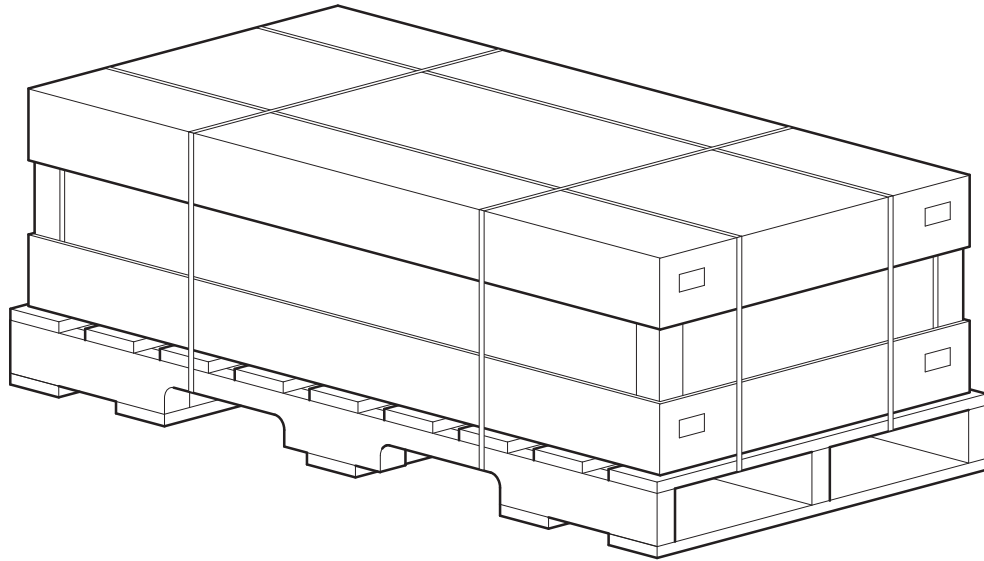

Figure 96 4U100 enclosure packed in 3-piece box with pallet

[Figure \(page 120\)](#) shows an illustrated parts catalog (IPC) representation of the enclosure master container to complement the assembly view shown above.

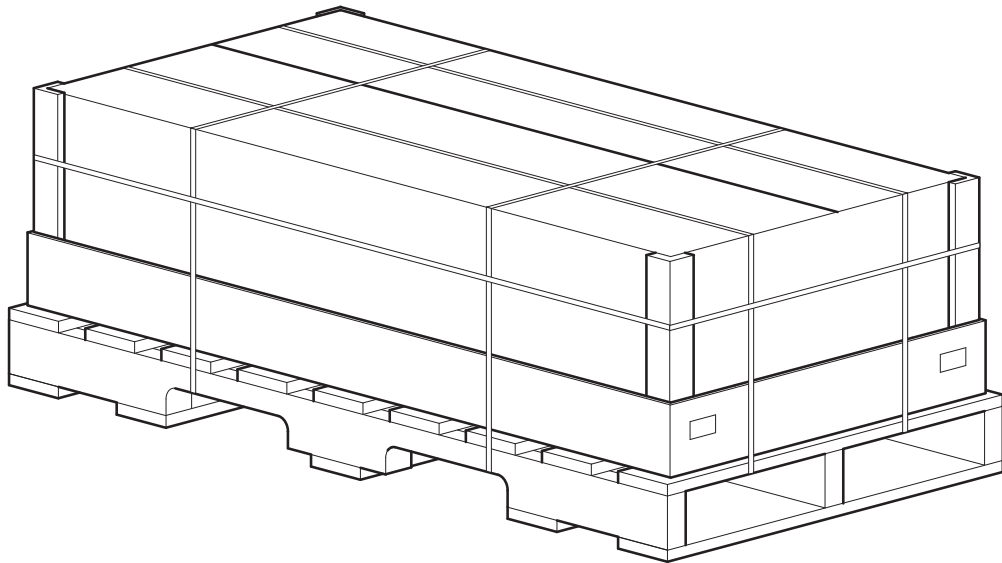
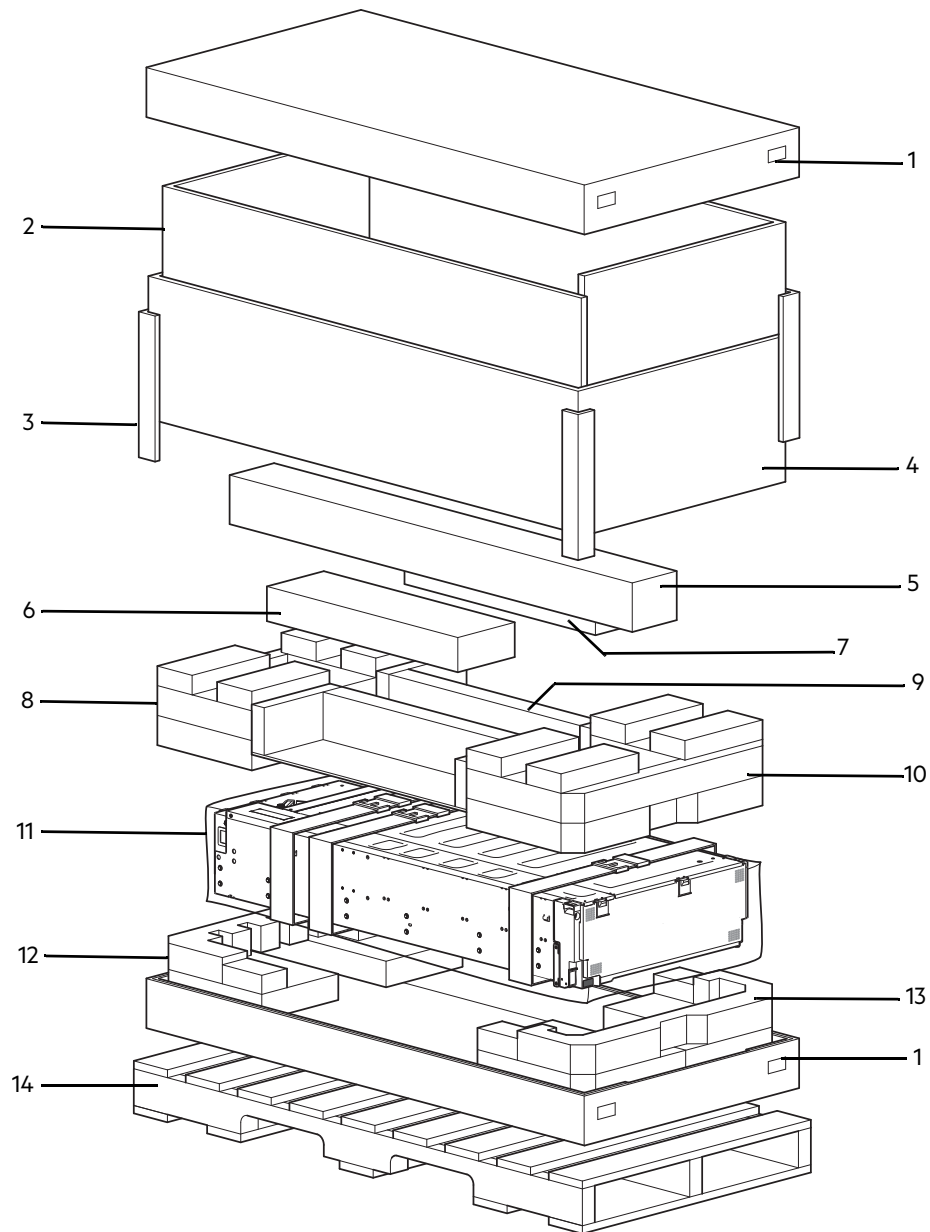

Figure 97 4U100 enclosure packed in RSC box with pallet

The Regular Slotted Container (RSC) box option is shown directly above. [Figure \(page 121\)](#) shows an illustrated parts catalog representation of the RSC enclosure master container. This box uses a split flap-style, as opposed to the removable lid shown in [Figure 96 \(page 118\)](#). The RSC configuration differs from the 3-piece configuration: it does not include the rail kit box, CMA box, or accessory box. These items are provided separately for this configuration.

- ⓘ **IMPORTANT:** Drive modules are packaged separately from the Exos AP 4U100, and are available in different assortments (single, 12-pack, 24-pack). Do not populate disk slots until the enclosure has been installed in the rack using a suitable mechanical lift. See the CAUTION on [page 16](#) and [“Populating drive slots” \(page 30\)](#).
-



No.	Component description	Qty.	No.	Component description	Qty.
1	Base/lid, cardboard	2	8	Foam, inner, drawer rear, top	1
2	Insert, strength L, cardboard	2	9	Insert, CMA holder, cardboard	2
3	Edge protector, height, each corner	4	10	Foam, inner, drawer front, top	1
4	Insert, wall, cardboard	1	11	Plastic bag (with enclosure/belt straps)	1
5	Rail kit box	1	12	Foam, inner, drawer rear, bottom	1
6	Box, accessory kit	1	13	Foam, inner, drawer front, bottom	1
7	CMA box	1	14	Custom pallet, wood	1

Figure 98 Unpacking the enclosure: 3-piece box with packing

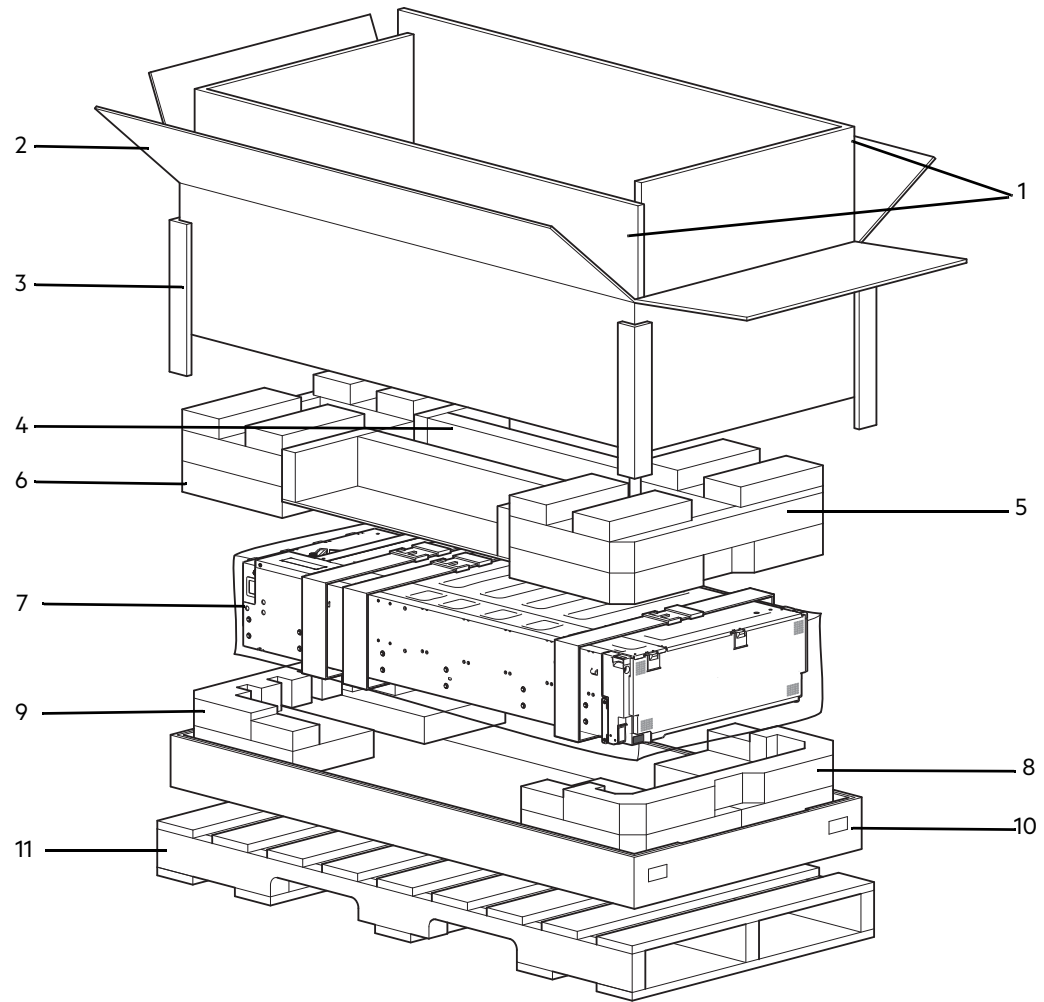

No.	Component description	Qty.	No.	Component description	Qty.
1	Insert, strength L, cardboard	2	7	Plastic bag (with enclosure/belt straps)	1
2	Lid, cardboard with AW	1	8	Foam, inner, drawer front, bottom	1
3	Edge protector, height, each corner	4	9	Foam, inner, drawer rear, bottom	1
4	Insert, CMA holder, cardboard	2	10	Base, cardboard	1
5	Foam, inner, drawer front, top	1	11	Custom pallet, wood	1
6	Foam, inner, drawer rear, top	1			

Figure 99 Unpacking the enclosure: RSC box with packing

D BIOS POST Codes

Introduction

This chapter gives the codes for Power On Self Test (POST). These are shown on the POST LEDs on the back of the controller, as well as, the System BIOS shows them on the Console screen.

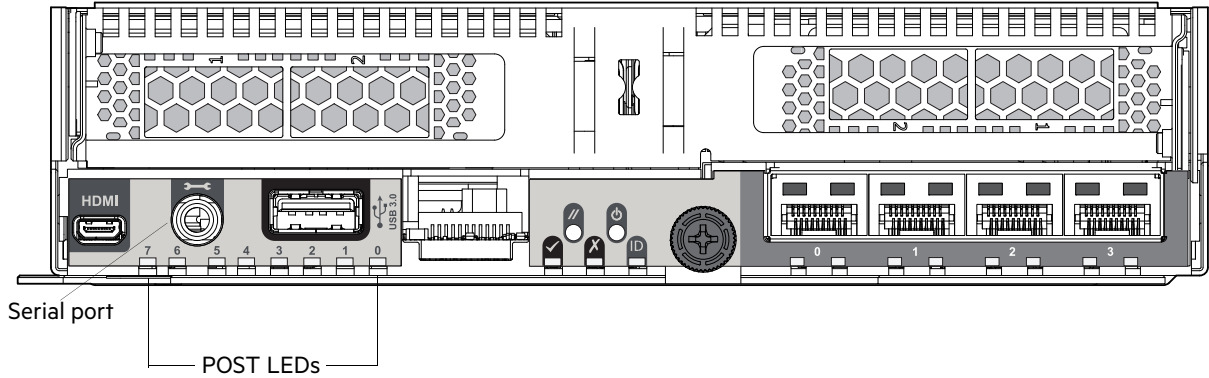

Figure 100 BIOS phase indication mediums

The values for each LED are given in the following table:

Table 19 POST LED Bit values

LED Number	0	1	2	3	4	5	6	7
Value	1	2	4	8	16	32	64	128
Example	So, if LEDs 0, 2, 3, 4, 5 and 6 are lit, this equates to: $1 + 4 + 8 + 16 + 32 + 64 = 125$ or $0x7D$ in hex.							

List of POST Codes

SEC Phase

SEC phase stands for Security phase. SEC phase begins when the system (to be precise - CPU present in the controller) is reset or powered on. The system remains in SEC phase from this point until the time when temporary RAM is available.

Table 20 Sec Phase POST codes

POST Code	Definition
0x01	CPU power on and switch to Protected mode
0x02	Patching CPU microcode
0x03	Setup Cache as RAM
0x04	PCIE MMIO Base Address initial
0x05	CPU Generic MSR initial
0x06	Setup CPU speed
0x07	Cache as RAM test
0x08	Tune CPU frequency ratio to maximum level
0x09	Setup BIOS ROM cache
0x0A	Enter Boot Firmware Volume

PEI Phase

The PEI (Pre-EFI Initialization) phase is the phase when the system goes from temporary RAM till the time it finds permanent RAM. It also determines Boot mode.

The Pre-EFI Initialization (PEI) phase provides a standardized method of loading and invoking specific initial configuration routines for the processor, chipset, and motherboard. The PEI phase occurs after the Security (SEC) phase. The primary purpose of code operating in this phase is to initialize enough of the system to allow instantiation of the Driver Execution Environment (DXE) phase.

At a minimum, the PEI phase is responsible for three items:

1. Determine the Boot Mode
2. Initialize system memory
3. Expose the Firmware Volume that contains the DXE Foundation

Table 21 PEI phase POST codes

POST Code	Definition
0x70	Super I/O initial
0x71	CPU Early Initial
0x77	PCIE Training
0x72	Multi-processor Early initial
0x73	Hyper Transport initial
0x74	PCIE MMIO BAR Initial
0x75	North Bridge Early Initial
0x76	South Bridge Early Initial
0x78	TPM Initial
0x79	SMBUS Early Initial
0x7A	Clock Generator Initial
0x7B	Internal Graphic device early initial, PEI_IGDOPRegion
0x7C	HECI Initial
0x7D	Watchdog timer initial
0x7E	Memory Initial for Normal boot.
0x7F	Memory Initial for Crisis Recovery
0x80	Simple Memory test
0x81	TXT function early initial
0x82	Start to use Memory
0x83	Set cache for physical memory
0x84	Recovery device initial
0x85	Found Recovery image
0x86	Recovery image not found
0x87	Load Recovery Image complete
0x88	Start Flash BIOS with Recovery image
0x89	Loading BIOS image to RAM
0x8A	Loading DXE core
0x8B	Enter DXE core

POST Code	Definition
0x8C	iFFS Transition Start
0x8D	iFFS Transition End

DXE Phase

In DXE (Driver Execution Environment) phase, the system travels from a stage where permanent memory is available to the stage where firmware is ready to look for a boot device.

The Driver Execution Environment (DXE) phase contains an implementation of UEFI that is compliant with the UEFI 2.0+ Specification. As a result, both the DXE Foundation and DXE drivers share many of the attributes of UEFI images. The DXE phase is the phase where most of the system initialization is performed. The Pre-EFI Initialization (PEI) phase is responsible for initializing permanent memory in the platform so the DXE phase can be loaded and executed. The state of the system at the end of the PEI phase is passed to the DXE phase through a list of position-independent data structures called Hand-Off Blocks (HOBs).

Table 22 DXE phase POST codes

POST Code	Definition
0x40	TPM initial in DXE
0x41	South bridge SPI initial
0x42	Setup Reset service, DXE_CF9Reset
0x43	South bridge Serial GPIO initial, DXE_SB_SerialGPIO_INIT
0x44	Setup SMM ACCESS service
0x45	North bridge Middle initial
0x46	Super I/O DXE initial
0x47	Setup Legacy Region service, DXE_LegacyRegion
0x48	South Bridge Middle Initial
0x49	Identify Flash device
0x4A	Fault Tolerant Write verification
0x4B	Variable Service Initial
0x4C	Fail to initial Variable Service
0x4D	MTC Initial
0x4E	CPU Middle Initial
0x4F	Multi-processor Middle Initial
0x50	SMBUS Driver Initial
0x51	8259 Initial
0x52	RTC Initial
0x53	SATA Controller early initial
0x54	Setup SMM Control service, DXE_SMMControler_INIT
0x55	Setup Legacy Interrupt service, DXE_LegacyInterrupt
0x56	Relocate SMM BASE
0x57	SMI test
0x58	VTD Initial
0x59	Legacy BIOS initial
0x5A	Legacy interrupt function initial

POST Code	Definition
0x5B	ACPI Table Initial
0x5C	Setup SB SMM Dispatcher service, DXE_SB_Dispatch
0x5D	Setup SB IOTRAP Service
0x5E	Build AMT Table
0x5F	PPM Initial
0x60	HECIDRV Initial
0x61	Variable store garbage collection and reclaim operation
0x62	Do not support flash part (which is defined in SpiDevice.c)

BDS Phase

BDS (Boot Device Selection) phase, as the name suggests, is the phase in which boot device is selected and it is booted.

Table 23 BDS phase POST codes

POST Code	Definition
0x10	Enter BDS entry
0x11	Install Hotkey service
0x12	ASF Initial
0x13	PCI enumeration
0x14	PCI resource assign complete
0x15	PCI enumeration complete
0x16	Keyboard Controller, Keyboard and Mouse initial
0x17	Video device initial
0x18	Error report device initial
0x19	USB host controller initial
0x1A	USB BUS driver initial
0x1B	USB device driver initial
0x1C	Console device initial fail
0x1D	Display logo or system information
0x1E	IDE controller initial
0x1F	SATA controller initial
0x20	SIO controller initial
0x21	ISA BUS driver initial
0x22	Floppy device initial
0x23	Serial device initial
0x24	IDE device initial
0x25	AHCI device initial
0x26	Dispatch option ROMs
0x27	Get boot device information
0x28	End of boot selection
0x29	Enter Setup Menu

POST Code	Definition
0x2A	Enter Boot manager
0x2B	Try to boot system to OS
0x2C	Shadow Misc Option ROM
0x2D	Save S3 resume required data in RAM
0x2E	Last Chipset initial before boot to OS
0x2F	Start to boot Legacy OS
0x30	Start to boot UEFI OS
0x31	Prepare to Boot to Legacy OS
0x32	Send END of POST Message to ME via HECI
0x33	Last Chipset initial before boot to Legacy OS
0x34	Ready to Boot Legacy OS.
0x35	Fast recovery start flash
0x36	SDHC device initial
0x37	Ata Legacy device initial
0x38	SD Legacy device initial
0x39	Enter firmware UI
0x3A	Perform Platform-Defined boot option recovery
0x3B	Perform OS-Defined boot option recovery
0x3C	Perform system preparation applications

Post BDS Phase

System enters this phase once BDS phase is over. Refer the table below to understand processing of the system.

Table 24 Post BDS phase POST codes

POST Code	Definition
0xF9	No Boot Device, PostBDS_NO_BOOT_DEVICE
0xFB	UEFI Boot Start Image, PostBDS_START_IMAGE
0xFD	Legacy 16 boot entry
0xFE	Try to Boot with INT 19

SMM Phase

SMM (System Management Mode) phase is a phase in which a system enters when SMI (System Management Interface) is triggered. Unlike rest of the 4U100 enclosure phases, this phase does not occur in sequence.

Table 25 SMM phase POST codes

POST Code	Definition
0xA0	Identify Flash device in SMM
0xA2	SMM service initial
0xA6	OS call ACPI enable function
0xA7	ACPI enable function complete
0xA1	Enter S1
0xA3	Enter S3

POST Code	Definition
0xA4	Enter S4
0xA5	Enter S5
0xA8	OS call ACPI disable function
0xA9	ACPI disable function complete

ASL Functionality

System enters into ASL (ACPI Source Language) functionality when the system wants to communicate with the Operating System. Similar to SMM phase, this functionality is not in sequence with previous 4U100 enclosure BIOS phases.

Table 26 ASL Functionality POST codes

POST Code	Definition
0x51	Prepare to enter S1
0x53	Prepare to enter S3
0x54	Prepare to enter S4
0x55	Prepare to enter S5
0xE1	System wakeup from S1
0xE3	System wakeup from S3
0xE4	System wakeup from S4
0xE5	System wakeup from S5

Intel Reference Code POST Code

Memory RC POST Code

Table 27 Memory RC POST codes

POST Code	Definition
0xB0	DIMM Detect
0xB1	Clock Initial
0xB2	SPD Data
0xB3	Global Early Initial
0xB4	Rank Detect
0xB5	Channel Early Initial
0xB6	DDR IO Early Initial
0xB7	Channel Training
0xB8	Initialize Throttling
0xB9	MEM BIST
0xBA	MEM Initial
0xBB	DDR Memory Map
0xBC	RAS Config
0xBD	Get Margins (Calculates positive and negative margin for the group provided)

POST Code	Definition
0xBE	SSA API INIT
0xBF	MRC Done

KIT RC POST Code

Table 28 KIT RC POST codes

POST Code	Definition
0xA0	Initialize KTI input structure default values
0xA1	Collect info such as SBSP, Boot Mode, Reset type etc
0xA3	Setup up minimum path between SBSP & other sockets
0xA6	Sync up with PBSPs
0xA7	Topology discovery and route calculation
0xA8	Program final route
0xA9	Program final IO SAD setting
0xAA	Protocol layer and other Uncore settings
0xAB	Transition links to full speed operation
0xAE	Coherency Settings
0xAF	KTI is done

IIO RC POST Code

Table 29 IIO RC POST code

POST Code	Definition
0xE0	IIO early init entry
0xE1	Early Pre-link training setting
0xE2	IIO Gen3 EQ programming
0xE3	IIO Link training
0xE4	IIO Gen3 override
0xE5	IIO early init exit
0xE6	IIO late init entry
0xE7	PCIE port init
0xE8	IOAPIC init
0xE9	VTD init
0xEA	IOAT init
0xEB	IIO DFX init
0xEC	NTB init
0xED	Security init
0xEE	IIO late init exit
0xEF	IIO On ready to boot

System BOOT POST Code flow sample

Cold Boot Flow

Table 30 Cold Boot flow sample

POST Code	Definition
70	Super I/O initial
74	PCIE MMIO BAR Initial
76	South Bridge Early Initial
A1	Collect info such as SBSP, Boot Mode, Reset type etc.
A3	Setup up minimum path between SBSP & other sockets
A7	Topology discovery and route calculation
A9	Program final IO SAD setting
AA	Protocol layer and other Uncore settings
AB	Transition links to full speed operation
AF	KTI is done
B0	DIMM Detect
B1	Clock Initial
AF	KTI is done, ready to reset
System Reboot	
70	Super I/O initial
74	PCIE MMIO BAR Initial
76	South Bridge Early Initial
A1	Collect info such as SBSP, Boot Mode, Reset type etc.
A3	Setup up minimum path between SBSP & other sockets
A7	Topology discovery and route calculation
A8	Program final route
A9	Program final IO SAD setting
AA	Protocol layer and other Uncore settings
AE	Coherency Settings
AF	KTI is done
E0	IIO early init entry
E1	Early Pre-link training setting
E4	IIO Gen3 override
E3	IIO Link training
E5	IIO early init exit
B0	DIMM Detect
B1	Clock Initial
B4	Rank Detect
B2	SPD Data
B3	Global Early Initial
B6	DDR IO Early Initial

POST Code	Definition
B7	Channel Training
BE	SSA API INIT
B7	Channel Training
B8	Initialize Throttling
B9	MEM BIST
BA	MEM Initial
B9	MEM BIST
BB	DDR Memory Map
B7	Channel Training
BC	RAS Config
BF	MRC Done
E6	IIO late init entry
E7	PCIE port init
E8	IOAPIC init
E9	VTD init
EB	IIO DFX init
EC	NTB init
ED	Security init
EE	IIO late init exit
83	Set cache for physical memory
41	South bridge SPI initial
4B	Variable Service Initial
52	RTC Initial
4D	MTC Initial
41	South bridge SPI initial
59	Legacy BIOS initial
41	South bridge SPI initial
A2	SMM service initial
41	South bridge SPI initial
5A	Legacy interrupt function initial
10	Enter BDS entry
41	South bridge SPI initial
11	Install Hotkey service
12	ASF Initial
13	PCI enumeration
15	PCI enumeration complete
1A	USB BUS driver initial
1B	USB device driver initial
16	Keyboard Controller, Keyboard and Mouse initial
20	SIO controller initial

POST Code	Definition
17	Video device initial
18	Error report device initial
1D	Display logo or system information
26	Dispatch option ROMs
27	Get boot device information
28	End of boot selection
2B	Try to boot system to OS
3C	Perform system preparation applications
2E	Last Chipset initial before boot to OS
30	Start to boot UEFI OS
FB	UEFI Boot Start Image, PostBDS_START_IMAGE

Warm Boot Flow

Table 31 Warm Boot flow sample

POST Code	Definition
70	Super I/O initial
74	PCIE MMIO BAR Initial
76	South Bridge Early Initial
A1	Collect info such as SBSP, Boot Mode, Reset type etc.
A3	Setup up minimum path between SBSP & other sockets
A7	Topology discovery and route calculation
A9	Program final IO SAD setting
A8	Program final route
A9	Program final IO SAD setting
AA	Protocol layer and other Uncore settings
AE	Coherency Settings
AF	KTI is done
E0	IIO early init entry
E1	Early Pre-link training setting
E4	IIO Gen3 override
E3	IIO Link training
E5	IIO early init exit
B0	DIMM Detect
B1	Clock Initial
B4	Rank Detect
B2	SPD Data
B3	Global Early Initial
B6	DDR IO Early Initial
B7	Channel Training
BE	SSA API INIT

POST Code	Definition
B7	Channel Training
B8	Initialize Throttling
B9	MEM BIST
BA	MEM Initial
BB	DDR Memory Map
B7	Channel Training
BC	RAS Config
BF	MRC Done
E6	IIO late init entry
E7	PCIE port init
E8	IOAPIC init
E9	VTD init
EB	IIO DFX init
EC	NTB init
ED	Security init
EE	IIO late init exit
83	Set cache for physical memory
41	South bridge SPI initial
4B	Variable Service Initial
52	RTC Initial
4D	MTC Initial
41	South bridge SPI initial
59	Legacy BIOS initial
A2	SMM service initial
5A	Legacy interrupt function initial
10	Enter BDS entry
11	Install Hotkey service
12	ASF Initial
13	PCI enumeration
15	PCI enumeration complete
1A	USB BUS driver initial
1B	USB device driver initial
16	Keyboard Controller, Keyboard and Mouse initial
20	SIO controller initial
17	Video device initial
18	Error report device initial
1D	Display logo or system information
26	Dispatch option ROMs
27	Get boot device information
28	End of boot selection

POST Code	Definition
2B	Try to boot system to OS
3C	Perform system preparation applications
2E	Last Chipset initial before boot to OS
30	Start to boot UEFI OS
FB	UEFI Boot Start Image, PostBDS_START_IMAGE

Index

Numerics

- 4U
 - 4 EAI units 14
 - 4U100 14, 19

A

- audience 14

C

- CFF
 - Common Form Factor 14
- CMA
 - Cable Management Arm 69
- connecting
 - power cord (PDU to PSU) 79
- CRUs
 - AP-RH-1 Controller 24
 - Controller Channel fan 42
 - drive module 38
 - HS Expander 44
 - PSU 25
 - system fan 26

D

- disk modules
 - dual path LFF 39
- document
 - conventions and symbols 14
 - prerequisite knowledge 14

E

- electrostatic discharge
 - grounding methods 90
 - precautions 89
- enclosure
 - dust-free operating environment 35
 - system airflow 35

F

- fault isolation methodology 85

H

- hosts
 - stopping I/O 107

I

- installation checklist 45

L

- LEDs
 - front panel

- enclosure LEDs 32
- rear panel
 - PSU 33
 - system fan 34
- top panel
 - HS Expander 44

P

- Product name
 - Exos E 4U100 14

R

- rackmount rail kit
 - safety precautions 18

S

- safety precautions
 - electrical safety 17
 - rack system safety 18
 - safe handling 16, 89
 - safe operation 16

T

- technical specifications
 - enclosure dimensions 112
 - enclosure weights 112
 - environmental requirements 113
 - power and cooling 114