



SEAGATE

Exos[®] E 2U12, 2U24, 5U84 Series Hardware Installation and Maintenance Guide

Abstract

This guide describes initial hardware setup for Seagate Exos E 2U12, 2U24, 5U84 Series controller enclosures and disk enclosures. It also describes removal and installation of customer-replaceable components. The guide is intended for use by storage system administrators familiar with servers and computer networks, network administration, storage system administration and configurations, storage area network management, and relevant protocols.

Part Number: 204380800-00

Revision: A

Published: December 2022

© 2022 Seagate Technology LLC or its affiliates. All rights reserved. Seagate, Seagate Technology, and the Spiral logo are registered trademarks of Seagate Technology LLC in the United States and/or other countries. Exos is a trademark of Seagate Technology LLC or one of its affiliated companies in the United States and/or other countries. All other trademarks or registered trademarks are the property of their respective owners. When referring to disk capacity, one gigabyte (GB) equals one billion bytes, one terabyte (TB) equals one trillion bytes, and one petabyte (PB) equals one thousand terabytes. Your computer's operating system may use a different standard of measurement and report a lower capacity. In addition, some of the listed capacity is used for formatting and other functions, and thus will not be available for data storage. All coded instruction and program statements contained herein remain copyrighted works and confidential proprietary and trade secret information of Seagate Technology LLC or its affiliates. Any use, derivation, disassembly, reverse engineering, dissemination, reproduction, or any attempt to modify, prepare derivative works, reproduce, distribute, disclose copyrighted material of Seagate Technology LLC, for any reason, in any manner, medium, or form, in whole or in part, if not expressly authorized, is strictly prohibited. Seagate reserves the right to change, without notice, product offerings or specifications.

Regulatory and compliance information

For the latest regulatory and compliance information see www.seagate.com/support/data-storage-systems/. Scroll down to the Compliance, Safety and Disposal Guide link.

Contents

1 Introduction	8
Knowledge prerequisites	8
Product documentation and support	8
Intended audience	9
2 System overview	10
Expansion enclosure components	10
Expansion enclosure chassis	11
2U enclosure components	11
5U enclosure components	13
Optional components	16
3 Initial install preparations	18
Installation checklist	18
Complete installation prerequisites	19
4 Installation of 2U enclosures	21
Unpack and prepare the 2U enclosure	21
Install the 2U rackmount rail kit	22
Mount the 2U enclosure into the rack cabinet	25
Populate the 2U enclosure	27
Test enclosure electrical earth connection	28
Route 2U enclosure data cables and power cords	28
Route 2U enclosure host cables and expansion data cables	29
Route 2U enclosure power cords	30
5 Installation of 5U enclosures	32
Unpack and prepare the 5U enclosure	32
Install the 5U rackmount rail kit	33
Mount the 5U enclosure into the rack cabinet	37
Access a drawer	40
Populate the 5U enclosure	41
Test enclosure electrical earth connection	42
Route 5U enclosure data cables and power cords	42
Route 5U enclosure host cables and expansion data cables	43
Route 5U enclosure power cords	44
6 Operation of 2U enclosures	46
Apply power to the 2U enclosure	46
Remove power from the 2U enclosure	47
Set the unit identification number	47

Interpret system LEDs	47
Interpret 2U12 and 2U24 operator's panel LEDs	48
Interpret SAS 12Gb/s expansion input/output module LEDs	49
7 Operation of 5U enclosures	51
Apply power to the 5U enclosure	51
Remove power from the 5U enclosure	52
Set the unit identification number	52
Interpret system LEDs	52
Interpret 5U enclosure operator's panel LEDs	53
Interpret drawer LED panels	54
Interpret SAS 12Gb/s expansion input/output module LEDs	55
8 Hardware installation and configuration issues	57
Address initial start-up issues	57
Interpret storage and expansion enclosure fault LEDs	58
2U12 and 2U24 enclosure fault LEDs	58
5U84 enclosure fault LEDs	60
Identify 2U enclosure fault conditions	65
Identify 5U enclosure fault conditions	65
Isolate hardware and connectivity faults	66
Isolate system application faults	67
Take corrective action for 2U enclosures	68
Take corrective action for 5U enclosures	69
9 In-service field maintenance for 2U enclosures	73
Replace a 2U enclosure drive module in its carrier	74
Replace a 2U enclosure input/output module	76
Replace a 2U power cooling module	78
10 In-service field maintenance for 5U enclosures	82
Replace a 5U enclosure drive module in its carrier	83
Replace a 5U enclosure input/output module	87
Replace a 5U fan cooling module	90
Replace a 5U power supply unit	91
A Technical specifications	95
B Standards and regulations	97
International standards	97
WEEE recycling	97
Index	98

Figures

Figure 1	2U12 and 2U24 front panel area	12
Figure 2	2U12 and 2U24 rear panel area	13
Figure 3	5U84 front panel area	14
Figure 4	5U84 rear panel area	15
Figure 5	Profile and top views of fully populated 5U84 drawers	16
Figure 6	2U12 and 2U24 expansion enclosure packaging, shown without plastic for clarity	21
Figure 7	2U enclosure outer rail components	23
Figure 8	Attachment of front mount bracket to front rack cabinet posts	24
Figure 9	Adjustment of rail length to fit rack cabinet	24
Figure 10	Attachment of rear mount bracket to rear rack cabinet posts	25
Figure 11	Alignment between 2U chassis and rails (removed rear components for clarity)	26
Figure 12	Installation of 2U rear screw to secure chassis to rail	27
Figure 13	Sample reverse cabling method among the host system and 2U expansion modules	30
Figure 14	Sample invalid loop (in red) among the host system and 2U expansion modules	30
Figure 15	2U power cord routing to independent power distribution units	31
Figure 16	Default belt straps already around the 5U expansion enclosure	32
Figure 17	5U left and right rail components	35
Figure 18	Insertion of 5U front mount bracket screw	36
Figure 19	Insertion of 5U rear mount bracket screws	36
Figure 20	Alignment between 5U chassis and rails, minus rear components for clarity	38
Figure 21	Secure chassis operator's panel to rack posts	39
Figure 22	5U rear chassis connection to outer rails, detail, minus rear components for clarity	39
Figure 23	Safety lock to release left drawer slide rail (lower drawer used for relational clarity)	40
Figure 24	Carrier latch features	41
Figure 25	Release latch open and unlocked	41
Figure 26	Release latch properly locked	41
Figure 27	Sample reverse cabling method among the 5U host system and expansion modules	44
Figure 28	Sample invalid loop (in red) among the 5U host system and expansion modules	44
Figure 29	5U power cord routing to independent power distribution units	45
Figure 30	2U12 and 2U24 operator's panel LEDs	49
Figure 31	SAS 12Gb/s expansion input/output module LEDs	50
Figure 32	5U84 operator's panel LEDs	54
Figure 33	5U84 drawer LED panel	55
Figure 34	SAS 12Gb/s expansion input/output module LEDs	56
Figure 35	2U12 and 2U24 operator's panel fault LEDs	58
Figure 36	2U12 and 2U24 fault LEDs on carrier bezel	59
Figure 37	SAS 12Gb/s expansion module fault LEDs	59
Figure 38	Power cooling module fault LEDs	60

Figure 39	5U84 operator's panel fault LEDs	61
Figure 40	5U84 drawer fault LEDs on drawer LED panel	62
Figure 41	Drive fault LED on carrier bezel	62
Figure 42	SAS 12GB expansion module fault LEDs	63
Figure 43	Fan cooling module fault LEDs	64
Figure 44	Power supply unit fault LEDs	64
Figure 45	2U12 and 2U24 fault LEDs on carrier bezel	74
Figure 46	Removal of 2U12 and 2U24 drive in carrier	75
Figure 47	Replacement with open 2U12 and 2U24 carrier handle	76
Figure 48	SAS 12Gb/s expansion input/output module LEDs	77
Figure 49	Input/output module removal, upper	78
Figure 50	Replacement input/output module	78
Figure 51	Power cooling module removal	80
Figure 52	Replacement power cooling module	80
Figure 53	Drive fault LED on carrier bezel	83
Figure 54	Operator's panel	84
Figure 55	Drawer panel	84
Figure 56	Drawer release and access	84
Figure 57	Carrier latch features	85
Figure 58	Removal of drive in its carrier	85
Figure 59	Replacement of drive in its carrier	86
Figure 60	Release latch open and unlocked	86
Figure 61	Release latch properly locked	86
Figure 62	Safety lock to release left drawer slide rail of lower drawer	87
Figure 63	SAS 8Gb/s input/output module LEDs	88
Figure 64	Input/output module removal, left	89
Figure 65	Replacement input/output module	89
Figure 66	Fan cooling module fault LEDs	90
Figure 67	Fan cooling module removal	91
Figure 68	Replacement fan cooling module	91
Figure 69	Power supply unit fault LEDs	92
Figure 70	Power supply unit removal	93
Figure 71	Replacement power supply unit	93

Tables

Table 1	Expansion enclosure variations	10
Table 2	Installation checklist tasks	18
Table 3	Fault LED prioritization	48
Table 4	Fault LED prioritization	53
Table 5	2U enclosure non-fault conditions	65
Table 6	5U enclosure non-fault conditions	66
Table 7	2U enclosure corrective action for fault conditions	68
Table 8	5U enclosure corrective action for fault conditions	69
Table 9	2U enclosure time limits for FRU replacement	73
Table 10	5U enclosure time limits for FRU replacement	82
Table 11	Expansion enclosure dimensions	95
Table 12	Expansion enclosure FRU weights	95
Table 13	Environmental specifications	95
Table 14	Power specifications	96
Table 15	Standard and approvals	97

1 Introduction

Seagate Exos E expansion enclosures combine strong performance with high reliability, flexibility, and manageability. Powerful and compact, the series expandable storage solution supports business with high-capacity and high-availability options.

The system is designed for high availability (HA), with no single point of failure for data or power. Input/output modules (IOMs) are Storage Bridge Bay (SBB) v2.1 compatible for interconnects, power budgets and rails, form factors, and footprints.

⚠ WARNING! Heed all warnings and cautions on labeling and throughout this guide to reduce risk of personal injury or damage to equipment. You must adhere to all safety requirements in this document. Some relate to the entire system, some to the rack, some to the storage or expansion enclosure, and others to the FRUs within it.



Knowledge prerequisites

Make sure you have the appropriate knowledge base prior to product installation or service.

- Server system administration
- Storage system configuration
- Storage area network (SAN) management
- Fibre Channel (FC) protocol
- Serial Attached SCSI (SAS) protocol
- Ethernet protocol

Product documentation and support

To obtain documentation, videos, and product information, visit www.seagate.com/support/data-storage-systems/.

Content description	Document	Seagate QR codes
Enhancements, known issues, and updates	Release Notes	Documentation, Support 
Installation of the rail kit and enclosure into a rack	Rackmount Guide*	
Initial installation of hardware and component replacement	Hardware Installation and Maintenance Guide	
Regulatory compliance, safety, and disposal information	Compliance, Safety, and Disposal Guide	5U documentation, support
*Printed document included in the shipkit		

Intended audience

This guide is for software integration providers, storage installation professionals, and system administration personnel.

2 System overview

The Seagate Exos E expansion series enclosures consist of a sheet metal chassis that contains an integrated midplane and module runner system. You can mount the expansion enclosure into a standard 19-inch rack cabinet, occupying either two (2U) or five (5U) EIA rack space units. All plug-in modules are hot-swappable, but you must adhere to all safety precautions and time limitations.

Table 1 Expansion enclosure variations

Type	Typical set of plug-in modules	Maximum expansions
2U12 expansion enclosure	2U chassis and rackmount railkit	Up to 12
	12 3.5-inch large form factor (LFF) drive modules in carriers (DDICs)	
	Two input/output modules (IOMs)	
	Two power cooling modules (PCMs)	
2U24 expansion enclosure	2U chassis and rackmount railkit	Up to 6
	24 2.5-inch small form factor (SFF) DDICs	
	Two input/output modules (IOMs)	
	Two power cooling modules (PCMs)	
5U84 expansion enclosure	5U chassis and rackmount railkit: Contains two drawers, each with 42 drive modules	Up to 4
	84 3.5-inch or 2.5-inch drive modules with adapters in carriers	
	Two input/output modules (IOMs)	
	Five fan cooling modules (FCMs)	
	Two power supply units (PSUs)	
	Four sideplane printed circuit boards (PCBs), two per drawer <i>Authorized service personnel only</i>	

Expansion enclosures can be configured as either an EBOD or a JBOD. An EBOD is an expansion enclosure attached to a controller enclosure (RBOD). A JBOD is an expansion enclosure attached directly to a server that is equipped with a SAS HBA or SAS RAID adapter.

 **CAUTION** Make sure you are not connected to power at any time during installation procedures.

 **CAUTION** Only operate the expansion enclosure in a dust-free environment to meet temperature control and airflow requirements.

Expansion enclosure components

All Seagate Exos E expansion enclosures have 2 main access points:

1. **Front panel area** — Contains the operator's (ops) panel and access to drive modules in their carriers (DDICs)
 - a. **2U enclosures** — Direct access to DDICs
 - b. **5U enclosures** — Access to DDICs by opening the related drawer
2. **Rear panel area** — Contains input/output modules and methods for cooling and powering the expansion enclosure

Expansion enclosure chassis

Chassis sheet metal is bonded and riveted together and free from non-conductive coatings. Each chassis is designed specifically for mounting in a rack cabinet.

2U enclosure components

The front panel area hosts an operator's panel and the drive modules.

- **2U12**— Contains 3.5-inch large form factor (LFF) drives installed in keyed carriers, inserted into horizontal slots, and logically numbered in rows from 0 to 11 from left to right, from top to bottom
- **2U24**— Contains 2.5-inch small form factor (SFF) drives installed in keyed carriers, inserted into vertical slots, and logically numbered from 0 to 23 from left to right

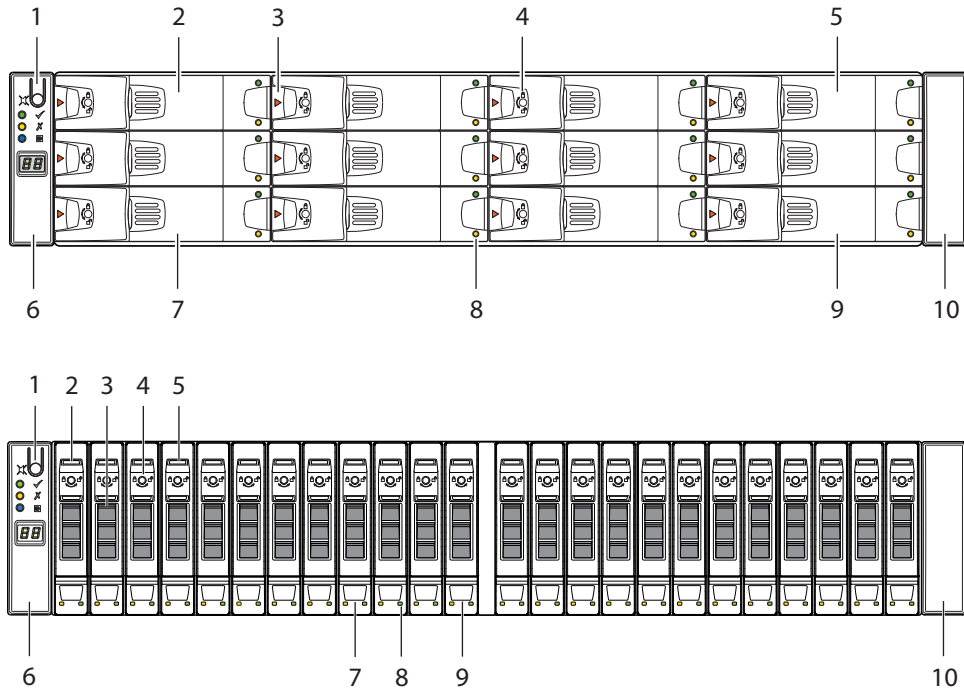

Item	Description	Function
1	Input button	Selects and sets UID when combined with system Locate command
2	Drive 0	Responds to commands for drive logically numbered "0"
3	Release latch, drive module	Allows drive module insertion onto and removal from the midplane and slot
4	Anti-tamper lock, drive module	Prevents drive module removal when locked
5	Drive 3	Responds to commands for drive logically numbered "3"
6	Operator's (ops) panel on left rack ear flange	Connects to midplane, provides users with expansion enclosure information and status
7	Drive 8	Responds to commands for drive logically numbered "8"
8	Status LEDs, drive module	Provides users with drive module status
9	Drive 11	Responds to commands for drive logically numbered "11"
10	Right rack ear cover	Acts as cosmetic cover over rack flange

Figure 1 2U12 and 2U24 front panel area

The rear panel area hosts modules designed for power, thermal cooling, and host connectivity.

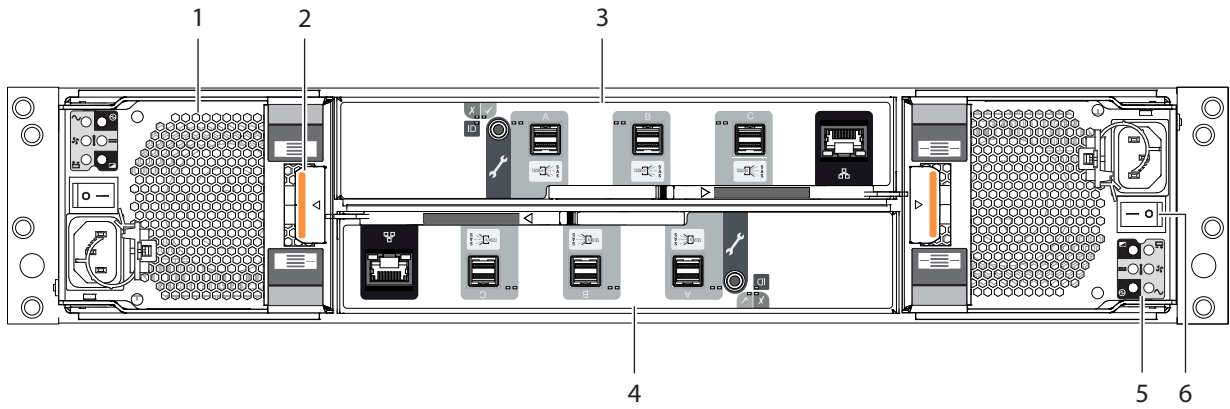

Item	Description	Function
1	Power cooling module (PCM)	Provides redundant regulation of power, temperature, and airflow
2	PCM release latch	Latches or unlatches PCM from midplane
3	Input/output module (IOM)	Provides data redundancy, acts as the nerve center of the expansion enclosure
4	Inverted IOM	
5	Inverted PCM status LEDs	Provides users with PCM status
6	Inverted PCM power switch	Switches power on or off

Figure 2 2U12 and 2U24 rear panel area

5U enclosure components

The 5U84 chassis retains two sliding drawers, so has drawer panels that augment the operator's (ops) panel on the left rack ear flange. Each drawer has its own set of dedicated connectors behind the midplane that allow continuous operation, even if the drawer is extended to the fully open service position or closed with the drawer latch engaged.

The front panel area is the primary physical user interface. Closely watch the ops and drawer panels for status.

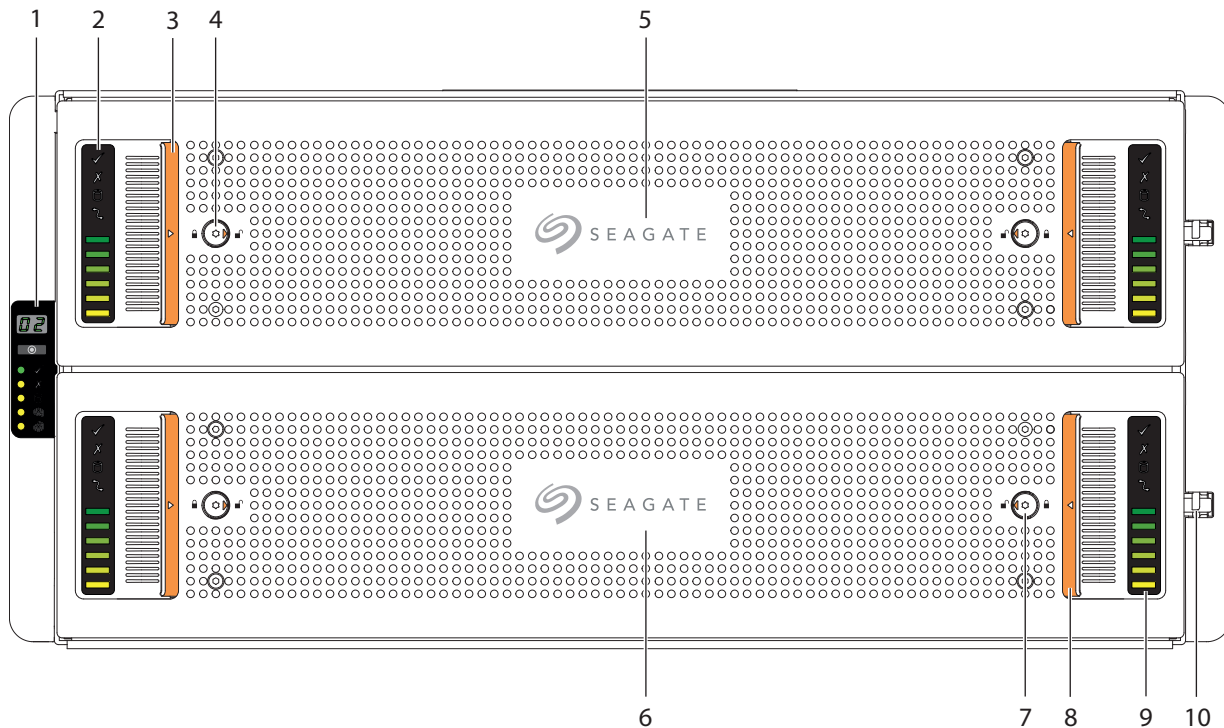

Item	Description	Function
1	Operator's (ops) panel	Connects to midplane, provides users with expansion enclosure information and status
2	Drawer left sideplane indicators	Registers activity for the related drive in its carrier (DDIC) and controller for the drawer's left sideplane
3	Left pull handle in recessed pocket	Provides user access to DDICs contained in drawer
4	Drawer left side anti-tamper lock	Prevents drawer access when locked
5	Top drawer: Drawer 1	Contains DDIC slots logically numbered from 0 to 41
6	Bottom drawer: Drawer 2	Contains DDIC slots logically numbered from 42 to 83
7	Drawer right side anti-tamper lock	Prevents drawer access when locked
8	Right pull handle in recessed pocket	Provides user access to DDICs within the drawer
9	Drawer right sideplane indicators	Registers activity for the related DDIC and controller for the drawer's right sideplane
10	Drawer latch	Latches the drawer closed when properly engaged

Figure 3 5U84 front panel area

The rear panel area provides you access to modules designed for power, thermal cooling, and host connectivity.

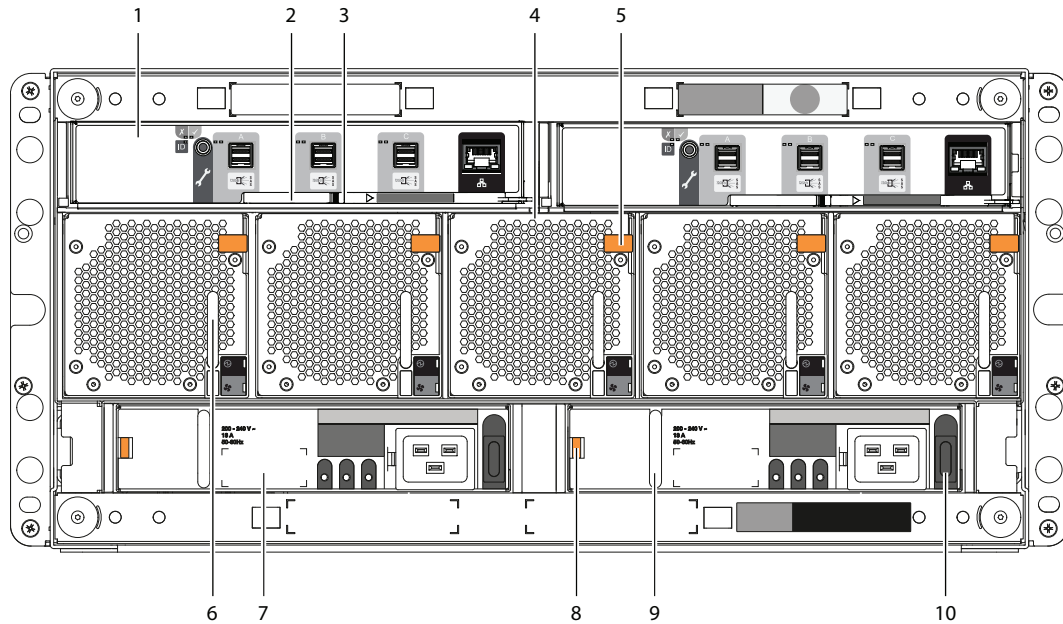

Item	Description	Function
1	Input/output module (IOM)	Provides data redundancy and is the nerve center of the expansion enclosure
2	IOM release latch	Provides full contact with midplane or releases IOM for inspection and service
3	IOM release latch and handle	
4	Fan cooling module (FCM)	Provides redundant regulation of temperature and airflow
5	FCM release latch	Provides full contact with midplane or releases FCM for inspection and service
6	FCM pull handle	
7	Power supply unit (PSU)	Provides redundant regulation of power
8	PSU release latch	Provides full contact with midplane or releases PSU for inspection and service
9	PSU pull handle	
10	PSU power switch	Powers on or off the expansion enclosure

Figure 4 5U84 rear panel area

Two sliding drawers hold DDICs and their related sideplanes.

- **Two drawers** each can contain 42 DDICs. Drawer slides lock the drawer in the fully open service position, so require release latch activation to close the drawer.
- **DDICs** slide into 42 slots in each drawer. The upper drawer, Drawer 1, contains slots logically numbered from 0 to 41 in rows moving from top to bottom, then from left to right. The lower drawer, Drawer 2, contains slots logically numbered from 42 to 83, following the same pattern.

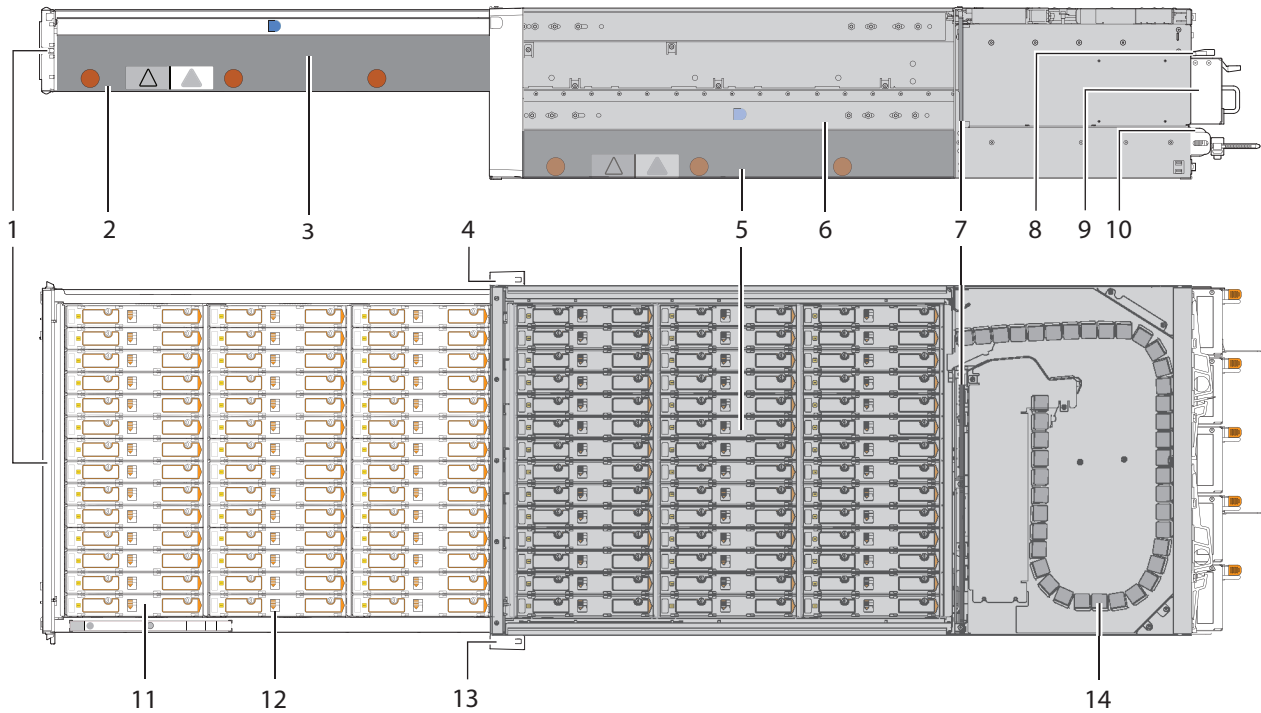

Item	Description	Function
1	Drawer front with keyed anti-tamper lock and 2 drawer latches	Prevents or provides access to DDICs, contains dual drawer panel LEDs for drive activity and fault status
2	Right sideplane	Registers DDIC activity and fault conditions for the primary host path
3	Top drawer: Drawer 1	Contains slots logically numbered from 0 to 41
4	Operator's (ops) panel on left rack ear flange	Connects to midplane, provides users with expansion enclosure information and status
5	Bottom drawer: Drawer 2	Contains slots logically numbered from 42 to 83
6	Drawer slide	Supports full extension to service position and access to DDICs
7	Midplane	Connects modules to system controls (<i>Authorized service personnel only</i>)
8	Input/output module (IOM)	Provides data redundancy and acts as the nerve center of the expansion enclosure
9	Fan cooling module (FCM)	Provides redundant regulation of temperature and airflow
10	Power supply unit (PSU)	Provides redundant regulation of power
11	Drive module in its carrier (DDIC)	Provides redundant data storage
12	Locking mechanism	Secures full connection of DDIC
13	Right rack ear cover	Cosmetic
14	Cable management system	Protects cabling associated with the related drawer

Figure 5 Profile and top views of fully populated 5U84 drawers

Optional components

Occasionally, you may configure the expansion enclosure to operate without all of its components. The most common reason is to perform in-field maintenance. Temperature and airflow requirements for 2U enclosures mandate you immediately use blanks to replace modules you remove and adhere to all specified time limitations for replacement.

- **Carrier blank**— For 2U enclosures not fully populated, occupies any empty drive slot to secure proper airflow
- **Controller blank**— For 2U enclosures configured with a single controller, occupies the empty controller slot to secure proper airflow

3 Initial install preparations

Each expansion enclosure installation requires the same amount of preparation to successfully mount it into your industry-standard rack cabinet of up to 1.2m in depth.

⚠ WARNING! Heed all warnings and cautions on labeling and throughout this guide to reduce risk of personal injury or damage to equipment. You must adhere to all safety requirements in this document. Some relate to the entire system, some to the rack, some to the storage or expansion enclosure, and others to the FRUs within it.

⚠ CAUTION Use only power cords supplied in the installation kit or those that meet product specifications.

ⓘ IMPORTANT Only a qualified service technician should perform the installation.

Installation checklist

Read this entire section before you begin. You must adhere to all safety requirements prior to and during installation.

⚠ WARNING! Do not attempt to install the 5U expansion enclosure into the rack cabinet with drive modules preloaded in the slots. Serious injury and damage could result. Unload any drive modules in enclosure slots to a static-protected area. Do not further lighten the enclosure by removing other components.

Use this checklist, performing each task only in the sequence presented after successful completion of the prior step.

Table 2 Installation checklist tasks

Step	Task	Reference
1	Complete all installation prerequisites	Identified below
2	Unpack the enclosure	"Unpack and prepare the 2U enclosure" on page 21 "Unpack and prepare the 5U enclosure" on page 32
3	Prepare the site for installation of the enclosure into the rack cabinet	"Unpack and prepare the 2U enclosure" on page 21 "Unpack and prepare the 5U enclosure" on page 32
4	For rackmount installation, temporarily move any drive modules not installed in the enclosure to a static-protected area	
5	Install the rackmount kit in the rack cabinet	"Install the 2U rackmount rail kit" on page 22 "Install the 5U rackmount rail kit" on page 33
6	Mount the enclosure into the rack cabinet	"Mount the 2U enclosure into the rack cabinet" on page 25 "Mount the 5U enclosure into the rack cabinet" on page 37
7	Install drive modules in carriers (DDICs) in the enclosure	"Populate the 2U enclosure" on page 27 "Populate the 5U enclosure" on page 41
8	(Optional) Install any additional expansion enclosures	Follow same process for chassis installation up to this step
9	Test for safety electrical earth connection	"Test enclosure electrical earth connection" on page 42
10	Connect all host and any expansion data cables	"Route 2U enclosure data cables and power cords" on page 28
11	Connect all power cords	"Route 5U enclosure data cables and power cords" on page 42

- **Site preparation**
 1. Use the installation checklist.
 2. Clear the site for installation and secure a static-protected area.
- **Before enclosure installation**
 1. Unpack the enclosure in a clear area, using appropriate safety precautions.
 2. Temporarily set aside all drives in carriers (DDICs) into a static-protected area, regardless of how your enclosure or drives ship.
 3. Follow all instructions for installing the provided rackmount rails into the rack cabinet.
 4. Review all related warnings before mounting the enclosure into the rack.
- **Enclosure installation**
 1. Move the enclosure onto a suitable mechanical lift.
 - a. For the 2U enclosures, have two people move the enclosure to a lift.
 - b. For the 5U enclosures, have three people use the provided belt straps to move the enclosure to a lift.
 2. Use a mechanical lift for positioning the enclosure and mounting it into the rack cabinet. Do not use a vacuum lift. To maintain personal and equipment safety, do not use any other method to support the weight of the enclosure during installation or maintenance.
 3. Maintain adequate enclosure clearances, both front and back.
- **Before FRU installation**
 1. Prior to handling the DDICs, make sure you are static-compliant.
 2. Confirm you can easily reach the slots and you can visually inspect the installation of each DDIC in the enclosure, while safely maintaining your balance.
- **DDIC installation**
 1. Only after you securely mount the enclosure in the rack can you retrieve the DDICs from their static-protected area.
 2. Install all DDICs into the proper module slots.
- **Prior to testing the enclosure**
 1. Examine cables and make sure connections are completely secure on both ends.
 2. Adhere to all electrical safety guidelines.

Complete installation prerequisites

The rackmount rails are designed to bear the maximum weight of the expansion enclosure when it is properly mounted in a standard rack cabinet. You can install multiple expansion enclosures in a single rack cabinet.

 **CAUTION** You must use only the supplied rail kit and related mounting hardware.

To complete installation prerequisites:

1. Prepare the host system for the installation by obtaining access to the following items:
 - a. A host computer with the correct firmware, BIOS, and drivers
 - b. A functioning switch connected to a host computer

- c. Tested, good cables for host connection that meet enclosure requirements
 - d. The provided power cords, which meet power specifications
2. Familiarize yourself with system configuration requirements and the enclosure components.
 3. Obtain the following:
 - a. An anti-static wrist or ankle strap for handling static-sensitive components
 - b. A static-protected environment for temporary storage of the enclosure and the FRUs
 - c. A Torx screwdriver, 6-in length, with T10 and T20 bits
 - d. A flat-bladed screwdriver, 6-in length
 - e. A Philips screwdriver, 6-in length
 - f. A mechanical lift with sufficient clearance and capable of safely lifting the enclosure without drive modules
 4. Ensure the rack cabinet is suitable for use with the enclosure.
 - a. A rack cabinet capable of holding 2U or 5U form factors that meets all UL and IEC safety requirements, leveled in all planes with respect to each other
 - b. Adequate clearance in front of the rack cabinet to install the provided rail kit
 - c. A maximum depth of 884mm (34.81 inches) from back of front post to maximum extremity, excluding cabling and door closure considerations
 - d. A rack cabinet that causes a maximum back air pressure of 5 pascals (0.5mm water gauge)
 - e. A rack cabinet constructed to meet the installed weight capacity for the total number of enclosures in the rack cabinet, based on the related maximum weight per enclosure

2U12

A maximum of 32kg (71 lb)

2U24

A maximum of 30kg (60 lb)

5U84

A maximum of 130kg (287 lb)

- f. A maximum operating ambient temperature of 35°C (95°F)
5. Secure sufficient staff to assist with the installation. Minimum staff:
 - a. One qualified service technician for the complete installation procedure
 - b. One spotter to assist with the lift and to assist with the installation from the rear of the rack cabinet
 - c. A total of two people (2U) or three people (5U) to unpack the enclosure and move it onto the mechanical lift

4 Installation of 2U enclosures

Sequentially follow the installation checklist to install the 2U enclosure, which guides you through the related topics.

Unpack and prepare the 2U enclosure

CAUTION Do not operate an expansion enclosure outside the manufacturer's intended use.

- Storage enclosures are suitable for connection to intra-building or non-exposed wiring or cabling only.
- Storage enclosures are suitable for installation in locations where the National Electrical Code (NEC) applies but are not suitable for Outside Plant (OSP) installations.
- Customer facilities must provide for voltages with not more than $\pm 5\%$ fluctuation. Customer facilities must also provide suitable surge protection.

To unpack and prepare the 2U enclosure:

1. Prepare the site for the 2U enclosure installation. This includes meeting all product specifications and providing a clean, clear, static-protected environment prior to unpacking the enclosure.
2. Complete the following actions to complete inspection of the 2U enclosure:
 - a. Examine packaging for damage. This includes cuts, water damage, or shipment mishandling.
 - b. If there is damage, photograph and document it, but do not proceed. Retain original packaging for returns.
 - c. Cut open the package lid to remove all items above the chassis, such as the rails and protective foam, and set aside to gain access the chassis.
3. Locate two people to assist in moving the 2U enclosure chassis in its plastic bag onto the mechanical lift.
 - a. Position a person on each side of the expansion enclosure, grasping the chassis sides, not the front or rear panel.

IMPORTANT Almost all the weight of the expansion enclosure is to the rear, so prepare to lift more from the side of the chassis to the rear than the chassis side to the front.

- b. Simultaneously lift the 2U enclosure, using appropriate safe lifting technique while moving it to the mechanical lift.

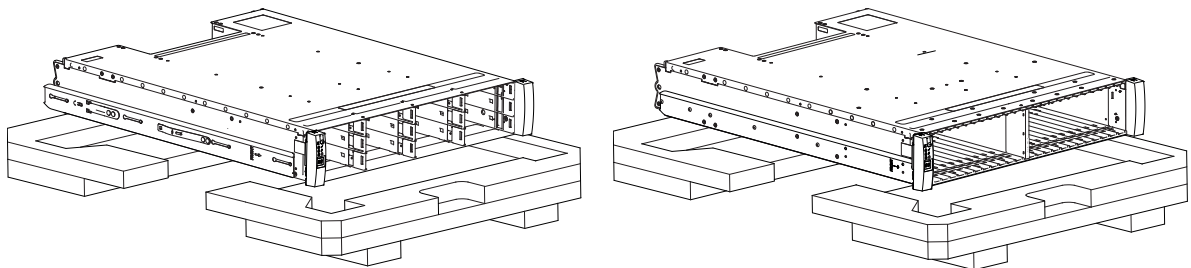

Figure 6 2U12 and 2U24 expansion enclosure packaging, shown without plastic for clarity

4. Slide off the plastic bag to access the chassis while making sure the chassis is centered on the lift.

5. Complete the following actions to prepare the 2U enclosure chassis for installation:
 - a. Facing the chassis front, grasp the right rack flange cover, work the cover free, and set it aside in a safe location.
 - b. Grasp the left rack flange cover, gently work the cover free, and set it aside in a safe location.

Install the 2U rackmount rail kit

The 2U enclosure requires rackmount hardware for installation into a standard 1.2m rack and occupies 2 EIA units of rack space (8.9cm or 3.50 inches) per unit. The rail kit contains a left and right rail designed to handle the 2U enclosure and provide for installation of multiple enclosures without loss of rack space. Product function and user safety hinge on proper installation. This task assumes square mounting holes but pertains to other rack types.

You must take all appropriate rack cabinet safety precautions before mounting a 2U enclosure into a rack.

CAUTION Observe all the following directives:

- Always place the rack cabinet on a flat, leveled surface. Do not install an expansion enclosure into a rack cabinet until you verify the rack cabinet is level.
- Follow prescribed leveling procedures from the rack cabinet manufacturer.
- Never install or remove from the rack cabinet more than one expansion enclosure at a time. This helps prevent the rack cabinet from tipping or falling.
- Verify the rack cabinet meets all safety requirements when configured with expansion enclosures.
- Verify connections comply with all electrical requirements.
- Verify the system complies with all temperature and exhaust requirements.

To adhere to safety precautions when mounting a 2U enclosure into a rack cabinet:

1. Read and observe all warning and caution labels on the 2U enclosure.
2. Verify the rack cabinet is on a flat, leveled surface because any incline or unevenness stresses the rack cabinet and 2U enclosure. A 2U enclosure in an uneven rack cabinet resists smooth rail movement and may distort the chassis.
3. Verify the rack cabinet design supports the total weight of 2U enclosures and has stabilizing features to prevent the rack cabinet from tipping or being pushed over during installation or normal use.
4. Do not lift the 2U enclosure without a mechanical lift. No single person should lift an enclosure without help.
5. Mount 2U enclosures into the rack cabinet from the bottom to the top during installation.
6. Locate lighter 2U enclosures above heavier ones to maximize stability.
7. Remove 2U enclosures from the top of the rack cabinet to the bottom when emptying it.

Required equipment	Qty	Identification
Outer rails, properly oriented	2	N/A
#2 Phillips-head screwdriver, 6-in length	1	N/A
(Optional) 8mm nut driver, 6-in length	1	N/A
Phillips-head screw, M5 x 15, 8mm hex flange	8	

To install the 2U rackmount rail kit:

1. Remove both outer rail assemblies from their packaging.

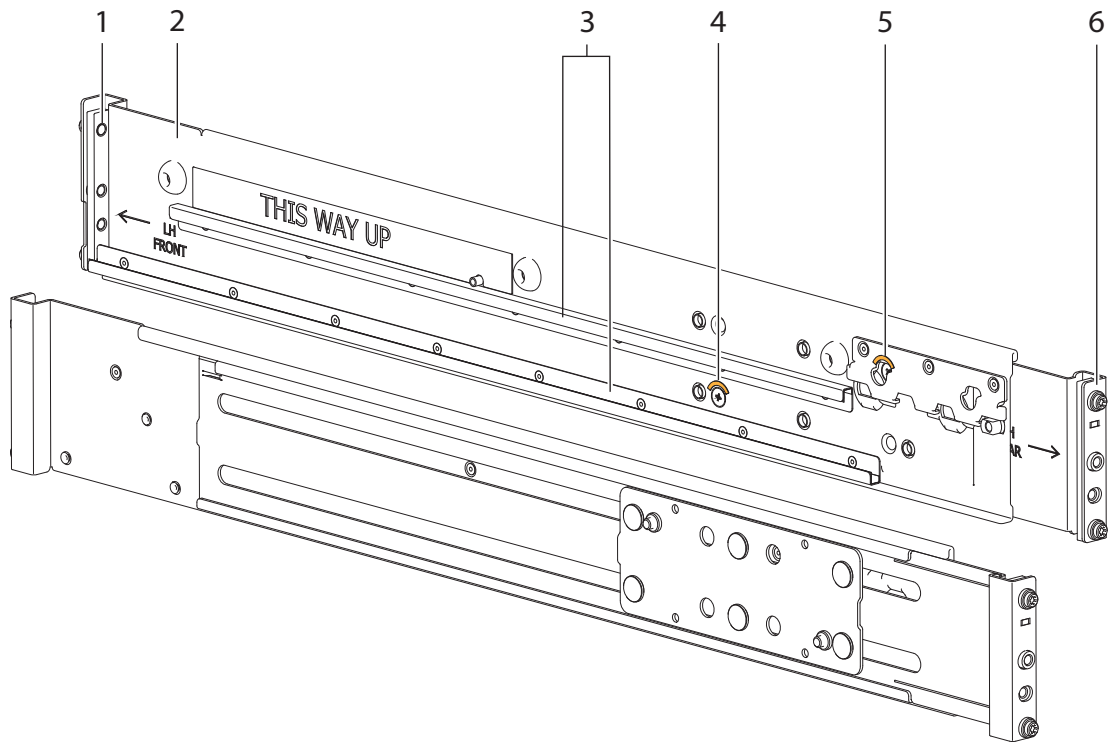

Item	Description	Item	Description
1	Left front mount bracket	4	Set screw, front
2	Left front outer rail	5	Set screw, rear
3	Left rail slides	6	Left rear mount bracket

Figure 7 2U enclosure outer rail components

2. Orient the outer rail with the LH FRONT embossed on it to your left, the other with the RH FRONT embossed on it to your right, and each emboss toward you, facing inward.
3. Loosen, but do not remove, the 2 set screws on each outer rail with a Philips screwdriver.
4. Facing the left side of the rack cabinet, slide the left front mount bracket pins into holes in the front rack post.
5. Bias the left rack mount bracket as far inward as possible, then verify the entirety of the lower rail tab is visible just beyond the inner edge of the front rack mount bracket. This step is crucial to safety and proper 2U enclosure operation.
6. Hold the biased mount bracket in that position.
7. Insert a Phillips-head M5 x 15 screw into the center hole of the front mount bracket and barely tighten against the front rack post using a Philips screwdriver or 8mm nut driver.

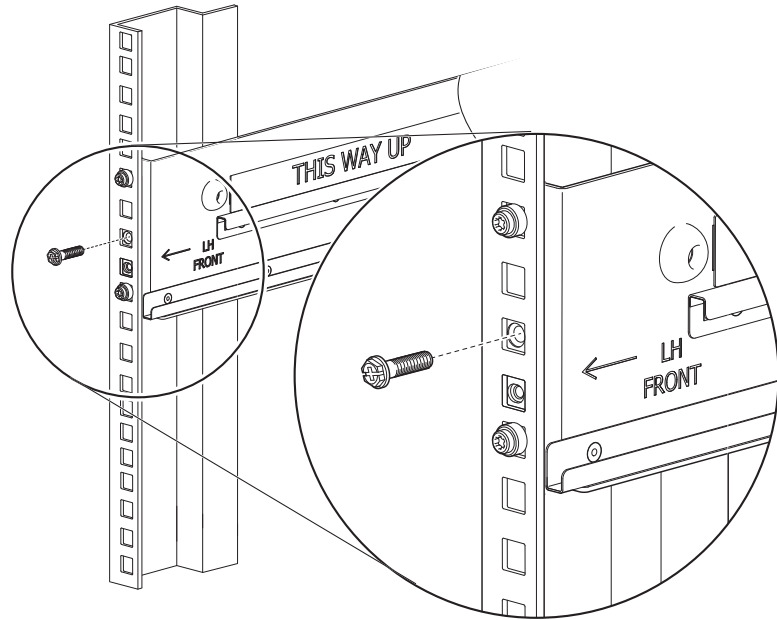

Figure 8 Attachment of front mount bracket to front rack cabinet posts

8. Extend the length of the rail until fully mating the rear mount bracket pins in the mirror location on the rear rack post.

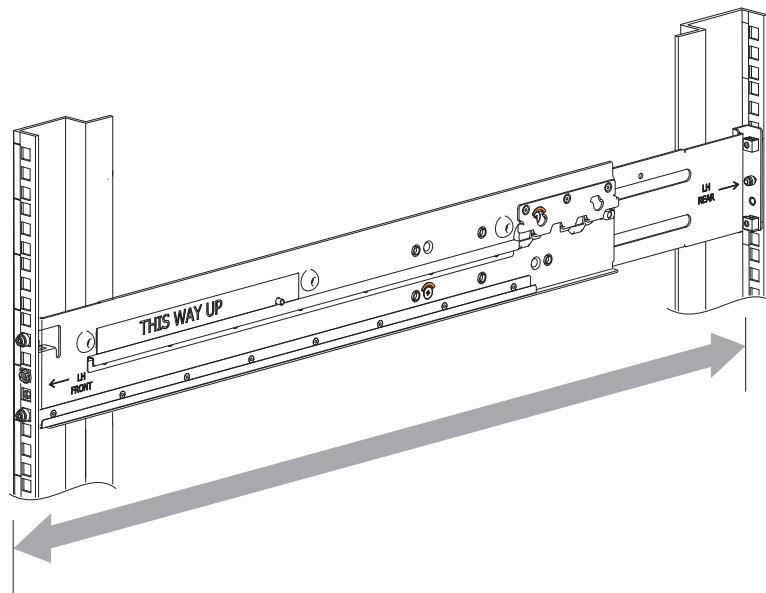

Figure 9 Adjustment of rail length to fit rack cabinet

9. Verify that the rails are level at the same height on both rack posts, and that all mount bracket location pins fully seat in identical locations in the rack posts.
10. Facing the rear of the rack cabinet, insert a Phillips-head M5 x 15 screw into the center hole of the rear mount bracket.

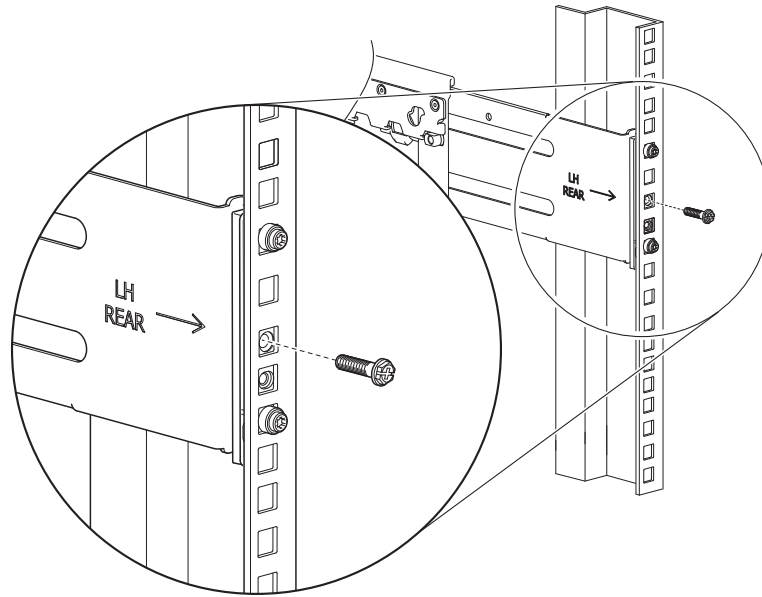

Figure 10 Attachment of rear mount bracket to rear rack cabinet posts

11. Hand tighten firmly against the rack post using an 8mm nut driver or a Phillips screwdriver.
12. Facing the front of the rack cabinet, hand tighten the Phillips-head M5 x 15 screw using an 8mm nut driver or a Phillips screwdriver so that the hex head flange is flush with the front rack post.
13. Fix the adjusted length of the left outer rail by hand tightening both rail slide set screws using a Phillips screwdriver.
14. Repeat the process for the right outer rail.



Mount the 2U enclosure into the rack cabinet

⚠ WARNING! Serious injury and mechanical failure can result if you do not adhere to rack cabinet safety precautions.

- To avoid risk of death or injury from tipping the rack, follow all rack installation guidelines, securing the rack cabinet to the floor with a concrete anchor kit.
- To avoid catastrophic failure of the rack assembly, never exceed rack cabinet weight limits.
- Entirely support the expansion enclosure with the mechanical lift until the enclosure is in the storage position.
- Follow local occupational health and safety guidelines and meet all requirements for manual material handling.

Mounting the 2U enclosure into the rack cabinet is the most critical of installation procedures and requires your full attention. Safety and hardware longevity depend on the rail's smooth function and correct implementation of this task.

- Confirm you comply with all installation requirements for the rack cabinet. See "[Complete installation prerequisites](#)" on [page 19](#).
- Fill the rack cabinet from the bottom to the top, with the heaviest equipment at the bottom.
- Make your approach with the mechanical lift level, straight, and parallel to the rack cabinet. Any skew, warp, or tilt prevents the inner rails attached to the 2U enclosure from properly engaging the outer rails in the rack cabinet.

Required equipment	Qty	Identification
Mechanical lift	1	N/A
Expansion enclosure with attached inner rails	1	N/A
Rack cabinet with installed outer rails	1	N/A
#2 Phillips-head screwdriver, 6-in length	1	N/A
Panhead screw, M5 x 8, #2	2	
Phillips-head screw, M5 x 15, 8mm hex flange	2	

To mount the 2U enclosure into the rack cabinet:

1. Confirm that the outer rails are properly and securely installed in the rack cabinet.
2. Complete the following actions to position the mechanical lift and the 2U chassis:
 - a. Using proper safety precautions, position the 2U chassis on the mechanical lift perpendicular to the lift wheels.
 - b. Move the mechanical lift into position perpendicular to the rack cabinet so that the 2U chassis is parallel to the opening and is a minimum of 12.7cm to 17.8cm (5 to 7 inches) away from the rack cabinet.
 - c. Adjust the mechanical lift height to be as close as possible to the allocated 2U location.
 - d. Moving only the 2U chassis, position it so the attached inner rails align with the outer rails in the rack.

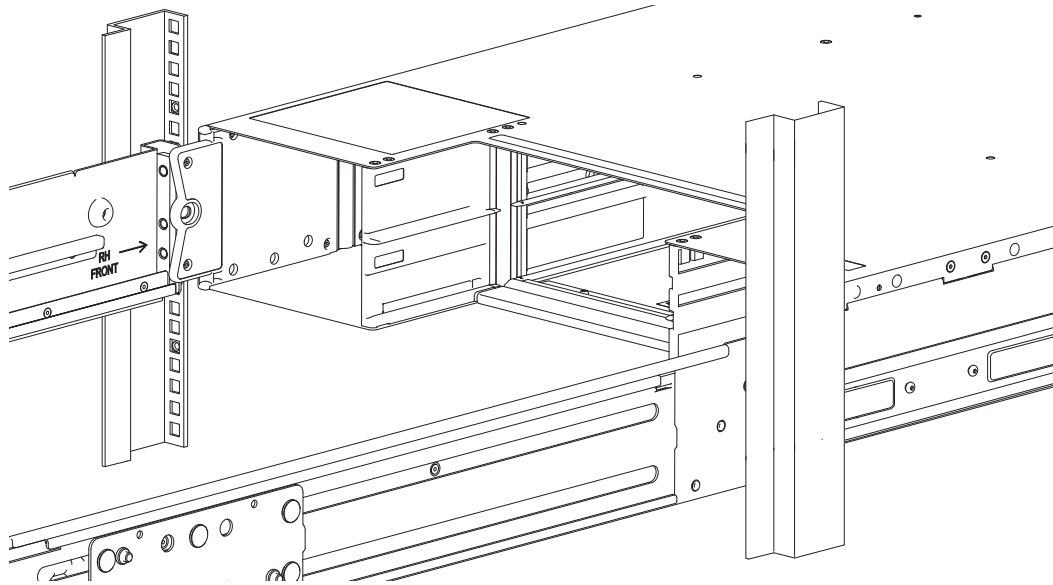

Figure 11 Alignment between 2U chassis and rails (removed rear components for clarity)

3. Complete the following actions to properly secure the 2U chassis on the outer rails:
 - a. Keep the 2U chassis stationary on the lift.
 - b. Verify that both outer rails fully engage the 2U chassis inner rails.
 - c. Guide the chassis inward with the leading edge of each inner rail inside the top and bottom lip of the outer rail.
 - d. Conduct a visual inspection of both sides to verify both inner rails are an equal distance along the outer rail and that the direction is straight in, not at an angle.

4. Complete the following actions to insert the 2U chassis into the rack cabinet:
 - a. Facing the front of the enclosure, carefully exert even pressure on both sides of the 2U enclosure front, inserting the 2U enclosure until the rack ear flanges are flush with the front rack posts.
 - b. Carefully lower the mechanical lift.
 - c. Thoroughly examine the rack rails for issues such as bowing, scraping, resistance, or indicators of misalignment.
5. Complete the following actions to secure the 2U chassis:
 - a. Facing the rear of the enclosure, insert and tighten a Panhead M5 x 8 screw into the tail of each outer rail and through the 2U chassis to secure the rear of the chassis.

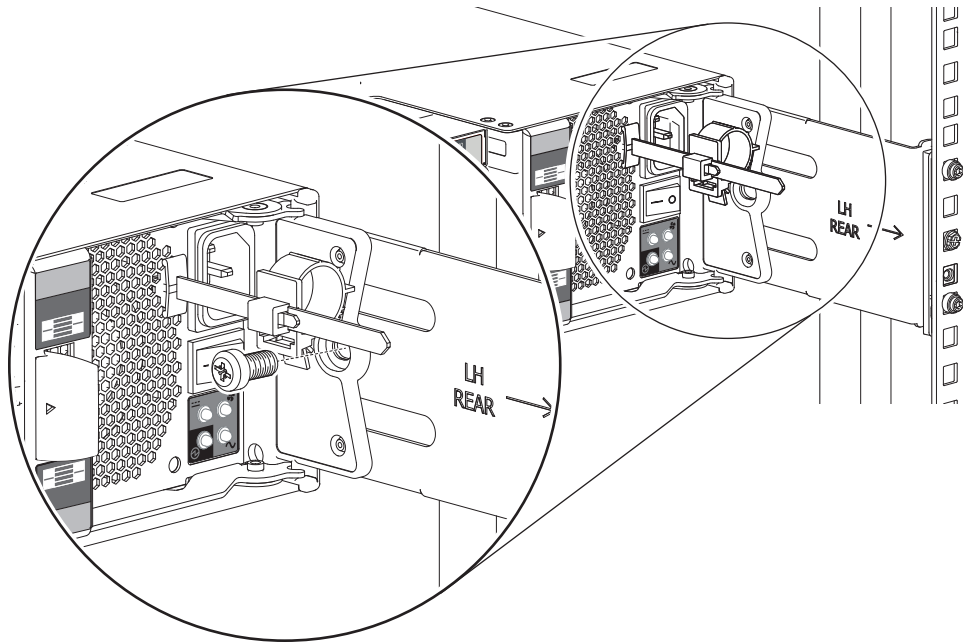

Figure 12 Installation of 2U rear screw to secure chassis to rail

- b. Facing the front of the 2U chassis, insert a Panhead M5 x 8 screw into the operator's (ops) panel with an 8mm nut driver or a Philips screwdriver.
- c. Hand tighten firmly against front rack post at the center of the rack ear flange.
- d. Slide the ops panel cover over the left rack ear flange until flush with the rack post.
- e. Repeat the process for the right rack ear flange and cover.

Populate the 2U enclosure

After successfully mounting the 2U chassis into the rack cabinet, populate the 2U enclosure.

To populate the 2U enclosure:

1. Examine drive carriers for damage.
2. Orient a drive in its carrier (DDIC) so the release latch is to the left for the 2U12 expansion enclosure or to the top for the 2U24 expansion enclosure.
3. Insert it into the first available left-hand slot and press inward until fully seated against the midplane and the latch locks.

4. For the 2U12 expansion enclosure, take the following actions until all slots hold either a DDIC or an optional blank carrier.
 - a. Insert the next DDIC and move across the row to the next slot in the sequence, repeating until the top row is full.
 - b. Repeat until the middle row is full.
 - c. Repeat until the bottom row is full.
5. For the 2U24 expansion enclosure, insert the next DDIC and move across the row to the next slot in the sequence, repeating until all slots hold either a DDIC or an optional blank carrier.

Test enclosure electrical earth connection

After completion of all installation procedures, the enclosure is ready for connection to power. You can only connect the enclosure to a power source that has a safety electrical earth connection. Have a qualified electrical engineer confirm the earth connection meets the product specifications.

 **CAUTION** If you install multiple expansion enclosures in a rack cabinet, the importance of the earth connection increases, since each enclosure increases earth leakage current.

 **IMPORTANT** Only a qualified electrical engineer who meets local and national standards should perform the inspection.

Route 2U enclosure data cables and power cords

Expansion enclosures can be configured as either an EBOD or a JBOD. An EBOD is an expansion enclosure attached to a controller enclosure (RBOD). A JBOD is an expansion enclosure attached directly to a server that is equipped with a SAS HBA or SAS RAID adapter.

Host and data cables provide an efficient highway for data exchanges to and from the 2U enclosure. Cable connections and routing vary, depending on intended use and installation. This section only covers the most common methods.

When properly connected to autonomous power distribution units (PDUs), power cords provide uninterrupted power to the 2U enclosure. You must properly route both cables and power cords while adhering to all grounding requirements and electrical safety precautions.

To adhere to electrical safety precautions:

1. Observe the caution labels affixed to the power cooling modules (PCMs).
2. Confirm PCM input voltage range is 100V to 240V AC at 50Hz to 60Hz, then only operate the 2U enclosure in that range.
3. You must provide a suitable power source with electrical overload protection to meet technical specification requirements.
4. You must use a provided power cord that has a tested, safe electrical earth connection for 2U enclosure power supply.
5. Confirm the 2U enclosure connection to earth before applying power to it.
6. Do not operate a 2U enclosure with less than the provided 2 PCMs, other than to provide in-service maintenance within the required time allotment.

 **IMPORTANT** Use only Cat-6 or above cables with RJ-45 connectors for Base-T connections.

 **IMPORTANT** Use only Seagate approved HD mini-SAS (SFF-8644) x4 data cables that are at least .5m (1.64 feet) in length and do not exceed 3m (9.84 feet) in length to connect to the SAS ports on each input/output module.

Route 2U enclosure host cables and expansion data cables

Each 2U enclosure supports SAS cabling and several methods for connectivity to a switch or the host system. Select data cables that best align with your host environment.

Fault tolerance and performance are key factors in determining how to best optimize your particular system and cabling configuration. This topic assumes a fault-tolerant *reverse* cabling method, since it provides a method of maintaining access to all enclosures in the chain, even if one of the enclosures fails or requires removal. If you use the high-performance *straight-through* cabling method, it is less fault tolerant. When using straight-through cabling, a failed enclosure in the chain prevents access to enclosures further down the chain until you address the fault.

You must comply with all SAS cabling requirements and confirm that they meet all related standards.

⚠ CAUTION Do not create invalid closed loops anywhere along the SAS port cabling configuration. A valid cabling configuration is directional and does not contain any loops between components already in that cabling configuration. An invalid closed loop introduces a circular flow into the cabling configuration that can degrade performance or cause failure.

To route 2U enclosure host and expansion data cables:

1. Take the following actions to connect the host switch or HBA 0A to its related expansion modules. The example below has 3 expansion enclosures directly below the host switch or HBA.

ⓘ IMPORTANT Best practice is to use the expansion Port A for input and Port C for output.

- a. Connect an approved mini-SAS data cables to the host bus adaptor (HBA) or switch, 0A.
 - b. Connect the other end to into SAS port A of the first expansion enclosure, IOM 1A.
 - c. Insert a mini-SAS data cable from SAS port C in the first expansion enclosure, 1A, and connect the other end to SAS port A in the second expansion enclosure, 2A.
 - d. Insert a mini-SAS data cable from SAS port C in the second expansion enclosure, 2A, and connect the other end to SAS port A in the third expansion enclosure, 3A.
2. Take the following actions to connect the host switch or HBA 0B to its related expansion modules. The example below has 3 expansion enclosures directly below the host switch or HBA.

ⓘ IMPORTANT Best practice is to use the expansion Port A for input and Port C for output.

- a. Connect an approved mini-SAS data cables to the host bus adaptor (HBA) or switch, 0B.
- b. Connect the other end to into SAS port A of the last expansion enclosure, IOM 3B.
- c. Insert a mini-SAS data cable from SAS port C in the last expansion enclosure, 3B, and connect the other end to SAS port A in the second expansion enclosure, 2B.
- d. Insert a mini-SAS data cable from SAS port C in the second expansion enclosure, 2B, and connect the other end to SAS port A in the first expansion enclosure, 1B.

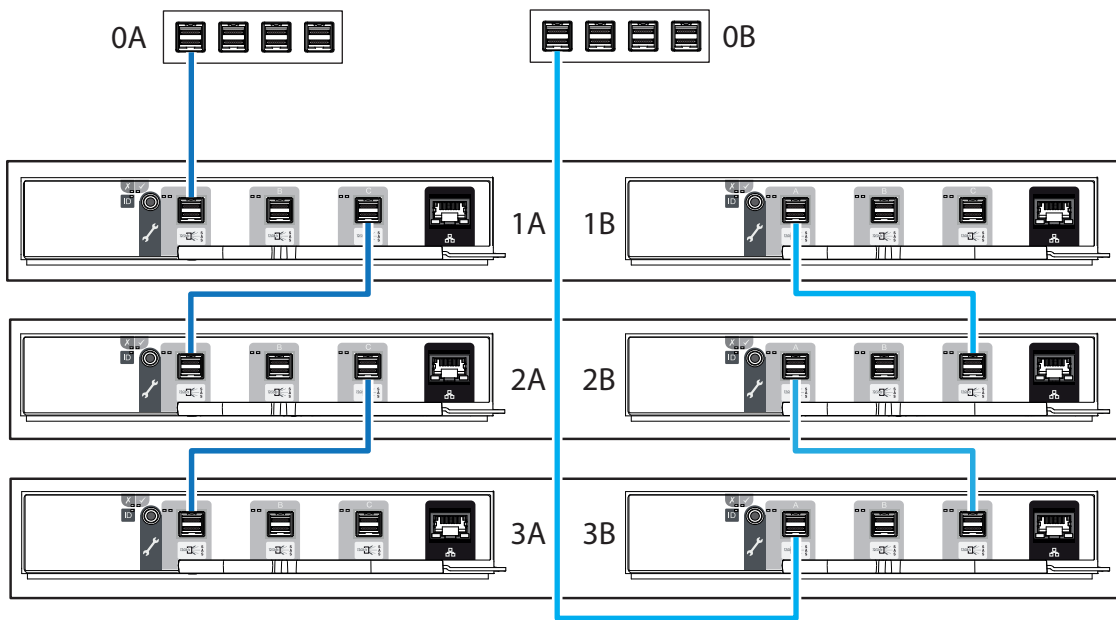

Figure 13 Sample reverse cabling method among the host system and 2U expansion modules

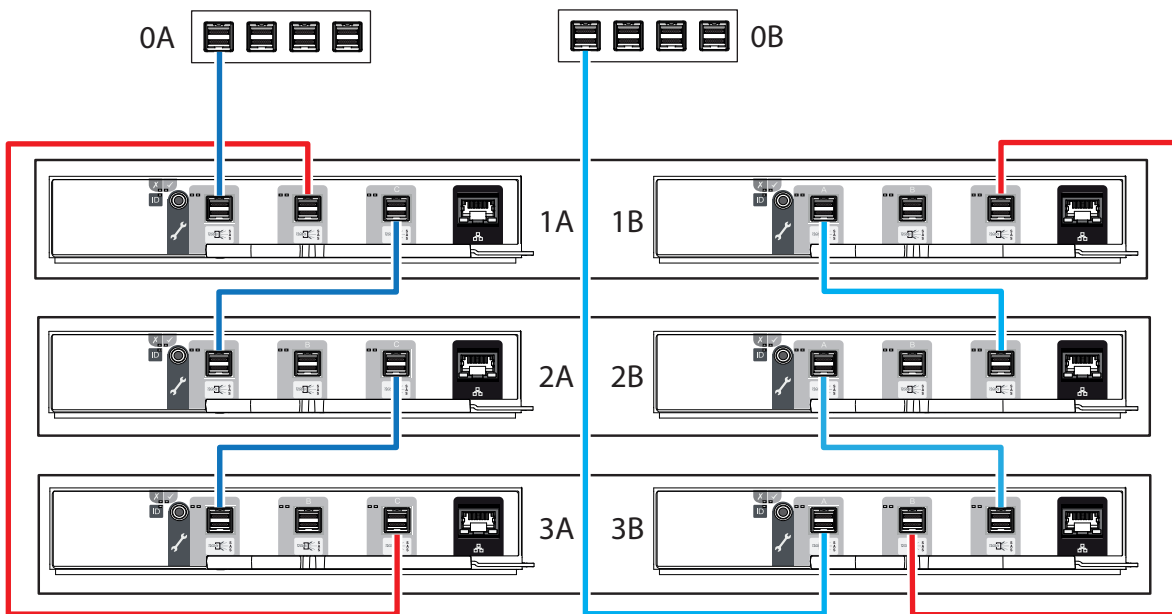

Figure 14 Sample invalid loop (in red) among the host system and 2U expansion modules

Route 2U enclosure power cords

This basic task connects the supplied power cords to the redundant power cooling modules (PCMs) and then to independent power distribution units (PDUs) that are connected to an uninterruptible power system. You must only connect PDUs to a

power source that has a safety electrical earth connection.

CAUTION Use only power cords supplied in the installation kit or those that meet product specifications.

CAUTION Adhere to power source and power connection requirements to avoid harm to equipment.

- Only connect the power cooling module (PCM) to power sources that comply with product specifications and labels.
 - Always remove all power connections before you remove a PCM from the storage or expansion enclosure.
-

To route 2U enclosure power cords:

1. Select both power cords from the packaging and remove the cable ties.
2. Facing the rear of the rack cabinet, connect a power cord connector to each PCM.
3. Route the left power cord below the left fan and connect the plug to an outlet on an independent PDU, allowing a minimum of slack.
4. Route the right power cord below the right fan and connect the plug to an outlet on an independent PDU, allowing a minimum of slack.

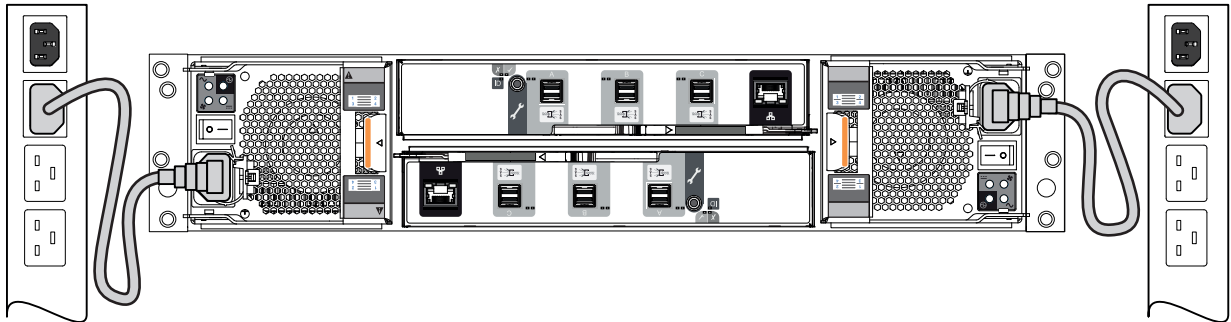

Figure 15 2U power cord routing to independent power distribution units

5. Secure each power cord, using the built-in secure ties on the PCM.
6. Proceed with routing data cables in the next tasks, leaving the power on sequence until after you complete all other cabling tasks and are fully ready to test your connections.

5 Installation of 5U enclosures

Sequentially follow the installation checklist to install the 5U enclosure.

Unpack and prepare the 5U enclosure

CAUTION Do not operate an expansion enclosure outside the manufacturer's intended use.

- Storage enclosures are suitable for connection to intra-building or non-exposed wiring or cabling only.
- Storage enclosures are suitable for installation in locations where the National Electrical Code (NEC) applies but are not suitable for Outside Plant (OSP) installations.
- Customer facilities must provide for voltages with not more than $\pm 5\%$ fluctuation. Customer facilities must also provide suitable surge protection.

To unpack and prepare the 5U enclosure:

1. Prepare the site for the 5U enclosure installation. This includes meeting all product specifications and providing a clean, clear, static-protected environment prior to unpacking the 5U enclosure.
2. Complete the following actions to complete inspection of the 5U enclosure:
 - a. Examine packaging for damage. This includes cuts, water damage, or evidence of mishandling during shipment.
 - b. If there is damage, photograph and document it, but do not proceed. Retain all original packaging for returns.
 - c. Remove pallet strapping and all protective foam above the 5U enclosure to access it.
3. Slide the plastic bag aside to allow access to the chassis.

WARNING! The box is deep, and the chassis is very heavy. Do not attempt to lift by yourself.

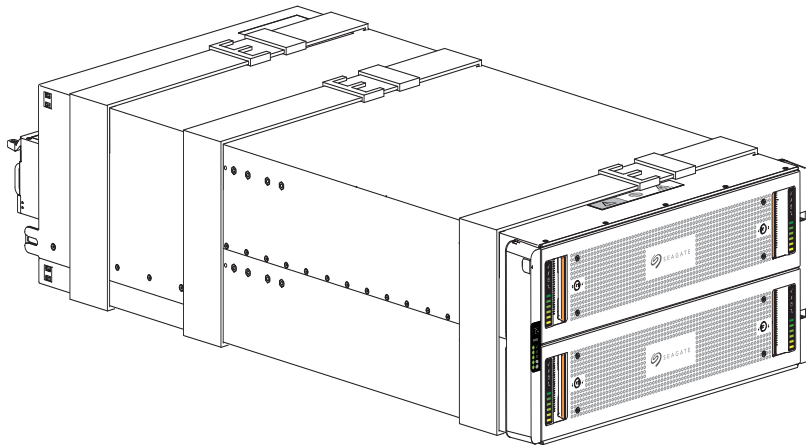



Figure 16 Default belt straps already around the 5U expansion enclosure

4. Locate three people to assist in moving the 5U enclosure in its plastic bag onto the mechanical lift, using an appropriate safe lifting technique to perform the following actions:
 - a. Position one person at the front to grip the front belt strap securely by both loops, not by any portion of the front or rear panel areas.
 - b. Position one person at each rear corner to grip both rear belt straps by the loops on that side.
 - c. Simultaneously lift the 5U enclosure, using appropriate safe lifting technique while moving it to a static-protected location, and then to the mechanical lift for mounting to the rack cabinet.
5. Slide off the plastic bag to access the chassis while making sure the chassis is centered on the lift.
6. Complete the following actions to prepare the 5U enclosure chassis for installation:
 - a. Facing the front of the chassis, grasp the right rack flange cover, gently work the cover free, and set it aside in a safe location.
 - b. Grasp the left rack flange cover, gently work the cover free, and set it aside in a safe location.

Install the 5U rackmount rail kit

The 5U enclosure requires rackmount hardware for installation into a standard 1.0m or 1.2m rack and occupies 5 EIA units of rack space (22.22cm or 8.75 inches) per unit. The rail kit contains a left and right rail designed and tested to handle the 5U enclosure and provide for installation of multiple enclosures without loss of rack space. Product function and user safety hinge on their proper installation. The following task assumes your rack posts have square mounting holes.

You must take all appropriate rack cabinet safety precautions before mounting the 5U enclosure into a rack.

 **CAUTION** Observe all the following directives:

- Always place the rack cabinet on a flat, leveled surface. Do not install an expansion enclosure into a rack cabinet until you verify the rack cabinet is level.
- Follow prescribed leveling procedures from the rack cabinet manufacturer.
- Never install or remove from the rack cabinet more than one expansion enclosure at a time. This helps prevent the rack cabinet from tipping or falling.
- Verify the rack cabinet meets all safety requirements when configured with expansion enclosures.
- Verify connections comply with all electrical requirements.
- Verify the system complies with all temperature and exhaust requirements.

To adhere to safety precautions when mounting the 5U enclosure into a rack cabinet:

1. Read and observe all warning and caution labels on the 5U enclosure.
2. Verify the rack cabinet is on a flat, leveled surface because any incline or unevenness stresses the rack cabinet and the 5U enclosure. A 5U enclosure in an uneven rack cabinet resists smooth movement on the rails and possibly distorts the 5U enclosure.
3. Verify the rack cabinet design supports the total weight of 5U enclosures and has stabilizing features to prevent the rack cabinet from tipping or being pushed over during installation or normal use.
4. Do not lift the 5U enclosure without a mechanical lift. No single person should ever lift a 5U enclosure without assistance.
5. Mount 5U enclosures into the rack cabinet from the bottom to the top during installation.

6. Locate lighter 5U enclosures above heavier ones to maximize stability.
7. Remove 5U enclosures from the top of the rack cabinet to the bottom when emptying it.

Required equipment	Qty	Identification
Outer rails, properly oriented	2	N/A
#2 Phillips-head screwdriver, 6-in length	1	N/A
(Optional) 8mm nut driver, 6-in length	1	N/A
Phillips-head screw, M5 x 15, 8mm hex flange	8	

To install the 5U rackmount rail kit:

1. Remove both rail assemblies from their packaging.
2. Orient the rail with the LH FRONT embossed on it to your left, the other with the RH FRONT embossed on it to your right, and each emboss toward you, facing inward.

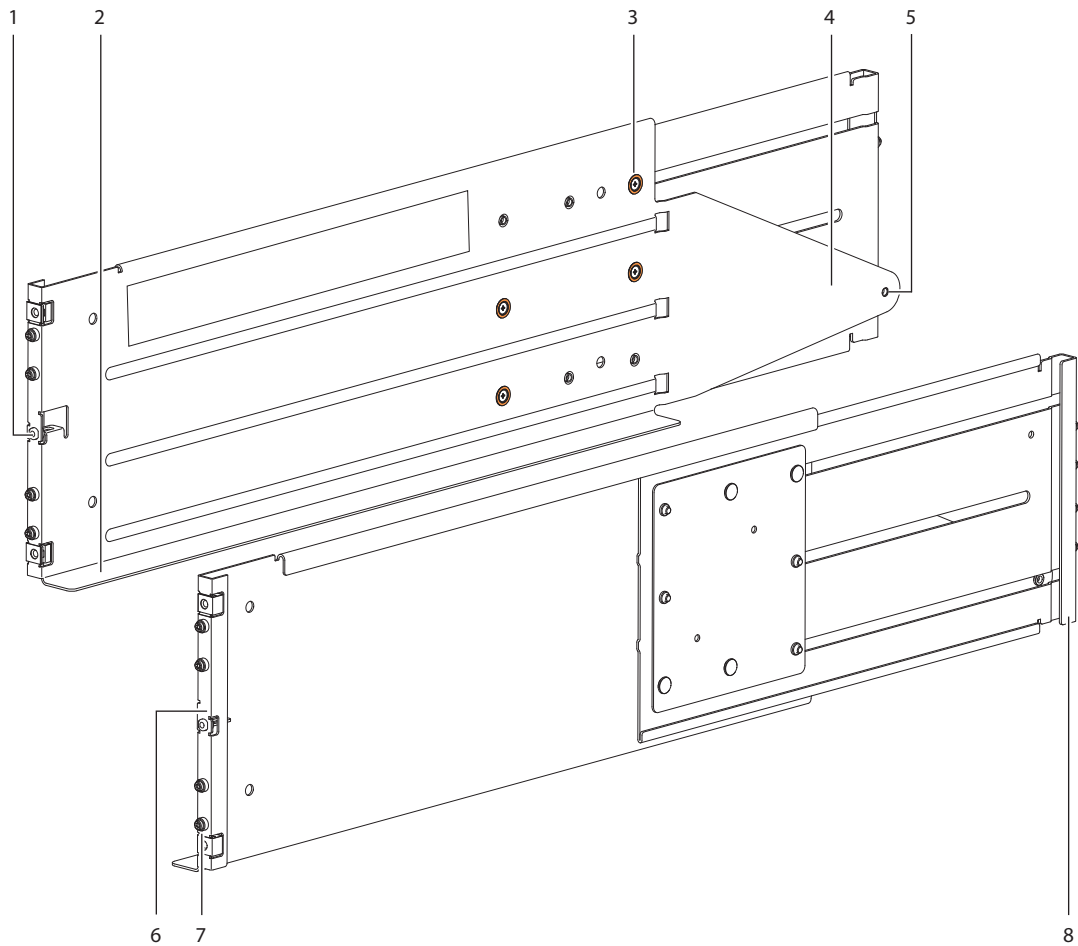

Item	Description	Item	Description	Item	Description	Item	Description
1	Left front mount bracket	3	Rail slide set screw	5	Rear mount	7	Rack pin
2	Left rail shelf	4	Left rear tail	6	Right front mount bracket	8	Right rear mount bracket

Figure 17 5U left and right rail components

3. Loosen, but do not remove, all 4 rail slide set screws on each rail with a Philips screwdriver.
4. Select the left rail, then face the left side of the rack cabinet and slide the front mount bracket pins into the desired slots in the front rack post.
5. Insert a Phillips-head M5 x 15 screw through the rack post into the center of the front rack mount bracket and barely tighten against the front rack post, using an 8mm nut driver or a Philips screwdriver.

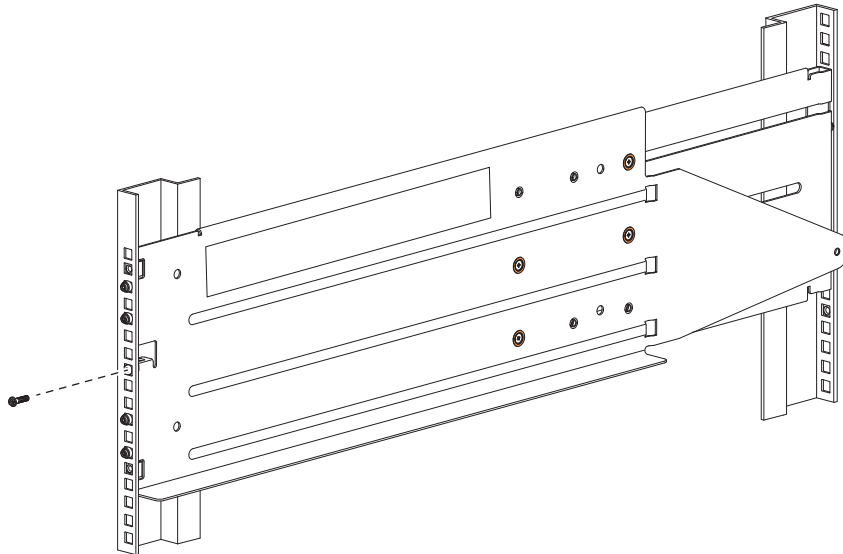

Figure 18 Insertion of 5U front mount bracket screw

6. Extend the length of the rail until the rear mount bracket pins in the mirror location on the rear rack post.
7. Verify that the rails are level at the same height on both rack posts, and that all location pins fully seat in the rack posts.
8. Facing the rear of the rack cabinet, insert 2 Phillips-head M5 x 15 screws into the top and bottom holes of the rear mount bracket.

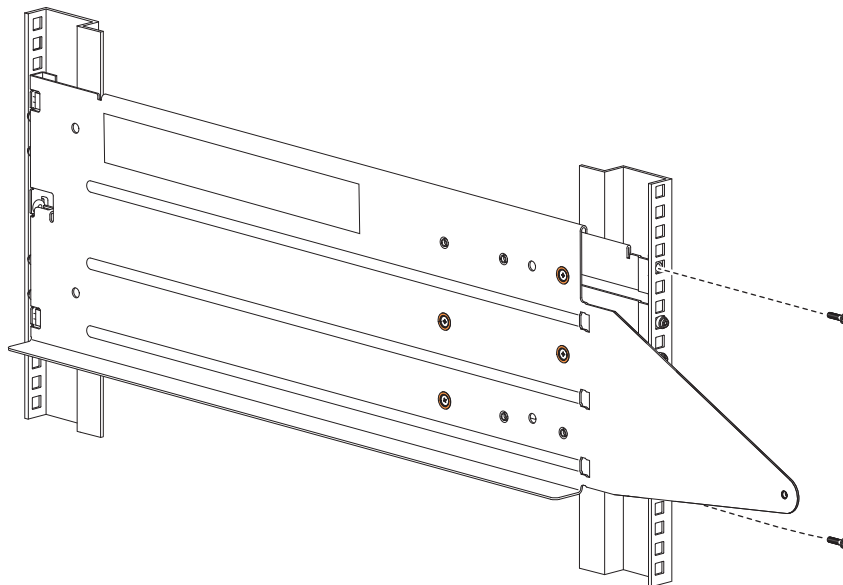

Figure 19 Insertion of 5U rear mount bracket screws

9. Hand tighten firmly against the rack post using an 8mm nut driver or a Phillips screwdriver.
10. Facing the front of the rack cabinet, hand tighten both of the Phillips-head M5 x 15 screws using an 8mm nut driver or a Phillips screwdriver so that the hex head flanges are flush with the front rack post.
11. Fix the adjusted length of the left rail by hand tightening all 4 rail slide set screws using a Phillips screwdriver.
12. Repeat the process for the right rail.



Mount the 5U enclosure into the rack cabinet

⚠ WARNING! Serious injury and mechanical failure can result if you do not adhere to rack cabinet safety precautions.

- To avoid risk of death or injury from tipping the rack, follow all rack installation guidelines, securing the rack cabinet to the floor with a concrete anchor kit.
- To avoid catastrophic failure of the rack assembly, never exceed rack cabinet weight limits.
- Entirely support the expansion enclosure with the mechanical lift until the enclosure is in the storage position.
- Follow local occupational health and safety guidelines and meet all requirements for manual material handling.

Mounting the 5U enclosure into the rack cabinet is the most critical of the installation procedures and requires your full attention. Safety and hardware longevity depend on rails' smooth function and correct implementation of this task.

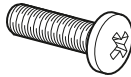
- Make sure there is sufficient clearance for a technician and the 5U enclosure when a drawer is fully extended.
- Observe rack cabinet weight limits.
- Fill the rack cabinet from the bottom to the top, with the heaviest equipment at the bottom.
- Make your approach with the mechanical lift level, straight, and parallel to the rack cabinet. Any skew, warp, or tilt prevents the 5U enclosure from properly resting on the rackmount shelf in the rack cabinet.

Required equipment	Qty	Identification
Mechanical lift	1	N/A
5U enclosure with attached inner rails	1	N/A
Rack cabinet with installed outer rails	1	N/A
#2 Phillips-head screwdriver, 6-in length	1	N/A
(Optional) 8mm nut driver, 6-in length	1	N/A
Panhead screw, M5 x 8, #2	4	
Panhead screw, 10-32 X 3/4-in	6	
Lock washer, M5, T type B	6	
Washer, M5, 10 x 1.6mm	6	

To mount the 5U enclosure into the rack cabinet:

1. Confirm that the outer rails are properly and securely installed in the rack cabinet.
2. Confirm that the expansion enclosure does not contain any drives, so the chassis has empty drawers.
3. Complete the following actions to position the mechanical lift and the 5U chassis:
 - a. Using proper safety precautions, position the 5U chassis on the mechanical lift perpendicular to the lift wheels.
 - b. Move the mechanical lift into position perpendicular to the rack cabinet so that the expansion enclosure is parallel to the opening and is a minimum of 12.7cm to 17.8cm (5 to 7 inches) away from the rack cabinet.
 - c. Adjust the mechanical lift height to be as close as possible to the allocated 5U location.
 - d. Moving only the 5U chassis, position it so the chassis aligns with the outer rails in the rack.

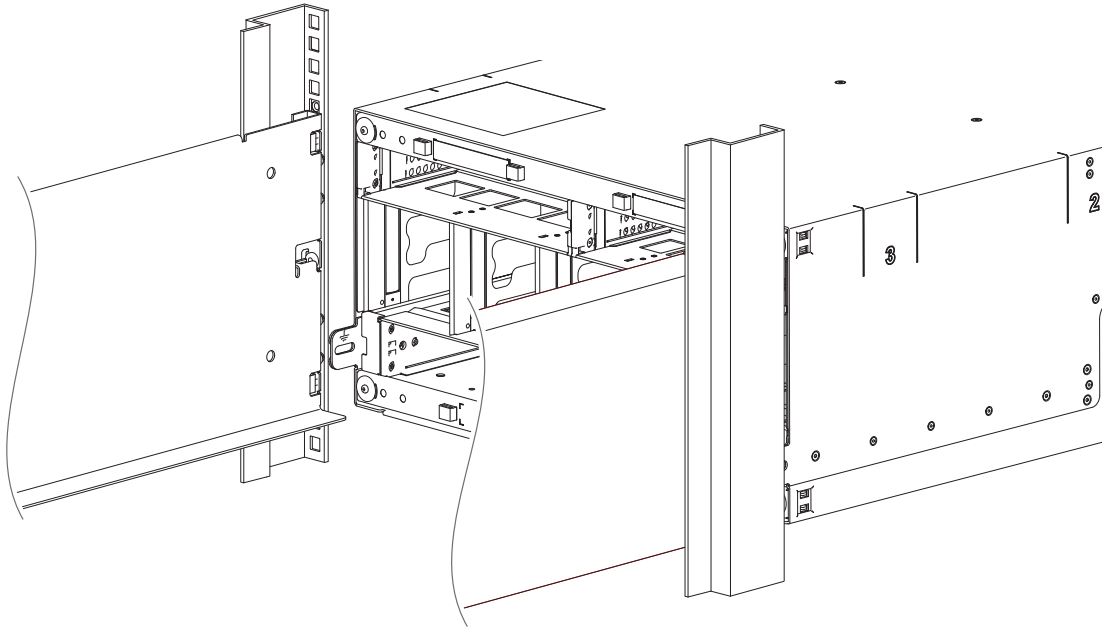

Figure 20 Alignment between 5U chassis and rails, minus rear components for clarity

4. Complete the following actions to properly secure the 5U chassis on its rails:
 - a. Keep the 5U chassis stationary on the mechanical lift.
 - b. Conduct a visual inspection of both sides to verify the bottom of the 5U enclosure chassis rests squarely on the front of the bottom shelf of the outer rail and that the direction is straight in, not at an angle.
5. Complete the following actions to insert the 5U chassis into the rack cabinet:
 - a. Facing the front of the enclosure, carefully exert even pressure on both sides of the 5U enclosure front, inserting the 5U enclosure until the rack ear flanges are flush with the front rack posts.
 - b. Carefully lower the mechanical lift.
 - c. Thoroughly examine the rack rails for issues such as bowing, scraping, resistance, or indicators of misalignment.
6. Complete the following actions to secure the 5U chassis:
 - a. Remove and set aside the operator's (ops) panel.
 - b. Thread a lock washer and then a washer onto each of 2 Panhead 10-32 screws.
 - c. Facing the front of the enclosure, insert a Panhead 10-32 screw with washers into the top and bottom holes in the ops panel, then hand tighten firmly against front rack post with a Phillips screwdriver.

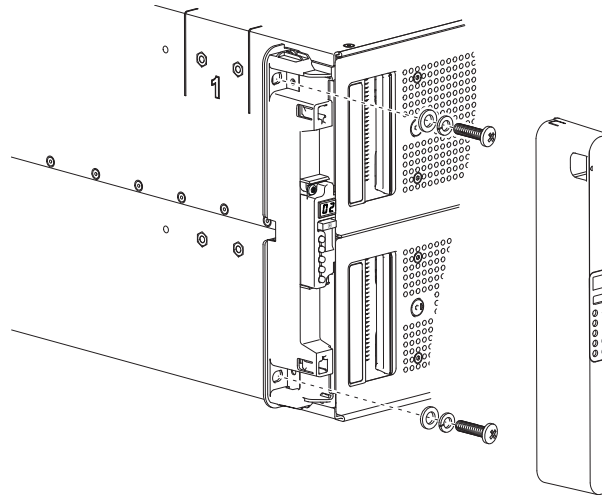

Figure 21 Secure chassis operator's panel to rack posts

- d. Slide the ops panel cover over the left rack ear flange until flush with the rack post.
- e. Repeat the process for securing the right rack ear flange and replacing the right rack ear cover.
- f. Facing the rear of the enclosure, insert and tighten an Panhead M5 x 8 screw through the chassis and into the tail of each outer rail with a Phillips screwdriver to secure the rear of the chassis.

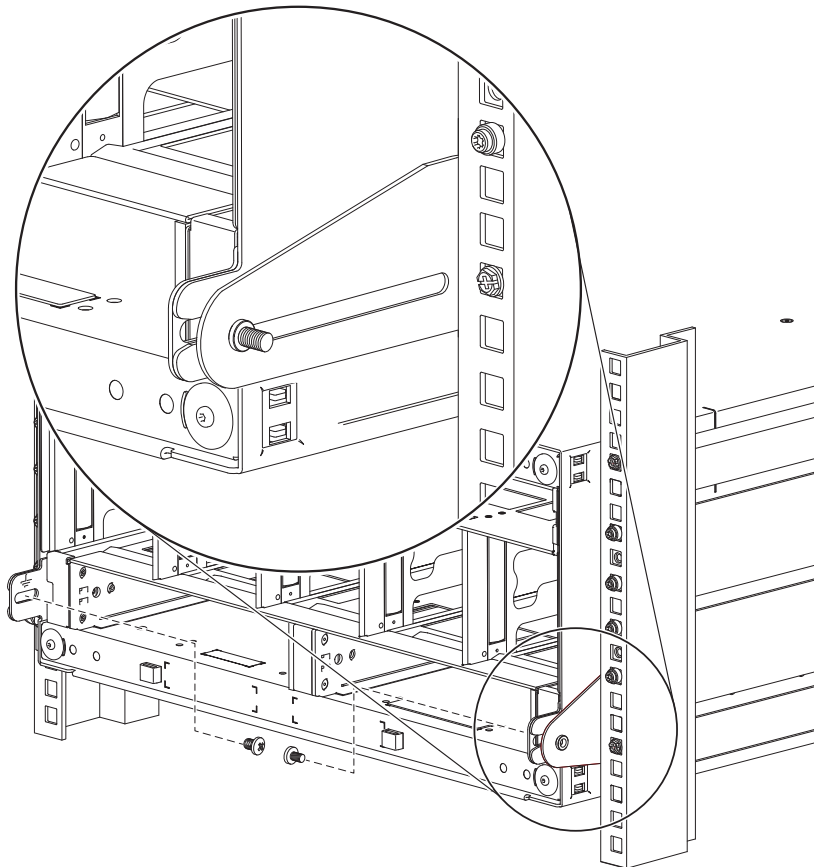

Figure 22 5U rear chassis connection to outer rails, detail, minus rear components for clarity

Access a drawer

Each tamper-resistant drawer contains 42 slots for drives in carriers (DDICs). The drawer supports its DDIC contents and own weight when partially or fully open. A safety latching mechanism prevents access to more than one drawer at a time.

CAUTION Only open a drawer for no more than 10 minutes, or you will compromise airflow and cooling. DDICs are hot-swappable.

To access a drawer:

1. Confirm the drawer is in the unlocked position. If it is locked, use a T20 Torx driver to unlock each drawer pull handle by turning both locks counterclockwise on each drawer.
2. Complete the following actions to open the upper drawer:
 - a. Facing the front of the 5U enclosure, press and hold both drawer pull handles while pulling outward.
 - b. Stop as the drawer rails engage the safety lock latches, and then access three rows of slots for drive modules in their carriers (DDICs).
3. Complete the following actions to close the upper drawer:
 - a. Press and hold the safety lock latches with the blue touchpoint at the front of both extended drawer slide rails.

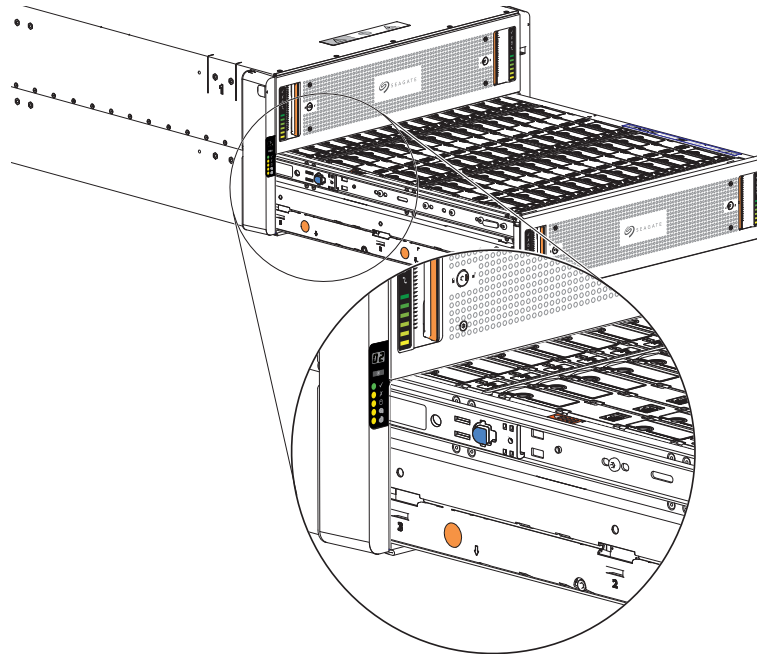

Figure 23 Safety lock to release left drawer slide rail (lower drawer used for relational clarity)

- b. Pressing simultaneously inward, begin sliding the upper drawer back into place until the safety lock clears the opening.
 - c. Placing the heels of both palms against the face of the drawer near the anti-tamper locks, exert even inward pressure until the drawer is almost flush with the rack ear flanges.
 - d. Simultaneously press inward and hold both drawer pull handles as you push the drawer closed until it fully latches.
4. (Optional) Use a T20 Torx driver to lock each drawer pull handle by fully turning both locks clockwise on each drawer, and then confirm the locks properly latched by attempting to open the drawer.

Populate the 5U enclosure

After successfully mounting the 5U chassis into the rack cabinet, populate the 5U enclosure.

CAUTION If you partially populate the expansion enclosure with drives in their carriers (DDICs), you must comply with several additional requirements.

- You must install a minimum of DDICs. Populate in rows, DDICs at a time, from front to back of the drawer, and alternate between drawers.
 - a. Fill the front row in Drawer 1, then front row in Drawer 2.
 - b. the middle row in Drawer 1, then the middle row in Drawer 2.
 - c. the back row in Drawer 1, then the back row in Drawer 2.

The total number of populated drawer rows cannot differ by more than 1 row.

- Populate rows with DDICs that have the same form factor and same rotational speed.
- Do not mix drive types within the same drawer.

To populate the 5U enclosure:

1. Complete all actions to open the upper drawer. See "[Access a drawer](#)" on the previous page.
2. Complete the following actions to fully populate the upper drawer:
 - a. Select a DDIC and orient it, so the LED is towards the drawer front and the release latch arrow towards the rear.

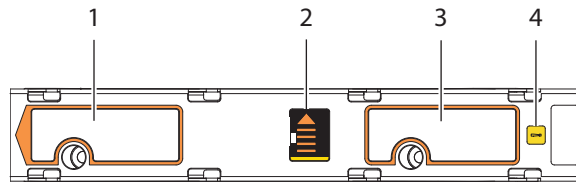

Item	Description	Item	Description
1	Upper portion of carrier latch	3	Lower portion of carrier latch
2	Release latch, release latch arrow, open state	4	Fault condition LED

Figure 24 Carrier latch features

- b. Align the carrier with the first empty drawer slot to the front far left, then lower it fully into the slot.
- c. Push the DDIC down until the top is flush with the top of the slot.
- d. While holding it against the bottom of the slot, slide the top latch toward the rear of the drawer until it locks into place and the DDIC release latch locks.



Figure 25 Release latch open and unlocked



Figure 26 Release latch properly locked

- e. Select the next DDIC, orient it so the LED is towards the drawer front, and insert into the next slot in the same manner.
- f. Repeat, moving to the next slot in the sequence, until you complete the row.

- g. Populate the next two rows in sequence.
- h. Verify that all drives are at the same level and all DDIC release latches are properly locked.

 **CAUTION** Do not proceed to close the drawer unless all DDICs are in a fully locked position or DDIC height can inhibit or completely prevent drawer access once you close it.

3. Complete all actions to close the upper drawer. See "Access a drawer" on page 40.
4. Open the lower drawer and repeat the DDIC installation
5. Following the same drawer closure process, completely close the drawer until it fully latches.

Test enclosure electrical earth connection

After completion of all installation procedures, the enclosure is ready for connection to power. You can only connect the enclosure to a power source that has a safety electrical earth connection. Have a qualified electrical engineer confirm the earth connection meets the product specifications.

 **CAUTION** If you install multiple expansion enclosures in a rack cabinet, the importance of the earth connection increases, since each enclosure increases earth leakage current.

 **IMPORTANT** Only a qualified electrical engineer who meets local and national standards should perform the inspection.

Route 5U enclosure data cables and power cords

Expansion enclosures can be configured as either an EBOD or a JBOD. An EBOD is an expansion enclosure attached to a controller enclosure (RBOD). A JBOD is an expansion enclosure attached directly to a server that is equipped with a SAS HBA or SAS RAID adapter.

When properly connected to autonomous power distribution units (PDUs), power cords provide uninterrupted power to the 5U enclosure. Host and data cables provide an efficient highway for data exchanges to and from the 5U enclosure. This section only covers the most common methods.

When properly connected to autonomous power distribution units (PDUs), power cords provide uninterrupted power to the 5U enclosure. You must properly route both while adhering to all grounding requirements and electrical safety precautions.

To adhere to electrical safety precautions:

1. Observe the caution labels affixed to the power supply units (PSUs).
2. Confirm PCM input voltage range is 100V to 240V AC at 50Hz to 60Hz, then only operate the 5U enclosure in that range.
3. You must provide a suitable power source with electrical overload protection to meet technical specification requirements.
4. You must use a provided power cord that has a tested, safe electrical earth connection for the 5U enclosure power supply.
5. Confirm the 5U enclosure connection to earth before applying power to it.
6. Do not operate the 5U enclosure with less than the provided 2 PSUs and 5 fan control modules (FCMs, other than to provide in-service maintenance within the required time allotment.

 **IMPORTANT** Use only Seagate approved HD mini-SAS (SFF-8644) x4 data cables that are at least .5m (1.64 feet) in length and do not exceed 3m (9.84 feet) in length to connect to the SAS ports on each input/output module.

Route 5U enclosure host cables and expansion data cables

Fault tolerance and performance are key factors in determining how to best optimize your system and cabling configuration. This topic assumes a fault-tolerant *reverse* cabling method, since it provides a method of maintaining access to all enclosures in the chain, even if one of the enclosures fails or requires removal. If you use a *straight-through* cabling method, optimized for high performance, it is less fault tolerant. When using straight-through cabling, a failed enclosure in the chain prevents access to enclosures further down the chain until you address the fault.

You must comply with all SAS cabling requirements and confirm that they meet all related standards.

⚠ CAUTION Do not create invalid closed loops anywhere along the SAS port cabling configuration. A valid cabling configuration is directional and does not contain any loops between components already in that cabling configuration. An invalid closed loop introduces a circular flow into the cabling configuration that can degrade performance or cause failure.

To route 5U enclosure and expansion data cables:

1. Take the following actions to connect the host switch or HBA 0A to its related expansion modules. The example below has 3 expansion enclosures directly below the host switch or HBA.

ⓘ IMPORTANT Best practice is to use the expansion Port A for input and Port C for output.

- a. Connect an approved mini-SAS data cables to the host bus adaptor (HBA) or switch, 0A.
 - b. Connect the other end to into SAS port A of the first expansion enclosure, IOM 1A.
 - c. Insert a mini-SAS data cable from SAS port C in the first expansion enclosure, 1A, and connect the other end to SAS port A in the second expansion enclosure, 2A.
 - d. Insert a mini-SAS data cable from SAS port C in the second expansion enclosure, 2A, and connect the other end to SAS port A in the third expansion enclosure, 3A.
2. Take the following actions to connect the host switch or HBA 0B to its related expansion modules. The example below has 3 expansion enclosures directly below the host switch or HBA.

ⓘ IMPORTANT Best practice is to use the expansion Port A for input and Port C for output.

- a. Connect an approved mini-SAS data cables to the host bus adaptor (HBA) or switch, 0B.
- b. Connect the other end to into SAS port A of the last expansion enclosure, IOM 3B.
- c. Insert a mini-SAS data cable from SAS port C in the last expansion enclosure, 3B, and connect the other end to SAS port A in the second expansion enclosure, 2B.
- d. Insert a mini-SAS data cable from SAS port C in the second expansion enclosure, 2B, and connect the other end to SAS port A in the third expansion enclosure, 1B.

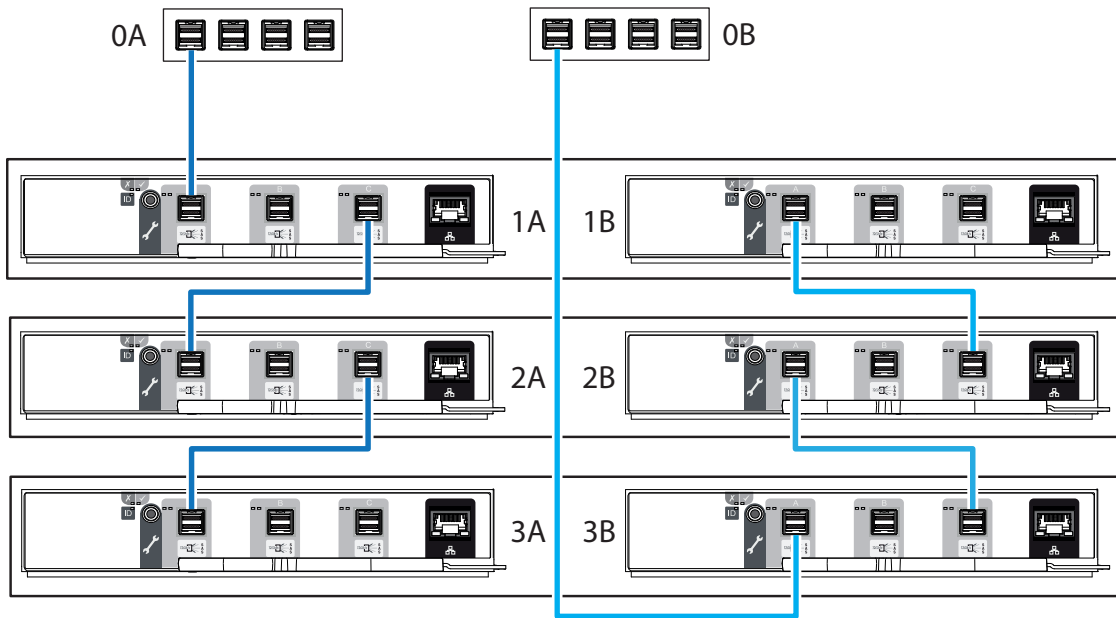

Figure 27 Sample reverse cabling method among the 5U host system and expansion modules

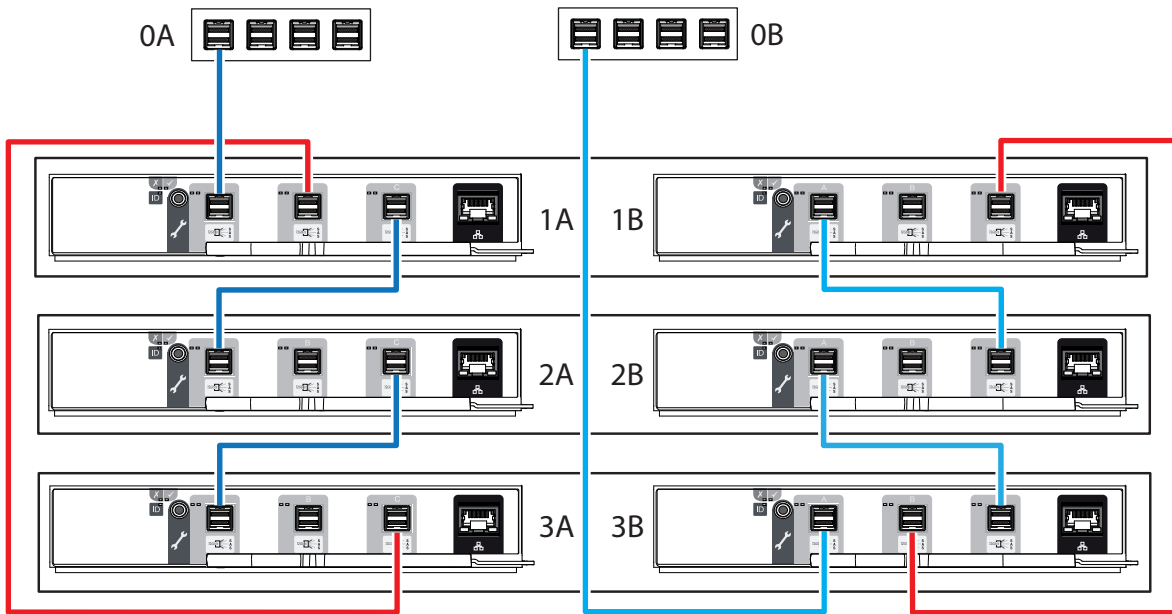

Figure 28 Sample invalid loop (in red) among the 5U host system and expansion modules

Route 5U enclosure power cords

This task provides direction to connect supplied power cords to the redundant power supply units (PSUs) connected to an uninterruptible power system. Only connect PDUs to a power source with a safety electrical earth connection.

CAUTION Use only power cords supplied in the installation kit or those that meet product specifications.

CAUTION Adhere to power source and power connection requirements to avoid harm to equipment.

- Only connect the power supply unit (PSU) to power sources that comply with product specifications and labels.
 - Always remove all power connections before you remove a PSU from the storage or expansion enclosure.
-

To route 5U enclosure power cords :

1. Select both power cords from the packaging and remove the cable ties.
2. Facing the rear of the rack cabinet, connect a power cord connector to each PSU.
3. Route the left power cord below the left outermost fan and connect the plug to an outlet on an independent power distribution unit (PDU), allowing a minimum of slack.
4. Route the right power cord below the right outermost fan and connect the plug to an outlet on an independent PDU, allowing a minimum of slack.

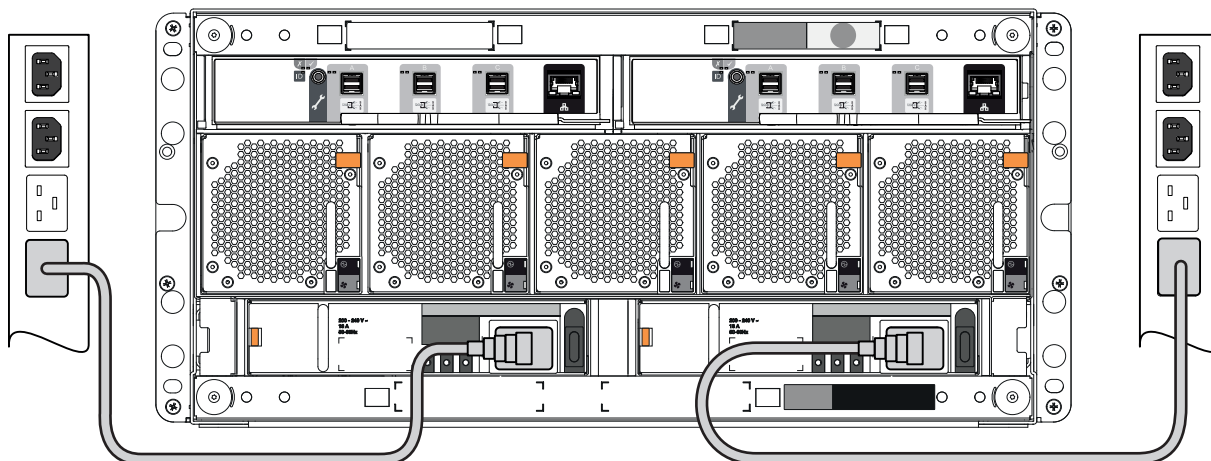



Figure 29 5U power cord routing to independent power distribution units

5. Secure each power cord, using the built-in secure ties on the PSU.
6. Proceed with routing data cables in the next tasks, leaving the power on sequence until after you complete all other cabling tasks and are fully ready to test your connections.

6 Operation of 2U enclosures

 **CAUTION** Only operate the expansion enclosure in a dust-free environment to meet temperature control and airflow requirements.

Before you power on the 2U enclosure, you must take the following actions:

1. Review the installation checklist, confirming the successful completion of the entire sequence.
2. Verify that all drive modules in their carriers (DDICs) are in the correct slots and that you properly engaged them by pressing firmly until each one locked into place on its midplane.
3. Confirm you have met ambient temperature requirements identified in the Environmental Reqs section.
4. Confirm that airflow paths at the front and rear of the enclosure chassis are clear and remain clear.
5. Proceed to the power on task.
6. Access the software management interface to complete your system setup.

Apply power to the 2U enclosure

The 2U enclosure relies on main power provided through separate, independent power distribution. If you lose main power for any reason, the 2U enclosure automatically restarts after power restoration.

 **CAUTION** Adhere to the following electrical safety guidelines:

- During installation, never connect a power cord to a power supply unit (PSU) or power cooling module (PCM) before installing it in the appropriate expansion enclosure slot.
 - Only connect the power cord to power that complies with the product specifications within the specified range, per the hazardous voltage warning label on the PSU or PCM.
 - During service, always remove the PSU or PCM from power before removing the PCM.
-

 **IMPORTANT** Only after you successfully complete the installation checklist can you complete system setup and begin operation of the expansion enclosure.

To apply power to the 2U enclosure:

1. If you removed power to repair the 2U enclosure, begin by facing the rear of the rack cabinet and connect the plug for each of the power to an independent power distribution unit (PDU). The second power cooling module (PCM) provides the first PCM with redundant power.
-

 **IMPORTANT** The expansion enclosure design requires two redundant power cooling modules (PCMs). You must plug each power cord into an independent power distribution unit (PDU) that connects to an uninterruptible power system.

2. Press the power switch to the ON position for each PCM.
3. Facing the front, observe the LEDs on the front panel area and confirm the *Power On* LED is in a steady green state. If it is flashing amber, proceed to "[Hardware installation and configuration issues](#)" on page 57.

Remove power from the 2U enclosure

The 2U enclosure relies on main power provided through separate, independent power distribution. If you lose main power for any reason, the 2U enclosure automatically restarts after power restoration.

You must quiesce all data exchange before removing power to the 2U enclosure.

To remove power from the 2U enclosure:

 **CAUTION** Never remove power from a redundant power cooling module (PCM) when the other PCM has a fault condition, indicated by an amber LED.

1. After you complete the proper shut down of the application and when you are ready to power down the expansion enclosure, face the rear of the rack cabinet and switch off the power for the faulty PCM PSU.
2. Disconnect each power connector from the power distribution unit (PDU).
3. You must wait a minimum of 15 seconds before power cycling the PCM and a minimum of 30 seconds after successful completion of the power on sequence before you attempt to place the PCM in standby or remove power again.

Set the unit identification number

The storage enclosure does not provide a default unit identification (UID) number during initial installation and setup. The enclosure management software contained in the input/output module (IOM) controls how the system uses the UID. For the first power on, the operator's (ops) panel flashes the numeric 00 and the storage enclosure continues its power on sequence, even though it does not have a valid UID. Valid values are 00 to 99.

Once you set a UID for the storage enclosure, the enclosure management software stores that value in the midplane Vital Product Data (VPD) and remains there through power cycles. In instances where the enclosure management software cannot read the VPD, the storage enclosure displays the numeric 00.

If you configure the UID for other purposes, set the value using alternate software methods, rather than the following method.

To set the unit identification number (UID):

1. Press and hold the ops panel input switch above the *Power on* LED for 5 seconds until the left digit flashes.
2. Increment the number with each subsequent press of the input switch until you reach the desired value for that digit.
3. Press and hold the input switch for 5 seconds until the right digit flashes.
4. Increment the number with each subsequent press of the input switch until you reach the desired value for that digit.
5. Press and hold the input switch for 5 seconds to set the UID to the values on the display.
6. (Optional) To clear the UID back to the reserved value of 00, press and hold the input switch for 5 seconds.

Interpret system LEDs

Visual cues provide you with the means to monitor the expansion enclosure and its components and reinforce software messages about system health. Use LEDs throughout the expansion enclosure to determine if there is a critical fault.

The expansion enclosure registers the following states using the identified LED colors.

1. **Green or unlit LED:** Indicates a module is functioning normally
2. **Flashing green or amber LED:** Indicates a non-critical condition

3. **Amber LED:** Indicates a critical fault
4. **Blue LED:** Indicates system component identification, so is not a fault or critical condition

Since an amber fault LED uses fast or slow flashes to cover multiple conditions, this is the priority for simultaneous indications:

Table 3 Fault LED prioritization

Priority	Flash rate	Indication	Description
Top priority	Fast flash (1s on, 1s off)	Identify	Locate the enclosure or module
Priority 2	On	Fault	Fault condition detected
Priority 3	Slow flash (3s on, 1s off)	Logical or non-critical fault	Logical fault or non-critical notification
Lowest priority	Off	No indication	System functioning normally

The front panel area, controller module, and expansion module LEDs require further elaboration.

Interpret 2U12 and 2U24 operator's panel LEDs

The 2U enclosure operator's (ops) panel contains a series of LEDs to reflect system status. You can monitor the ops panel LEDs to determine system status in combination with the user interface content.

In the case of a system fault condition, identified in the state column with an asterisk (*), troubleshoot the fault.

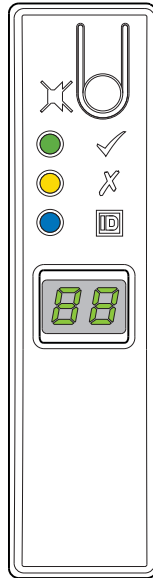

LED	Type	Color	State	Status
	Power on or standby	Green	On	2U enclosure power is on
			Off	2U enclosure power off
	Module fault	Amber	On*	2U enclosure drive module fault, when paired with drive fault LED
				Module fault in rear panel area, when paired with a module fault LED
			Off	2U enclosure functioning properly
	Unit ID (UID)	Blue	Flashing	2U enclosure unit identification (UID) request active
			Off	No UID request is active
	LED display	Green	On	Unit identification value for 2U enclosure

Figure 30 2U12 and 2U24 operator's panel LEDs

Interpret SAS 12Gb/s expansion input/output module LEDs

Input/output modules (IOMs) in an expansion enclosure provide for added system storage. The IOM LEDs reflect host connectivity status and IOM fault conditions.

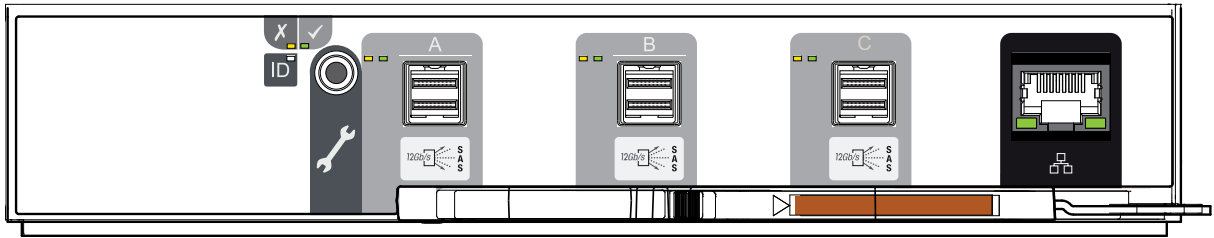

LED	Type	Color	State	Status
	Module fault	Amber	On*	Ops panel undergoing 5s test Rear panel area fault: IOM, fan, PSU Drive module hardware fault, paired with drive module fault LED
			Flashing*	Unknown, invalid, or mixed module type Vital product data (VPD) configuration error or 1°C bus failure
			Off	Rear panel area modules functioning properly
	Power on or standby	Green	On	IOM power is on
		Amber	On	Part of standby sequence as EM comes online
		None	Off	IOM power is off
	Unit identification (UID)	White	On	IOM UID active to locate or identify for service activity
			Off	IOM UID not active
	SAS port	Green	On	Connected, link is up
			Off	Not connected or link is down
		Amber	On*	Critical SAS cable fault
			Fast flash (1s on, 1s off)	SAS UID active
			Slow flash* (3s on, 1s off)	Non-critical SAS cable fault
Off	SAS expansion port functioning properly			
	Ethernet port	Green	On	Connected, link is up
			Off	Not connected or link is down

Figure 31 SAS 12Gb/s expansion input/output module LEDs

7 Operation of 5U enclosures

 **CAUTION** Only operate the expansion enclosure in a dust-free environment to meet temperature control and airflow requirements.

Before you power on the 5U enclosure, you must take the following actions:

1. Review the installation checklist, confirming the successful completion of the entire sequence.
2. Verify that all drive modules in their carriers (DDICs) are in their correct slots and that you properly engaged them by pressing firmly until each one locks into place on its midplane.
3. Confirm you have met ambient temperature requirements identified in "[Technical specifications](#)" on page 95.
4. Confirm that airflow paths at the front and rear of the enclosure chassis are clear and remain clear.
5. Proceed to the power on task.
6. Access the software management interface to complete your system setup.

Apply power to the 5U enclosure

The 5U enclosure relies on main power provided through separate, independent power distribution. If you lose main power for any reason, the 5U enclosure automatically restarts after power restoration.

 **CAUTION** Adhere to the following electrical safety guidelines:

- During installation, never connect a power cord to a power supply unit (PSU) before installing it in the appropriate expansion enclosure slot.
 - Only connect the power cord to power that complies with the product specifications within a range of 200 to 240VAC, per the hazardous voltage warning label on the PSU.
 - During service, always remove the PSU from power by disconnecting the power connector before removal of the PSU.
-

 **IMPORTANT** Only after you successfully complete the installation checklist can you complete system setup and begin operation of the expansion enclosure.

To apply power to the 5U enclosure:

1. If you removed power to repair the 5U enclosure, begin by facing the rear of the rack cabinet and connect the plug for each of the power to an independent power distribution unit (PDU). The second power supply unit (PSU) provides the first PSU with redundant power.

 **IMPORTANT** The expansion enclosure design requires two redundant power supply units (PSUs). You must plug each power cord into an independent power distribution unit (PDU) that connects to an uninterruptible power system.

2. Press the power switch to the ON position for each power supply unit (PSU).
3. Facing the front, observe the LEDs on the front panel area and confirm the *Power On* LED is in a steady green state. If it is flashing amber, proceed to "[Hardware installation and configuration issues](#)" on page 57.

Remove power from the 5U enclosure

The 5U enclosure relies on main power provided through separate, independent power distribution. If you lose main power for any reason, the 5U enclosure automatically restarts after power restoration.

You must quiesce all data exchange before removing power to the 5U enclosure.

To remove power from the 5U enclosure:

 **CAUTION** Never remove power from a redundant power supply unit (PSU) when the other PSU has a fault condition, indicated by an amber LED.

1. After you complete the proper shut down of the application and when you are ready to power down the 5U enclosure, press the power switch to the OFF position for each PSU.
2. Disconnect each power connector from its PSU socket or from the PDU.
3. You must wait a minimum of 15 seconds before power cycling the PSU and a minimum of 30 seconds after successful completion of the power on sequence before you attempt to place the PSU in standby or remove power again.

Set the unit identification number

The storage enclosure does not provide a default unit identification (UID) number during initial installation and setup. The enclosure management software contained in the input/output module (IOM) controls how the system uses the UID. For the first power on, the operator's (ops) panel flashes the numeric 00 and the storage enclosure continues its power on sequence, even though it does not have a valid UID. Valid values are 00 to 99.

Once you set a UID for the storage enclosure, the enclosure management software stores that value in the midplane Vital Product Data (VPD) and remains there through power cycles. In instances where the enclosure management software cannot read the VPD, the storage enclosure displays the numeric 00.

If you configure the UID for other purposes, set the value using alternate software methods, rather than the following method.

To set the unit identification number (UID):

1. Press and hold the ops panel input switch above the *Power on* LED for 5 seconds until the left digit flashes.
2. Increment the number with each subsequent press of the input switch until you reach the desired value for that digit.
3. Press and hold the input switch for 5 seconds until the right digit flashes.
4. Increment the number with each subsequent press of the input switch until you reach the desired value for that digit.
5. Press and hold the input switch for 5 seconds to set the UID to the values on the display.
6. (Optional) To clear the UID back to the reserved value of 00, press and hold the input switch for 5 seconds.

Interpret system LEDs

Visual cues provide you with the means to monitor the expansion enclosure and its components and reinforce software messages about system health. Use LEDs throughout the expansion enclosure to determine if there is a critical fault.

The expansion enclosure registers the following states using the identified LED colors.

1. **Green or unlit LED:** Indicates a module is functioning normally
2. **Flashing green or amber LED:** Indicates a non-critical condition

3. **Amber LED:** Indicates a critical fault
4. **Blue LED:** Indicates system component identification, so is not a fault or critical condition

Since an amber fault LED uses fast or slow flashes to cover multiple conditions, this is the priority for simultaneous indications:

Table 4 Fault LED prioritization

Priority	Flash rate	Indication	Description
Top priority	Fast flash (1s on, 1s off)	Identify	Locate the enclosure or module
Priority 2	On	Fault	Fault condition detected
Priority 3	Slow flash (3s on, 1s off)	Logical or non-critical fault	Logical fault or non-critical notification
Lowest priority	Off	No indication	System functioning normally

The front panel area, controller module, and expansion module LEDs require further elaboration.

Interpret 5U enclosure operator's panel LEDs

The 5U enclosure operator's (ops) panel contains a series of LEDs to reflect system status. You can monitor the ops panel LEDs to determine system status in combination with the user interface content.

In the case of a system fault condition, identified in the state column with an asterisk (*), troubleshoot the fault. See the baseboard management controller (BMC) system event log (SEL) for detailed information.



LED	Type	Color	State	Status	
02	Unit ID	Green	On	Unit identification (UID) of 5U enclosure (0 to 99)	
			Flashing (1s on, 1s off)	SCSI enclosure services (SES) controlled UID or locate active	
✓	Power on or standby	Green	On	5U enclosure power is on	
			Amber	On	5U enclosure has AC power and is on standby as enclosure comes online
			None	Off	5U enclosure AC power is off
X	Module fault	Amber	On*	Ops panel completing 5s test	
				Module fault in rear panel area, when paired with module fault LED	
				Drive fault, when paired with drive fault LED	
			Flashing*	Unknown, invalid, or mixed module types, such as mixed drive modules or PSUs	
			Off	Vital product data (VPD) configuration error or 1°C bus fault	
			Off	5U enclosure rear panel area modules functioning properly	
Cylinder icon	Logical status	Amber	On*	System component hardware fault: drive, cable, or fanout card	
				System component hardware change of status	
				Drive fault caused loss of redundancy	
			Flashing*	System software reports an informational condition for the array, such as a rebuild operation, with corresponding drives registering a fault	
			Off	System component hardware functioning properly, no errors	
Cube icons	Drawer 1, Drawer 2 hardware fault	Amber	On*	Upper, lower drawer hardware fault: drive, cable, or fanout card	
			Flashing (1s on, 1s off)	UID or locate active for Drawer 1, Drawer 2 sideplane or drive	
			Off	Upper, lower drawer hardware functioning properly	

Figure 32 5U84 operator's panel LEDs

Interpret drawer LED panels

Each 5U enclosure drawer bezel contains 2 LED panels to reflect drawer status and activity, 1 for each sideplane. Each sideplane represents a data path within the drawer. You can monitor the drawer LED panels to determine drawer status in combination with the user interface content.

In the case of a fault condition, identified in the state column with an asterisk (*), troubleshoot the fault. If a fault exists on a single data path, only the related LED panel reports the fault, just as it would with a cable module, cable link, or drive faults. See the baseboard management controller (BMC) system event log (SEL) for detailed information.







LED	Type	Color	State	Status
	Power and sideplane OK	Green	On	Drawer power on and sideplane hardware functioning properly
			Off	Power to drawer off
	Drawer module fault	Amber	On*	Drawer module fault condition for drawer sideplane or drive
			Flashing (1s on, 1s off)	Unit identification (UID) or locate active for drawer sideplane or drive
			Off	Drawer modules functioning properly
	Logical status	Amber	On*	Drive hardware fault condition
			Flashing* (3s on, 1s off)	One or more arrays impacted by drive hardware fault conditions
			Off	Drive module hardware functioning properly
	Drawer cable fault	Amber	On*	Cable between rear panel area and drawer fault condition
			Off	Cables functioning properly
	Drawer data activity bar	Green	Flashing (1s on, 1s off)	Segments reflect amount of data activity; greater numbers of segments reflect greater data activity
			Off	No data activity

Figure 33 5U84 drawer LED panel

Interpret SAS 12Gb/s expansion input/output module LEDs

Input/output modules (IOMs) in an expansion enclosure provide for added system storage. The IOM LEDs reflect host connectivity status and IOM fault conditions.

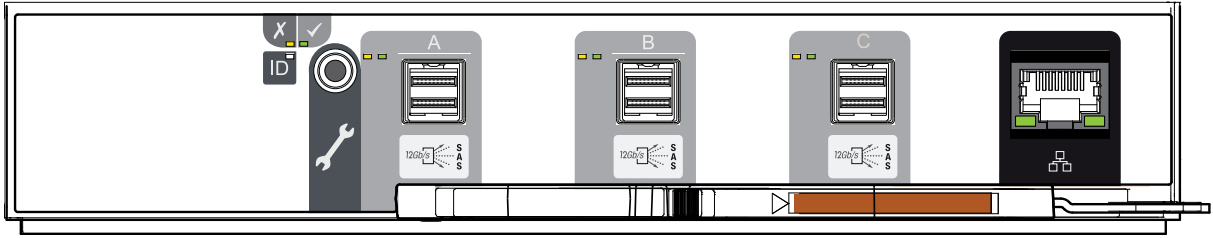

LED	Type	Color	State	Status
	Module fault	Amber	On*	Ops panel undergoing 5s test Rear panel area fault: IOM, fan, PSU Drive module hardware fault, paired with drive module fault LED
			Flashing*	Unknown, invalid, or mixed module type Vital product data (VPD) configuration error or 1°C bus failure
			Off	Rear panel area modules functioning properly
	Power on or standby	Green	On	IOM power is on
		Amber	On	Part of standby sequence as EM comes online
		None	Off	IOM power is off
	Unit identification (UID)	White	On	IOM UID active to locate or identify for service activity
			Off	IOM UID not active
	SAS port	Green	On	Connected, link is up
			Off	Not connected or link is down
		Amber	On*	Critical SAS cable fault
			Fast flash (1s on, 1s off)	SAS UID active
			Slow flash* (3s on, 1s off)	Non-critical SAS cable fault
Off	SAS expansion port functioning properly			
	Ethernet port	Green	On	Connected, link is up
			Off	Not connected or link is down

Figure 34 SAS 12Gb/s expansion input/output module LEDs

8 Hardware installation and configuration issues

The enclosure management interface allows for provisioning, monitoring, and managing the enclosure. It uses the and associated monitoring and control logic, such as the SCSI Enclosure Services (SES) service, or Redfish, to assess and diagnose power, drive modules, and cooling systems. Temperature sensors throughout the enclosure and its components monitor the thermal health of the storage system. If a critical sensor value exceeds a threshold limit, you receive a system notification that requires your attention.

If you encounter any issues during installation or initial configuration, use the topics in this section to assist you in fault isolation and correction.

! **IMPORTANT** Do not use this section for configured systems already interacting with production data. For the kind of assistance you need in such cases, contact Seagate for technical support.

Address initial start-up issues

You must successfully complete the installation tasks in the identified sequence. You must use the power cords provided with the system and install interface cables that meet system requirements.

To address initial start-up issues:

1. Complete the following actions to eliminate POST issues:
 - a. For dual controller configurations, wait a minimum of 10 minutes for each controller to complete synchronization with the other controller and to reach a ready state.
 - b. For single controller configurations, wait a minimum of 2 minutes for the enclosure to reach a ready state.
2. Complete the following actions to eliminate power cord issues during installation:
 - a. Request a replacement for damaged or missing power cords.
 - b. Request a replacement for cords with plugs that do not match your outlets or voltage requirements
 - c. Request a replacement for power cords that are too short to reach a power distribution unit.
3. Use LEDs throughout the enclosure as a means to determine if there is a critical fault. See ["2U12 and 2U24 enclosure fault LEDs" on the next page](#) or ["5U84 enclosure fault LEDs" on page 60](#).
4. Complete the following actions to verify your installation if the host system does not recognize the enclosure:
 - a. Verify the interface cables you connected from the enclosure to each host bus adapter are not damaged, loose, or wired improperly.
 - b. Look for drive or disk group target visibility on the host side.
5. Complete the following actions if the enclosure does not initialize:
 - a. Verify each power cord is properly and securely connected on both ends.
 - b. Reconfirm that the power source used to power the enclosure, is viable, and meets the installation criteria.
 - c. Power cycle the enclosure.
 - d. Examine the input/output module and host system log for errors.

6. Complete the following actions if the enclosure does not report as much capacity as expected:
 - a. Verify you correctly installed the drive modules, and they are all latched to the baseplane connectors.
 - b. Verify all installed drive module carriers display green LEDs, rather than fault LEDs. See ["Replace a 2U enclosure drive module in its carrier" on page 74](#) or ["Replace a 5U enclosure drive module in its carrier" on page 83](#), following replacement procedures for any with fault LEDs.

Interpret storage and expansion enclosure fault LEDs

Throughout the storage and expansion enclosures, steady amber LEDs indicate a fault condition, but flashing indicates a non-critical condition. Some FRUs have more than one fault condition. An asterisk (*) indicates a fault condition.

2U12 and 2U24 enclosure fault LEDs

Visually inspect the front panel area for fault LEDs, then locate the component fault LEDs, based on identified general location, identified on the operator's panel or the drive modules. This is the only option available. The asterisk (*) indicates a fault condition.

Operator's panel fault LEDs

The operator's (ops) panel uses green and amber LEDs to identify various states. Use the amber fault conditions identified on the ops panel to direct you to the fault LEDs on suspect modules. The asterisk (*) indicates a fault condition.

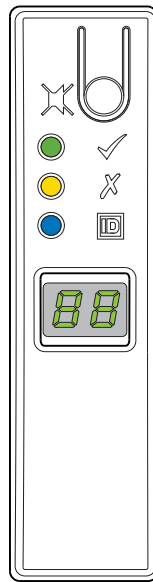

LED	Type	Color	State	Status
	Module fault	Amber	On*	Expansion enclosure rear panel area module fault or temperature issue
			Off	Expansion enclosure rear panel area modules functioning properly

Figure 35 2U12 and 2U24 operator's panel fault LEDs

Drive carrier fault LED

The drive module in its carrier (DDIC) uses an amber LED to identify various states and fault conditions. The asterisk (*) indicates a fault condition.

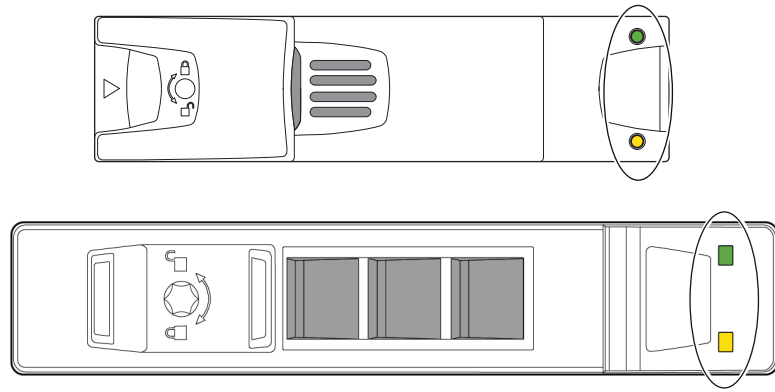

Color	State	Status
Amber	On*	The drive module has a hardware fault, so replace as soon as possible
		The power control circuit has a hardware fault
	Fast flash (1s on, 1s off)	Unit identification (UID) bit is set
	Slow flash* (3s on, 1s off)	Failed array
	Off	Drive is functioning normally
		No AC power is present

Figure 36 2U12 and 2U24 fault LEDs on carrier bezel

Expansion module fault LEDs

The expansion module has several ports, some with independent status LEDs. The amber LEDs listed below are the only ones that provide fault condition status. The asterisk (*) indicates a fault condition.

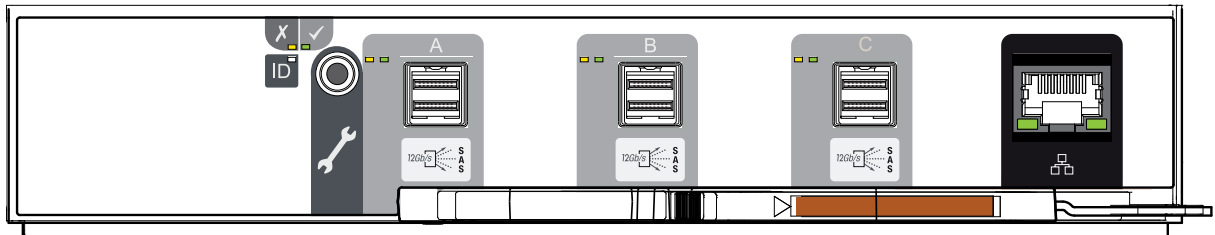



LED	Type	Color	State	Status
	Module fault	Amber	On	Drive link is down
			On*	Expansion enclosure hardware fault
			Fast flash (1s on, 1s off)	Unit identification (UID) bit is set
			Slow flash* (3s on, 1s off)	Expansion enclosure degraded or offline
			Off	Expansion enclosure functioning properly
	SAS expansion port	Amber	On*	Critical SAS cable fault
			Fast flash (1s on, 1s off)	SAS unit identification (UID) active
			Slow flash* (3s on, 1s off)	Non-critical SAS cable fault
			Off	SAS expansion port functioning properly

Figure 37 SAS 12Gb/s expansion module fault LEDs

Power cooling module fault LEDs

The 580W power cooling module (PCM) has 4 LEDs to identify various states. When no LEDs are on, there is no AC power to the PCM. The asterisk (*) indicates a fault condition.

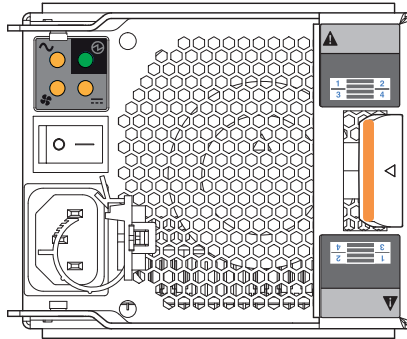

LED					Status
Type	AC fault	PCM OK	Fan fault	DC fault	N/A
Color	Amber	Green	Amber	Amber	
State	Off				AC power not present on either PCM
	On*	Off		On*	AC power not present on this PCM
	Off	On	Off		AC power present, power switch is on; PCM functional
	Off	On	Off	On*	PCM fan speed is out of tolerance
	Off		On*	Off	PCM fan fault
	On	Off	On*		PCM hardware fault: over temperature, over voltage, over current
	Off	Flashing	Off		PCM is in standby mode
	Flashing	Off	Flashing		Firmware update to PCM in progress

Figure 38 Power cooling module fault LEDs

5U84 enclosure fault LEDs

Visually inspect the front panel area for fault LEDs, then locate the component fault LEDs, based on general location identified on the operator's panel or the drawer indicators. This is the only option available. An asterisk (*) indicates a fault condition.

Operator's panel fault LEDs

The operator's (ops) panel uses several green and amber LEDs to identify various states. Use the amber fault conditions identified on the operator's (ops) panel to direct you to the fault LEDs on suspect modules. The asterisk (*) indicates a fault condition.



LED	Type	Color	State	Status
X	Module fault	Amber	On*	Ops panel completing 5s test
				5U enclosure rear panel area module fault: IOM, fan, or PSU when paired with module fault LED
			Flashing*	Drive fault, when paired with drive fault LED
				Unknown, invalid, or mixed module type, such as drive or PSU
Off	VPD configuration error or 1°C bus failure			
Cylinder icon	Logical status	Amber	On*	5U enclosure rear panel area modules functioning properly
				System component hardware fault: drive, cable, or fanout card
			Flashing*	System component hardware change of status
				Drive fault caused loss of redundancy
Off	System software reports an informational condition for the array, such as a rebuild operation, with corresponding drives registering a fault condition			
Cube icon	Drawer 1, Drawer 2 hardware fault	Amber	On*	System component hardware functioning properly
				Upper, lower drawer hardware fault: drive, cable, or fanout card
			Flashing*	Unit ID (UID) or locate is active for Drawer 1, Drawer 2 sideplane or drive
Off	Upper, lower drawer hardware functioning properly			

Figure 39 5U84 operator's panel fault LEDs

Drawer panel fault LEDs

Each drawer contains up to 42 drive modules in their carriers (DDICs) and retains cable connections inside the enclosure chassis. Drawer panel fault LEDs register whether the failure is a hardware failure, a logical failure, or a cabling failure for that drawer or its related components. The asterisk (*) indicates a fault condition.



LED	Type	Color	State	Status
	Drawer module fault	Amber	On*	Component within drawer fault condition ¹ Drive fault ¹
			Flashing*	Unit ID (UID) or locate is active for drawer sideplane or drive
			Off	Drawer modules functioning properly
	Logical fault	Amber	On*	Drive hardware fault condition
			Flashing*	One or more arrays impacted by drive hardware fault conditions
			Off	Drive hardware functioning properly
	Drawer cable fault	Amber	On*	Cable from rear panel to drawer fault condition ²
			Off	Cables functioning properly

¹ If all drives are functioning properly, contact Technical Support for assistance.
² Contact Technical Support for assistance.

Figure 40 5U84 drawer fault LEDs on drawer LED panel

Drive carrier fault LED

The drive module in its carrier (DDIC) uses a single amber fault LED to identify various states. The asterisk (*) indicates a fault condition.



Color	State	Status
Amber	On*	Drive has hardware fault, replace as soon as possible Drive link down
	Fast flash (1s on, 1s off)	Unit identification (UID) or locate is active for drive
	Slow flash* (3s on, 1s off)	Drive in critical condition Failed array
	Off	No AC power present Drive initialization in process Drive quarantined

Figure 41 Drive fault LED on carrier bezel

Expansion module fault LEDs

The expansion module has a number of ports, some with independent status LEDs. The amber LEDs listed below are the only ones that provide fault condition status. The asterisk (*) indicates a fault condition.

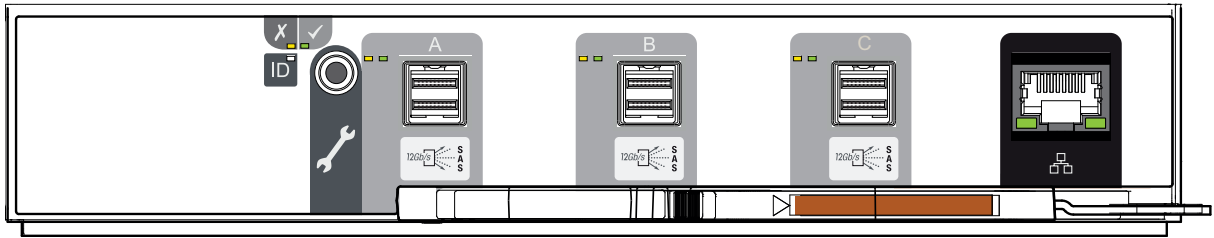



LED	Type	Color	State	Status
	Module fault	Amber	On	Drive link is down
			On*	Expansion enclosure hardware fault
			Fast flash (1s on, 1s off)	Unit identification (UID) or locate is active for expansion module
			Slow flash* (3s on, 1s off)	Expansion module degraded or offline
			Off	Expansion module functioning properly
	SAS expansion port	Amber	On*	Critical SAS cable fault
			Fast flash (1s on, 1s off)	Unit identification (UID) or locate is active for SAS expansion port
			Slow flash* (3s on, 1s off)	Non-critical SAS cable fault
			Off	SAS expansion port functioning properly

Figure 42 SAS 12GB expansion module fault LEDs

Fan cooling module fault LEDs

The fan cooling module (FCM) has a green and an amber fault LED to identify various states. The asterisk (*) indicates a fault condition.

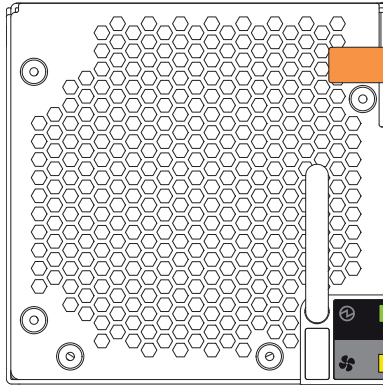

LED	Type	Color	State	Status
	FCM OK	Green	On	FCM hardware functioning properly
			Off*	FCM hardware fault: over temperature, over voltage, over current
	FCM fault	Amber	On*	Fan speed is out of tolerance
			On*	Communication with input/output module (IOM) lost
			Off	FCM hardware functioning properly

Figure 43 Fan cooling module fault LEDs

Power supply unit fault LEDs

Each power supply unit (PSU) has three status LEDs. The asterisk (*) indicates a fault condition.

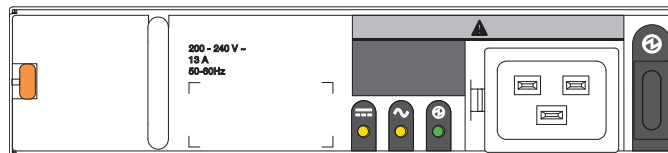

LED				Status
Type	PSU fault	AC fault	PSU OK	N/A
Color	Amber	Amber	Green	
State	Off			AC power not present
	On*		Off	PSU present, but not supplying power
	Flashing		Off	Firmware download to PSU in progress
	Off		On	AC power present, power switch is on, providing power
	Off		Flashing	AC power present, PSU on standby, other PSU providing power
	On*			Communication with input/output module (IOM) lost
	On*	N/A	Off	PSU hardware fault
	On*			PSU alert state or hardware fault: over temperature, over voltage, or over current
	Off	On*	Off	AC power failed, PSU not providing power, other PSU providing power
Off	On*		AC power failed, PSU running on battery	

Figure 44 Power supply unit fault LEDs

Identify 2U enclosure fault conditions

Fault conditions do not necessarily cause the 2U enclosure to cease functioning. Fault conditions do require a system administrator to take an appropriate action to clear the fault condition.

The input/output modules (IOMs) allow you to choose from multiple fault isolation methods. This section provides the basic methodology used to locate faults within a storage system, then identify the affected FRUs.

When performing fault isolation and troubleshooting steps, select the option or options that best suit your site environment. Use of any one of the following options is not mutually exclusive to the use of another option. The order for the options is based on frequency of use.

To identify 2U enclosure fault conditions:

1. Monitor event and alert notifications through your host system interface or your preferred alternate method and based on the notification settings you enable.
 - a. **Event notifications:** The system event logs record all system events and identifies the event type and its severity.
 - b. **Alert notifications:** An alert reports a system fault, registers the type and severity, then tracks its resolution.
2. Alerts fall into three categories, listed in order of severity. Resolve them, moving from most severe to least severe.
 - a. **Critical alerts:** Such alerts require immediate resolution since they may cause a controller module to shut down or place data at risk.
 - b. **Warnings:** Such alerts require immediate attention so you can evaluate the problem and correct it.
 - c. **Informational alerts:** Such alerts neither require immediate attention nor immediate action.
3. Use the command line interface (CLI). If you discover a problem, review the CLI for any recommended actions.
4. Visually inspect front panel area fault LEDs, then locate component fault LEDs, based on LED-identified general location. If a hardware issue prevents access to the CLI, it is the only option available.

Table 5 2U enclosure non-fault conditions

Symptom	Cause	Recommended Action
Operator's panel area LEDs, no fault conditions		
System power, system ID, and host connectivity LEDs with no module or logical fault LEDs	System functioning properly	No action required
Drive module LEDs, no fault conditions		
Amber flashing LED: 1 second on, 1 second off	Drive unit identification (UID) bit is set	No action required
Controller or expansion module LEDs, no fault conditions		
LEDs other than: -IOM amber fault LEDs -SAS port amber fault LEDs	System likely functioning properly	Often, no action required. See " Interpret SAS 12Gb/s expansion input/output module LEDs " on page 55.
PCM LEDs, no fault conditions		
PCM OK amber LED flashing	PCM is in standby mode	No action required

Identify 5U enclosure fault conditions

Fault conditions do not necessarily cause the 5U enclosure to cease functioning. Fault conditions do require a system administrator to take an appropriate action to clear the fault condition.

The input/output modules (IOMs) allow you to choose from multiple fault isolation methods. This section provides the basic methodology used to locate faults within a storage system, then identify the affected FRUs.

When performing fault isolation and troubleshooting steps, select the option or options that best suit your site environment. Use of any one of the following options is not mutually exclusive to the use of another option. The order for the options is based on frequency of use.

To identify 5U enclosure fault conditions:

1. Monitor event and alert notifications through your host system interface.
 - a. **Event notifications:** The system event logs record all system events and identifies the event type and its severity.
 - b. **Alert notifications:** An alert reports a system fault, registers the type and severity, then tracks its resolution.
2. Alerts fall into three categories, listed in order of severity. Resolve them, moving from most severe to least severe.
 - a. **Critical alerts:** Such alerts require immediate resolution, since they may cause a controller module to shut down or place data at risk.
 - b. **Warnings:** Such alerts require immediate attention so you can evaluate the problem and correct it.
 - c. **Informational alerts:** Such alerts neither require immediate attention nor immediate action.
3. Use the command line interface (CLI). If you discover a problem, review the CLI for any recommended actions.
4. Visually inspect front panel fault LEDs, then locate component fault LEDs, based on LED-identified general location. If a hardware issue prevents access to the CLI, it is the only option available.

Table 6 5U enclosure non-fault conditions

Symptom	Cause	Recommended Action
Operator's panel area LEDs, no fault conditions		
System power, system ID, and host connectivity LEDs with no module, logical, or drawer fault LEDs	System functioning properly	No action required.
Drawer panel LEDs, no fault conditions		
Drawer power and sideplane OK LED	System functioning properly	No action required.
Drawer data activity bar		
Drive module LEDs, no fault conditions		
Amber flashing LED: 1 second on, 1 second off	Drive unit identification (UID) bit is set	No action required.
Controller or expansion module LEDs, no fault conditions		
LEDs other than: -IOM amber fault LEDs -SAS port amber fault LEDs	System likely functioning properly	Often, no action required. See "Interpret SAS 12Gb/s expansion input/output module LEDs" on page 55.
FCM LEDs, no fault conditions		
FCM OK amber LED flashing	FCM is in standby mode	No action required.
PSU LEDs, no fault conditions		
PSU OK amber LED flashing	PSU is in standby mode	No action required.

Isolate hardware and connectivity faults

You may occasionally have to isolate a fault related to the enclosure hardware or related to data connections associated with the enclosure. This is particularly true with data paths because of the number of components involved along the data path and the complexity of the interactions. For example, if a host-side data error occurs, it could be caused by any of the involved hardware components. It could be on the host side, such as a faulty host bus adapter (HBA) or switch. It could be on the enclosure side, such as a faulty input/output module (IOM), cable, or connector. It also could be a failure involving more than one of these components.

Gather common installation hardware fault information and isolate the fault using the identified procedure.

△ CAUTION When you suspect a drive module or connection is the fault, halt all input and output operations to the disk group or groups from all hosts as a data protection precaution. Make sure your regularly scheduled backup is good and that you conduct another backup at the time of failure as an additional data protection precaution.

To isolate hardware and connectivity faults associated with the enclosure:

1. Complete the following actions to gather fault information:
 - a. Examine host application or operating system logs for fault identification.
 - b. Examine system logs from both IOMs for errors, such as log and status output for fault identification.
 - c. Use system alerts to help narrow the fault to an area of the enclosure.
 - d. Visually inspect the operator's panel LEDs. A hardware fault LED indicates there is a hardware issue and a logical fault LED indicates there could be a drive or disk group issue.
 - e. Access the identified location, then look for an amber fault LED to help identify a faulty module.
 - f. If you cannot find a fault in any of the listed areas, the fault most likely lies outside the enclosure.
2. Isolate the fault to one of the components in the enclosure. There can be a significant number of components interacting to create a viable data path, each potentially creating an issue. For example, if a host-side data error occurs, it could be hardware, such as the IOM, a faulty cable, or possibly the data host.
3. Proceed to the next section and take the recommended corrective action. This may mean obtaining a replacement FRU of the same type before replacing the faulty module.

Isolate system application faults

System application faults generally fall into two categories: drive faults or input/output module (IOM) faults.

To isolate system application faults:

1. Determine the cause of a SAS port host-side fault.
 - a. Halt all input and output from the host to the enclosure.
 - b. Verify there is no activity on the SAS host port activity LED for that data port. If there is, halt all applications that access the enclosure.
 - c. Reseat the host cable after inspecting it for damage to the cable and connectors.
 - d. After reconnection, if the fault condition persists, move the host cable to a port with a tested, good link status to isolate the issue to the external data path or the IOM data port.
 - e. After reseating the host cable, if the fault condition persists, replace the host cable with a tested, good one.
 - f. Verify that the host bus adapter (HBA) is fully seated and the PCI slot is powered on and functioning.
 - g. If the fault condition persists, reseat the HBA.
 - h. If the SAS host port activity LED still flashes amber, replace the HBA and reconnect the cable.
 - i. If the fault condition persists, replace the IOM.
2. For still unaddressed issues, proceed to the next section and take the recommended corrective action, based on the symptom. This may mean obtaining a replacement FRU of the same type before replacing the faulty module.

Take corrective action for 2U enclosures

After you follow the process above and isolate the fault to an area of the 2U enclosure or to a particular module, use the following chart to determine the type of corrective action you should take.

Table 7 2U enclosure corrective action for fault conditions







Symptom	Cause	Recommended action
Ops panel fault LED for drive module faults		
<p><i>Module fault</i> LED is on</p>  <p>and a drive carrier fault LED is on</p> 	<p>A fault condition related to the hardware in the front or rear panel areas</p>	<ol style="list-style-type: none"> Inspect the LEDs on the drive carriers for these conditions: <ul style="list-style-type: none"> Both drive carrier fault LEDs are off. A drive carrier fault LED is on, not flashing. Select one of the following actions: <ul style="list-style-type: none"> Reseat the drive module in its carrier (DDIC). If both LEDs are off, verify that the DDIC is fully inserted, the latch is fully engaged, and the 2U enclosure is powered on. If the drive carrier fault LED is on, narrow the fault to the drive module, the carrier, a connection, or both. Scan the 2U enclosure event log for specific fault information and follow recommended actions. If the above actions do not resolve the fault, replace the faulty drive module or carrier as soon as you have a replacement.
Ops panel fault LEDs that identify rear panel area faults		
<p><i>Module fault</i> LED is on</p>  <p>and an input/output module (IOM) fault LED is on</p> 	<p>A fault condition related to the IOM hardware in the rear panel area</p>	<ol style="list-style-type: none"> Restart the IOM with a command. Confirm the redundant IOM properly functions. Select one of the following actions: <ul style="list-style-type: none"> If both IOMs have fault conditions, follow shut down instructions and power off the 2U enclosure by removing power to both PCMs. Do not power on until after you successfully replace them both. If one IOM has a fault, remove power, wait 1 minute, then reset the IOM . If the IOM still fails, and the failure is related to a host port, follow the steps associated with system application faults below. If the IOM still fails, remove the power cord, wait 1 minute, then reseat the IOM. If the IOM still fails, replace it within the specified 8 minutes with a new one. If a newly installed IOM still fails, remove it, inspect connections for bent pins, reinstall it, then check the event log for errors.
<p><i>Module fault</i> LED is on</p>  <p>and one or more power cooling module (PCM) fault LEDs are on</p> 	<p>A fault condition related to the PCM</p>	<ol style="list-style-type: none"> Verify AC mains connections to the PCM are live. Confirm the redundant PCM properly functions. Select one of the following actions: <ul style="list-style-type: none"> If both PCMs still fail, follow shut down instructions and power off the 2U enclosure by removing power to both PCMs. Do not power on until after you successfully replace them both. If only one PCM still fails, either power cycle the PCM and wait 1 minute or remove the power cord, wait 1 minute, then reseat the power cord. If the PCM still fails, remove it, wait 1 minute, then reseat it. If the PCM still fails, replace it within the specified 10 minutes. If the power fault condition persists, contact your vendor for support.
Thermal monitoring and control		

Table 7 2U enclosure corrective action for fault conditions (continued)

Symptom	Cause	Recommended action
<p>Module fault LED is on</p>  <p>and fault LEDs for both PCMs are on</p>	<p>Internal temperature exceeds the present threshold for the enclosure</p>	<ol style="list-style-type: none"> 1. Confirm you have met ambient temperature requirements identified in the <i>Environmental Requirements</i> section and that the air flow moves from the front to the rear of the enclosure. 2. Remove the PCM with the fault, wait 1 minute, then reseal it. 3. Determine if only one of the PCMs failed or is in the process of failing. Verify all fans run at a similar RPM. If the impellers of a fan turn more than 2K RPM slower than the other fan, replace the PCM. 4. Follow instructions related to increases in fan speed, identified below. 5. Shut down the 2U enclosure and investigate before continuing.
<p>Increased fan speed is greater than 12K RPM when the ambient temperature is below 23°C (73.4°F). Factors such as ambient temperature, number of installed drives, and altitude each influence fan speed.</p>	<p>Increases in fan speed are associated with reaching a thermal threshold as the first stage of the thermal control process. If you encounter fan speeds greater than 12K RPM when the ambient temperature is below 23°C (73.4°F), the likely cause is reduced airflow through the system.</p>	<ol style="list-style-type: none"> 1. Confirm all hardware is properly installed, including blanks. <p>Recommendation: Visually inspect hardware during installation or replacement to fully engage or secure it.</p> 2. Look for airflow restrictions at the front and rear of the 2U enclosure. <p>Recommendation: If a rack door blocks airflow by more than 60%, make sure it has a front minimum gap of 75mm (3 in) and a rear minimum gap of 152mm (6 in).</p> 3. Confirm there are no restrictions based on contaminants, such as dust. <p>Recommendation: Improve removal of contaminants and keep area clean.</p> 4. Look for excessive re-circulation of heated air from the rear to the front of the 2U enclosure. <p>Recommendation: Avoid mounting in rack cabinets that are fully enclosed.</p> 5. Verify temperature is within product specifications. See <i>Standards and regulations</i>. <p>Recommendation: Reduce the ambient temperature in the room.</p>

Take corrective action for 5U enclosures

After you follow the process above and isolate the fault to an area of the 5U enclosure or to a particular module, use the following chart to determine the type of corrective action you should take.

Table 8 5U enclosure corrective action for fault conditions

Symptom	Cause	Recommended action
Operator's (ops) panel fault LED for logical faults		
<p>Logical fault LED is on</p> 	<p>A fault condition related to the system application logic</p>	<ol style="list-style-type: none"> 1. Scan the enclosure event log for specific information for the fault. 2. For system application faults, see <i>Isolate system application faults</i>. 3. If the above actions do not resolve the fault, isolate the fault to the failing component identified in the rear panel area and follow the instructions below.

Table 8 5U enclosure corrective action for fault conditions (continued)









Symptom	Cause	Recommended action
<p>Module fault LED is on</p>  <p>and Drawer logical fault LED is on</p> 	<p>A fault condition related to the hardware or system application logic</p>	<ol style="list-style-type: none"> Inspect the drawer panel for a fault amber LED that is on. Inspect the LEDs on the carriers in the drawer for these conditions: <ul style="list-style-type: none"> The carrier LED is off. The carrier fault amber LED is on, not flashing. Select one of the following actions: <ul style="list-style-type: none"> If the carrier LED is off, verify that the carrier is fully inserted, the latch is fully engaged, and the 5U enclosure is powered on. If the fault LED is on, narrow the fault to the drive module, a connection, or both. Inspect the LEDs on the drawer sideplanes. If a sideplane fault condition exists, contact your support representative. Scan the enclosure event log for specific fault information and follow recommended actions. If the above actions do not resolve the fault, replace the faulty drive module or carrier as soon as you have a replacement.
<p>Ops panel fault LEDs for hardware faults</p>		
<p>Module fault LED is on</p>  <p>and Drawer module fault LED is on</p>  <p>and drive carrier fault LED is on</p> 	<p>A fault condition related to the hardware in the related drawer</p>	<ol style="list-style-type: none"> Inspect the drawer panel for a fault amber LED that is on. Inspect the LEDs on the drive carriers in the drawer for these conditions: <ul style="list-style-type: none"> The drive carrier fault LED is off. The drive carrier fault LED is on, not flashing. Select one of the following actions: <ul style="list-style-type: none"> If the drive carrier fault LED is off, verify that the carrier is fully inserted, the latch is fully engaged, and the 5U enclosure is powered on. If the drive carrier fault LED is on, narrow the fault to the drive module, a connection, or both. Scan the enclosure event log for specific fault information and follow recommended actions. If the above actions do not resolve the fault, replace the faulty drive module or carrier as soon as you have a replacement.
<p>Module fault LED is on</p>  <p>and Logical fault LED is on</p>  <p>and drive carrier fault LED is on</p> 	<p>A fault condition related to the hardware in the related drawer</p>	<ol style="list-style-type: none"> Inspect the drawer panel for a fault amber LED that is on. Inspect the LEDs on the drive carriers in the drawer for these conditions: <ul style="list-style-type: none"> The drive carrier fault LED is off. The drive carrier fault LED is on, not flashing. Select one of the following actions: <ul style="list-style-type: none"> If the drive carrier fault LED is off, verify that the carrier is fully inserted, the latch is fully engaged, and the 5U enclosure is powered on. If the drive carrier fault LED is on, narrow the fault to the drive module, a connection, or both. Scan the enclosure event log for specific fault information and follow recommended actions. If the above actions do not resolve the fault, replace the faulty drive module or carrier as soon as you have a replacement.

Table 8 5U enclosure corrective action for fault conditions (continued)















Symptom	Cause	Recommended action
<p>Drawer 1 fault or Drawer 2 fault LED is on</p>  -or-  <p>and Cable fault LED is on</p> 	<p>A fault condition related to the cabling to the related drawer</p>	<p>The cabling between the drawer and the midplane failed. Contact your vendor for assistance.</p>
<p>Ops panel fault LEDs that identify rear panel area faults</p>		
<p>Module fault LED is on</p>  <p>and an input/output module (IOM) fault LED is on</p> 	<p>A fault condition related to the IOM hardware in the rear panel area</p>	<ol style="list-style-type: none"> Restart the IOM with a command. Confirm the redundant IOM properly functions. Select one of the following actions: <ul style="list-style-type: none"> If both IOMs have fault conditions, follow shut down instructions and power off the system enclosure by removing power to both PSUs. Do not power on until after you successfully replace both IOMs. If one IOM has a fault, remove power, wait 1 minute, then reset the IOM . If the IOM still fails, and the failure is related to a host port, follow the steps associated with system application faults below. If the IOM still fails, remove the power cord, wait 1 minute, then reseal the IOM. If the IOM still fails, replace it within the specified 8 minutes with a new one. If installing a new IOM still fails, remove it, inspect connections for bent pins, reinstall it, then check the event log for errors.
<p>Module fault LED is on</p>  <p>and a fan cooling module (FCM) fault LED is on</p> 	<p>A fault condition related to the system fan</p>	<ol style="list-style-type: none"> Select one of the following actions: <ul style="list-style-type: none"> For instances where both FCM fault LEDs are on, see the <i>Thermal Monitoring</i> section of this table. If only one fan is failing, remove the FCM, wait 1 minute, then reseal. If the FCM is still failing, replace it within the specified 10 minutes.
<p>Module fault LED is on</p>  <p>and a PSU fault LED is on</p>  -or- 	<p>A fault condition related to the PSU, such as a power fault condition</p>	<ol style="list-style-type: none"> Verify AC mains connections to the PSU are live. Confirm the redundant PSU is properly functioning. Select one of the following actions: <ul style="list-style-type: none"> If both are failing, follow shut down instructions and power off the system enclosure by removing power to both PSUs. Do not power on until after you successfully replace them both. If only one PSU is failing, remove the power cord, wait 1 minute, then reseal the power cord. If the PSU is still failing, remove it, wait 1 minute, then reseal it. If the PSU is still failing, replace it within the specified 6 minutes. If the power fault condition persists, contact Seagate for support.

Table 8 5U enclosure corrective action for fault conditions (continued)

Symptom	Cause	Recommended action
<p>Module fault LED is on</p>  <p>and IOM fault LED is on</p>  <p>-or-</p>	<p>A fault condition related to the hardware in the rear panel area</p>	<ol style="list-style-type: none"> Restart the expansion module with a command.. Confirm the redundant IOM module is properly functioning. Select one of the following actions: <ul style="list-style-type: none"> If both have fault conditions, follow shut down instructions and power off the system enclosure by removing power to both PSUs. Do not power on until after you successfully replace both IOM enclosure modules. If only one IOM module fails, remove power, wait 1 minute, then reset the drive module. If the IOM module still fails, and the failure is related to a host port, follow the steps associated with system application faults below. If the IOM module still fails, remove the power cord, wait 1 minute, then reseal the IOM. If the IOM module still fails, replace it within the specified 10 minutes with a new one. If a new installed IOM module still fails, remove it, inspect connections for bent pins, reinstall it, then check the event log for errors.
<p>Thermal monitoring and control</p>		
<p>Module fault LED is on</p>  <p>and a PSU fault LED is on</p>  <p>-or-</p>	<p>Internal temperature exceeds the present threshold for the 5U enclosure</p>	<ol style="list-style-type: none"> Confirm you have met ambient temperature requirements identified in the Environmental Requirements section and that the air flow moves from the front to the rear of the 5U enclosure. Confirm you fully closed both main bay and auxiliary bay covers so latches fully engage. Determine if one of the PCMs failed or is in the process of failing. Verify all fans are running at a similar RPM. If the impellers of a fan turn more than 2K RPM slower than the other fan, replace the PCM. Follow instructions related to increases in fan speed, identified below. Shut down the 5U enclosure and investigate before continuing.
<p>Increased fan speed is greater than 12K RPM when the ambient temperature is below 23°C (73.4°F). Factors such as ambient temperature, number of installed drives, and altitude each influence fan speed.</p>	<p>Increases in fan speed are associated with reaching a thermal threshold as the first stage of the thermal control process. If you encounter fan speeds greater than 12K RPM when the ambient temperature is below 23°C (73.4°F), the likely cause is reduced airflow through the system.</p>	<ol style="list-style-type: none"> Confirm all hardware is properly installed, all drives are level and latched, and both drawers are fully closed and latched. <p>Recommendation: Visually inspect hardware during installation or replacement to fully engage or secure it.</p> Look for airflow restrictions at the front and rear of the 5U enclosure. <p>Recommendation: If a rack door blocks airflow by more than 60%, make sure it has a front minimum gap of 75mm (3 in) and a rear minimum gap of 152mm (6 in).</p> Confirm there are no restrictions based on contaminants, such as dust. <p>Recommendation: Improve removal of contaminants and keep area clean.</p> Look for excessive re-circulation of heated air from the rear to the front of the 5U enclosure. <p>Recommendation: Avoid mounting in rack cabinets that are fully enclosed.</p> Verify temperature is within product specifications. See Standards and regulations. <p>Recommendation: Reduce the ambient temperature in the room.</p>

9 In-service field maintenance for 2U enclosures

You may service the identified 2U enclosure FRUs and still maintain continuous operation during the replacement, but with two very important qualifiers:

- You must determine whether your system allows for continuous operation during service replacement of the 2U enclosure drive modules in their carriers (DDICs) without interrupting access to enclosure file systems.
- You must complete the replacement in the allotted time, replacing only one FRU at a time. The 2U enclosure design provides for redundancy, so the loss of a single FRU does not impact functionality for a limited time.

The tasks identified in this chapter first cover FRUs in the drawers, followed by FRUs accessible from the rear panel area. It is essential you adhere to all safety precautions when servicing 2U enclosure FRUs.

CAUTION When performing maintenance on the expansion enclosure or its components:

- Observe the caution label affixed to each drive module or FRU prior to handling or replacing it.
- Do not remove a defective FRU until you have its functional replacement ready for insertion.

To adhere to safety precautions when replacing a FRU in 2U enclosure:

1. Replace any defective FRU with a fully operational one as soon as possible.
2. Replace any defective FRU within the identified replacement time to minimize air loss and maintain optimum cooling within the 2U enclosure.

Table 9 2U enclosure time limits for FRU replacement

Defective FRU	Replacement time limit
Front panel area	
Drive, LFF or SFF, in carrier (DDIC)	5 minutes
Rear panel area	
Power cooling module (PCM)	5 minutes
Input/output module (IOM)	5 minutes
Attachments	
Rackmount rail kit	N/A
Cable kits: Standard HD mini-SAS to HD mini-SAS (SF-8644)	N/A
AC power cord, compatible	N/A

3. Prevent electrostatic discharge from damaging the 2U enclosure or its components.
 - a. Keep a static-protected work surface clear of clutter, including plastic, vinyl, and foam.
 - b. Transport and store FRUs in static-safe containers.
 - c. Keep FRUs in their containers until reaching a clear, static-protected work surface.
 - d. Always wear a grounded ESD wrist strap that meets a minimum 1 megohm ($\pm 10\%$) resistance standard and that is snug against your skin.
 - e. Use heel straps, toe straps, or boot straps on both feet to ground to your conductive floor or dissipating floor mat or use a portable field service kit with a grounded, static-dissipating work mat.
 - f. Use conductive field service tools.

- g. When removing a FRU, immediately place it in anti-static packaging.
- h. Avoid touching pins, leads, or circuitry.

Replace a 2U enclosure drive module in its carrier

The operator's (ops) panel registers either a logical fault or a hardware fault or both. The drive module in its carrier (DDIC) uses an amber LED to identify various states and fault conditions. The asterisk (*) indicates a fault condition.

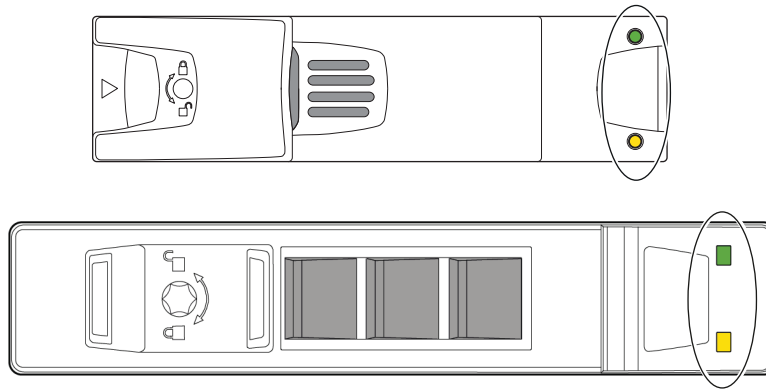

Color	State	Status
Amber	On*	The drive module has a hardware fault, so replace as soon as possible
		The power control circuit has a hardware fault
	Fast flash (1s on, 1s off)	Unit identification (UID) bit is set
	Slow flash* (3s on, 1s off)	Failed array
	Off	
		No AC power is present

Figure 45 2U12 and 2U24 fault LEDs on carrier bezel

An important feature of the 2U enclosure design is redundancy. The 2U enclosure will maintain continuous operation during the replacement of a single DDIC, if it is within the time limit of 5 minutes, since opening a drawer to remove a DDIC significantly reduces airflow in the enclosure.

CAUTION If you remove any FRU while the expansion enclosure is powered up, you must replace it with a tested, good spare within the allotted time for that FRU. If you do not replace the FRU and, when applicable, fully close the related drawer within the identified time limit, you void the product warranty and the expansion enclosure might overheat, causing equipment failure and possible data loss.

CAUTION Do not remove covers from any FRU. There is a danger of electric shock inside. Return the FRU to your supplier for repair.

Drives in their carriers (DDICs) are hot-swappable, but you must replace the DDIC with one of the same type and with an equal or greater capacity. The steel carrier provides thermal conduction, radio frequency, electromagnetic induction, and physical protection. For this task, treat the drive carrier and its installed drive as a single FRU.

To replace a 2U enclosure drive module in its carrier:

1. Complete the following actions to remove a faulty DDIC:
 - a. Facing the front of the 2U enclosure, locate the DDIC with a fault condition.
 - b. Using a thumb and forefinger, squeeze the carrier release latch to release the connection to the midplane.
 - c. Grasping the carrier handle, pull it outward approximately 25mm (1 in) and wait for 30 seconds.

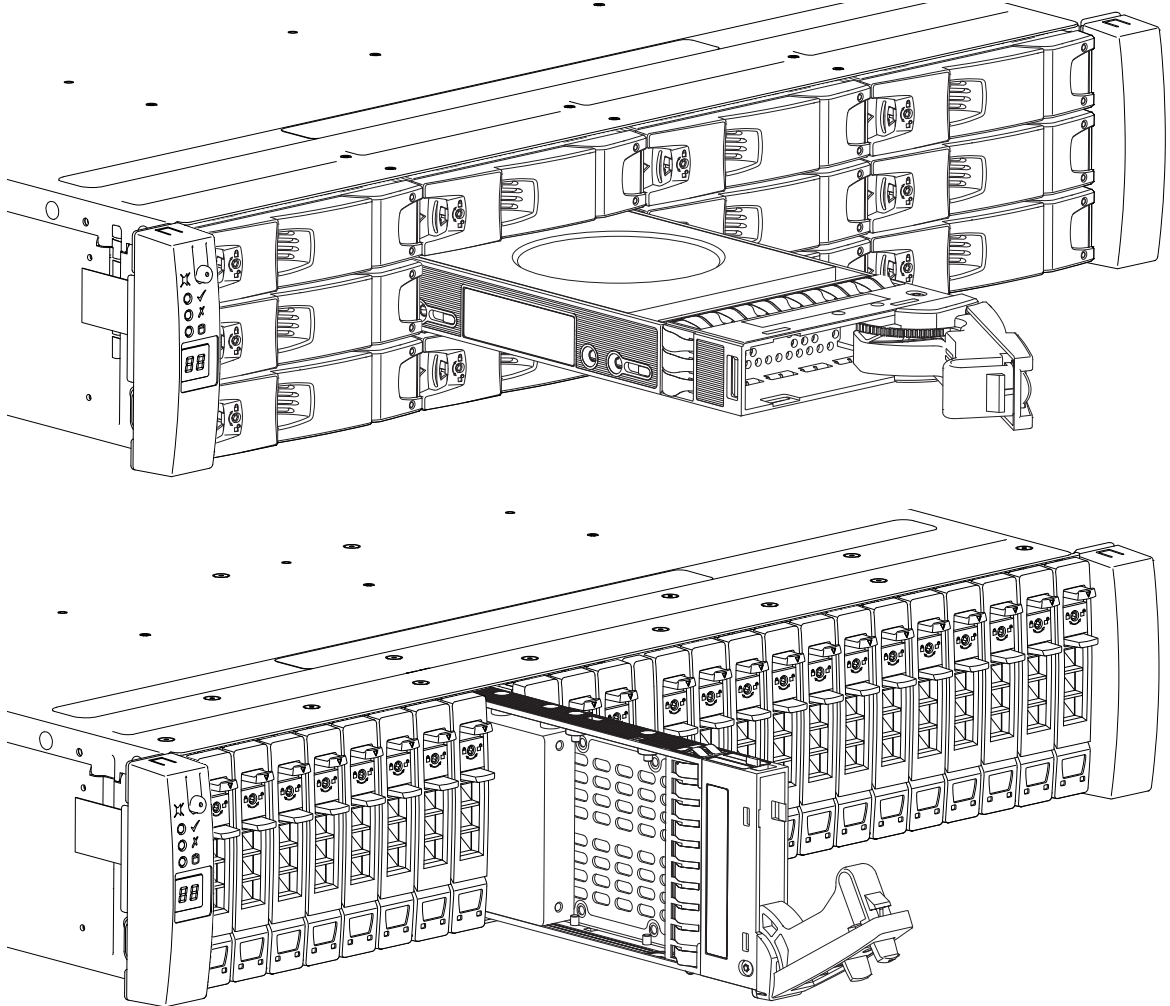

Figure 46 Removal of 2U12 and 2U24 drive in carrier

- d. Use one hand to support the weight of the DDIC and the other to pull the handle outward to fully withdraw the DDIC.
 - e. Place it in a static-protected location.
2. Complete the following actions to replace it with a tested, good DDIC:

- a. Using a thumb and forefinger, squeeze the carrier release latch to release the carrier handle.

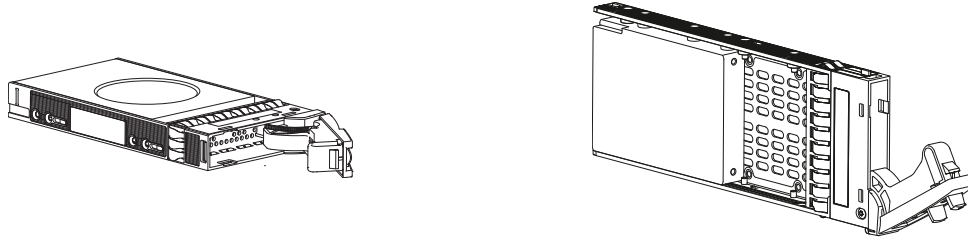

Figure 47 Replacement with open 2U12 and 2U24 carrier handle

- b. Use one hand to support the weight of the DDIC and the other to holding it against the bottom of the slot.
 - c. Slide the carrier inward until the cam lever of the handle is flush with the chassis.
 - d. Firmly press the handle closed until you hear an audible click as it engages the midplane and locks in place.
3. Confirm that the DDIC fault condition LED is off and the operator's (ops) panel is clear of any fault conditions.

Replace a 2U enclosure input/output module

Each input/output module (IOM) receives the flow of data managed by the host system. Each IOM provides a very specialized, solutions-specific interaction that depends on your system configuration and software implementation, including SAS zoning, failover and failback procedures, and multipath procedures.

An important feature of the 2U enclosure design is redundancy. The 2U enclosure will maintain continuous operation during the replacement of a single IOM, as long as it is within the time limit of 5 minutes, since removal of an IOM significantly reduces airflow in the 2U enclosure.

CAUTION If you remove any FRU while the expansion enclosure is powered up, you must replace it with a tested good spare within the allotted time for that FRU. If you do not replace the FRU within the identified time limit, you void the product warranty and the expansion enclosure might overheat, causing equipment failure and possible data loss.

CAUTION Do not remove covers from any FRU. There is a danger of electric shock inside. Return the FRU to your supplier for repair.

The IOM has a number of ports, each with independent status LEDs. Those items in the state column with an asterisk (*) indicate a fault condition.

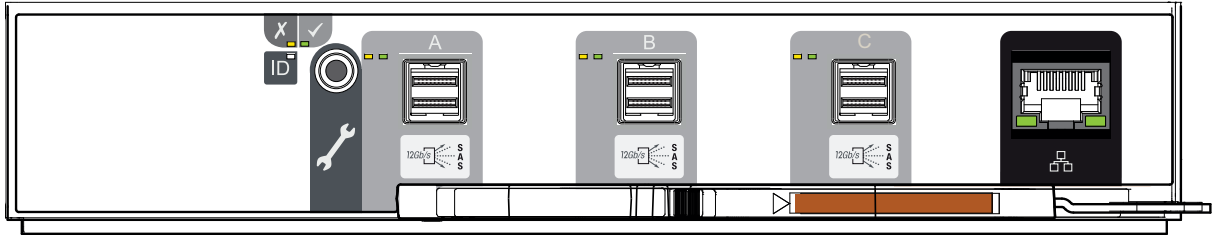





LED	Type	Color	State	Status
	Module fault	Amber	On*	Ops panel undergoing 5s test
				Rear panel area fault: IOM, fan, PSU, when paired with IOM fault LED
				Drive module hardware fault, paired with drive module fault LED
			Flashing*	Unknown, invalid, or mixed module type
			Off	Vital product data (VPD) configuration error or 1°C bus failure
			Off	Rear panel area modules functioning properly
	Power on or standby	Green	On	IOM power is on
		Amber	On	Part of standby sequence as IOM comes online
		None	Off	IOM power is off
	Unit identification (UID)	White	On	IOM UID active to locate or identify for service activity
			Off	IOM UID not active
	SAS port	Green	On	Connected, link is up
			Off	Not connected or link is down
		Amber	On*	Critical SAS cable fault
			Fast flash (1s on, 1s off)	SAS UID active
			Slow flash* (3s on, 1s off)	Non-critical SAS cable fault
Off	SAS expansion port functioning properly			
	Ethernet port	Green	On	Connected, link is up
			Off	Not connected or link is down

Figure 48 SAS 12Gb/s expansion input/output module LEDs

To replace a 2U enclosure input/output module:

1. Complete the following actions to remove the faulty IOM:
 - a. Facing the rear of the 2U enclosure, grasp the IOM release latch between thumb and forefinger, then squeeze together to release the latch and handle.

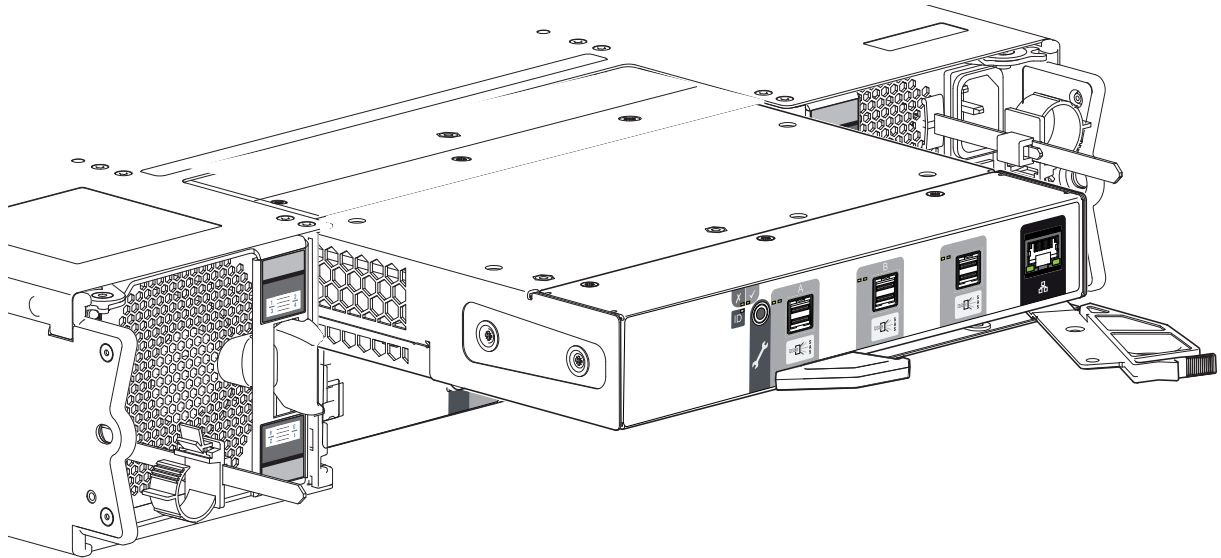

Figure 49 Input/output module removal, upper

- b. Pull the handle outward to lever the IOM away from the midplane.
- c. Use one hand to support the weight of the IOM and the other to gently withdraw the IOM from its slot.
- d. Place it in a static-protected location.
2. Complete the following actions to replace it with a tested good IOM:
 - a. Examine the tested good IOM to make sure it is undamaged with pins that are straight, not bent.

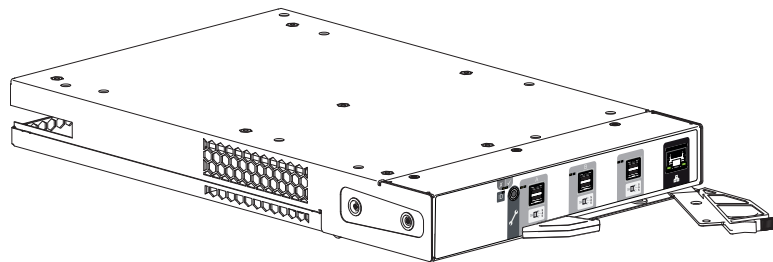

Figure 50 Replacement input/output module

- b. Facing the rear of the 2U enclosure, orient the IOM with the open latch identically to the one you just removed.
- c. Use one hand to support the weight of the IOM and the other to guide it into the empty IOM slot.
- d. Exerting even pressure to the center, gently press it against the midplane until the latch closes and it locks in place.
3. After verifying the connectors are all undamaged, reconnect all cables as they were connected before.
4. Verify that the LED is lit green on the replaced IOM after properly inserting and seating it in the empty slot.
5. Facing the front of the 2U enclosure, verify that the **Power On** LED is green and there are no fault conditions.

Replace a 2U power cooling module

Each auto-ranging power cooling module (PCM) provides power and cooling to the 2U enclosure modules and components. The power supply portion of the PCM provides power to the 2U enclosure within 100V to 240V AC at 50Hz to 60Hz. The PCM uses standard industrial wiring with line-to-neutral or line-to-line power connections.

CAUTION Never remove power from a power cooling module if the partner power cooling module amber LED is lit.

The 580W AC PCM input voltage range is from 100V to 240V AC with an input frequency of 50Hz to 60 Hz. Each PCM uses 4 LEDs to identify various states. When no LEDs are on, there is no AC power to the PCM. The asterisk (*) indicates a fault condition.

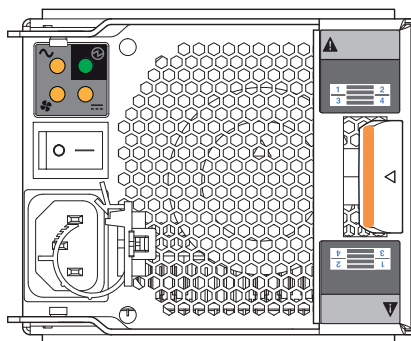

LED					Status
Type	AC fault	PCM OK	Fan fault	DC fault	N/A
Color	Amber	Green	Amber	Amber	
State	Off				AC power not present on either PCM
	On*	Off		On*	AC power not present on this PCM
	Off	On	Off		AC power present, power switch is on; PCM functional
	Off	On	Off	On*	PCM fan speed is out of tolerance
	Off		On*	Off	PCM fan fault
	On	Off	On*		PCM hardware fault: over temperature, over voltage, over current
	Off	Flashing	Off		PCM is in standby mode
	Flashing	Off	Flashing		Firmware update to PCM in progress

An important feature of the 2U enclosure design is redundancy. The 2U enclosure will maintain continuous operation during the replacement of a single PCM, as long as it is within the time limit of 5 minutes, since removal of a PCM significantly reduces airflow in the enclosure.

CAUTION Use only power cords supplied in the installation kit or those that meet product specifications.

CAUTION Adhere to power source and power connection requirements to avoid harm to equipment.

- Only connect the power cooling module (PCM) to power sources that comply with product specifications and labels.
- Always remove all power connections before you remove a PCM from the storage or expansion enclosure.

CAUTION Do not remove covers from any FRU. There is a danger of electric shock inside. Return the FRU to your supplier for repair.

CAUTION If you remove any FRU while the expansion enclosure is powered up, you must replace it with a tested, good spare within the allotted time for that FRU. If you do not replace the FRU and, when applicable, fully close the related drawer

△ within the identified time limit, you void the product warranty and the expansion enclosure might overheat, causing equipment failure and possible data loss.

To replace a power cooling module:

1. Retrieve the new PCM in its static-protected container, ready to immediately replace the faulty one.
2. Complete the following actions to remove the faulty PCM:
 - a. After you complete the proper shut down of the application and when you are ready to power down the expansion enclosure, face the rear of the rack cabinet and switch off the power for the faulty PCM.
 - b. Disconnect each power connector from the power distribution unit (PDU).
 - c. Release the PCM power cord from its secure tie, and then disconnect the power cord from the PCM connector.
 - d. Release and pivot the latch of each PCM to the open position.
 - e. Use one hand to support the weight of the PCM and the other to gently withdraw the PCM.

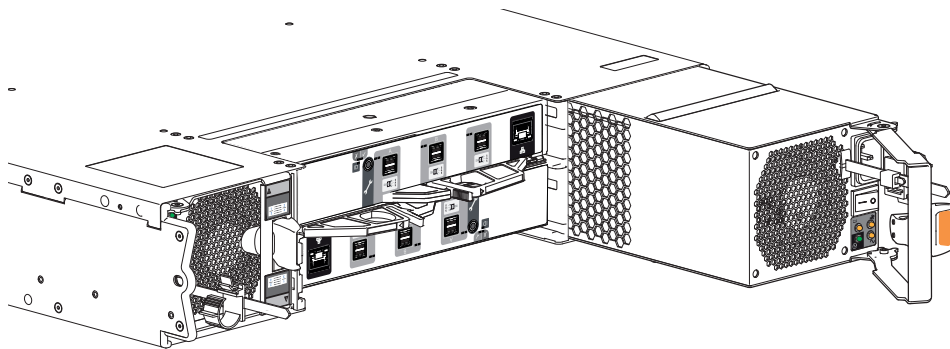

Figure 51 Power cooling module removal

- f. Temporarily store the PCM in a static-protected environment.
3. Complete the following actions to install a tested good PCM:
 - a. Orient the new PCM with the open latch to the outside of the chassis opening.

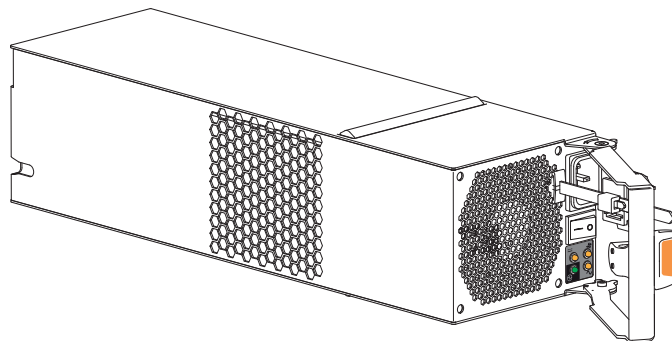

Figure 52 Replacement power cooling module

- b. Use one hand to support the weight of the PCM and the other to guide it into the empty PCM slot.
 - c. Exerting even pressure to the center, gently press inward until it connects with the midplane.
 - d. Swing the latch closed until it locks in place.
 - e. Reconnect the power cord, and then tighten the secure tie around it.

4. Verify that the *PCM OK* LED is lit green on the replaced PCM after properly inserting and seating it in the empty slot.
5. Facing the front of the expansion enclosure, verify that the *Power On* LED is green and there are no fault conditions.

10 In-service field maintenance for 5U enclosures

You may service the identified 5U enclosure FRUs and still maintain continuous operation during the replacement, but with two very important qualifiers:

- You must determine whether your system allows for continuous operation during service replacement of the 5U enclosure drive modules in their carriers (DDICs) without interrupting access to enclosure file systems.
- You must complete the replacement in the allotted time, replacing only one FRU at a time. The 5U enclosure design provides for redundancy, so the loss of a single FRU does not impact functionality for a limited time.

The tasks identified in this chapter first cover FRUs in the drawers, followed by FRUs accessible from the rear panel area. It is essential you adhere to all safety precautions when servicing 5U enclosure FRUs.

CAUTION When performing maintenance on the expansion enclosure or its components:

- Observe the caution label affixed to each drive module or FRU prior to handling or replacing it.
- Do not remove a defective FRU until you have its functional replacement ready for insertion.

To adhere to safety precautions when replacing a FRU in the 5U enclosure:

1. Replace any defective FRU with a fully operational one as soon as possible.
2. Replace any defective FRU within the identified replacement time to minimize air loss and maintain optimum cooling within the 5U enclosure.

Table 10 5U enclosure time limits for FRU replacement

Defective FRU	Replacement time limit
Drawers	
Drive, LFF or SFF, in carrier (DDIC)	7 minutes, including drawer closure
Rear panel area	
Fan cooling module (FCM)	7 minutes
Power supply unit (PSU)	7 minutes
Input/output module (IOM)	7 minutes
Attachments	
Rackmount rail kit	N/A
Cable kits: Standard HD mini-SAS to HD mini-SAS (SF-8644)	N/A
AC power cord, compatible	N/A

3. Prevent electrostatic discharge from damaging the 5U enclosure or its components.
 - a. Keep a static-protected work surface clear of clutter, including plastic, vinyl, and foam.
 - b. Transport and store FRUs in static-safe containers.
 - c. Keep FRUs in their containers until reaching a clear, static-protected work surface.
 - d. Always wear a grounded ESD wrist strap that meets a minimum 1 megohm ($\pm 10\%$) resistance standard and that is snug against your skin.
 - e. Use heel straps, toe straps, or boot straps on both feet to ground to your conductive floor or dissipating floor mat or use a portable field service kit with a grounded, static-dissipating work mat.

- f. Use conductive field service tools.
- g. When removing a FRU, immediately place it in anti-static packaging.
- h. Avoid touching pins, leads, or circuitry.

Replace a 5U enclosure drive module in its carrier

The operator's (ops) panel registers either a logical fault or a drawer hardware fault or both. You must locate a faulty drive in its carrier (DDIC) within the related drawer by its amber fault condition LED.



Color	State	Status
Amber	On*	Drive has hardware fault, replace as soon as possible
		Drive link down
	Fast flash (1s on, 1s off)	Unit identification (UID) or locate is active for drive
	Slow flash* (3s on, 1s off)	Drive in critical condition
		Failed array
Off	Off	No AC power present
		Drive initialization in process
		Drive quarantined

Figure 53 Drive fault LED on carrier bezel

An important feature of the 5U enclosure design is redundancy. The 5U enclosure will maintain continuous operation during the replacement of a single DDIC, if it is within the time limit of 7 minutes, since opening a drawer to remove a DDIC significantly reduces airflow in the enclosure.

CAUTION If you remove any FRU while the expansion enclosure is powered up, you must replace it with a tested, good spare within the allotted time for that FRU. If you do not replace the FRU and, when applicable, fully close the related drawer within the identified time limit, you void the product warranty and the expansion enclosure might overheat, causing equipment failure and possible data loss.

CAUTION Do not remove covers from any FRU. There is a danger of electric shock inside. Return the FRU to your supplier for repair.

The steel carrier provides thermal conduction, radio frequency, electro-magnetic induction, and physical protection. For this task, treat the drive carrier and its installed drive as a single FRU.

To replace a 5U enclosure drive module in its carrier:

1. Complete the following actions to open the related drawer:
 - a. Facing the front of the 5U enclosure, determine which drawer has a fault condition by the fault LEDs on the ops panel and drawer panels.



Figure 54 Operator's panel



Figure 55 Drawer panel

- b. If the anti-tamper lock is engaged, use a T20 Torx driver to unlock both drawer pull handles.
- c. Simultaneously press both drawer latches inward and hold them there while exerting even outward pressure until all three rows are visible and the drawer slide latch locks in the open position.

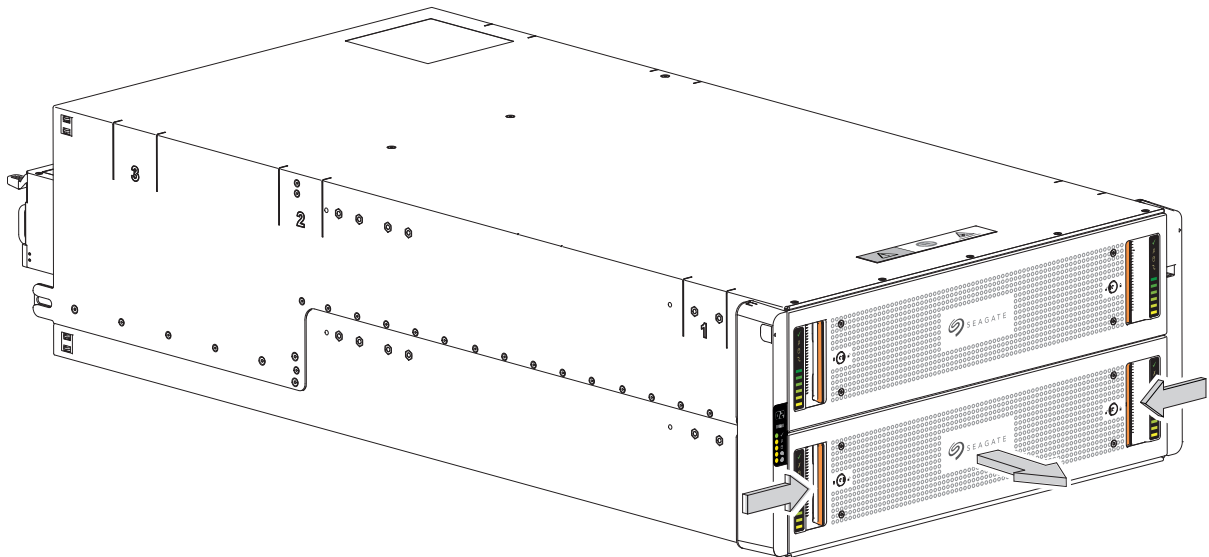

Figure 56 Drawer release and access

- d. Stop when the drawer rails engage the safety lock latches as the drawer reaches the open position, so that you can access all three rows of DDICs.
2. Complete the following actions to remove a faulty DDIC:

- a. Locate the DDIC with a fault condition.

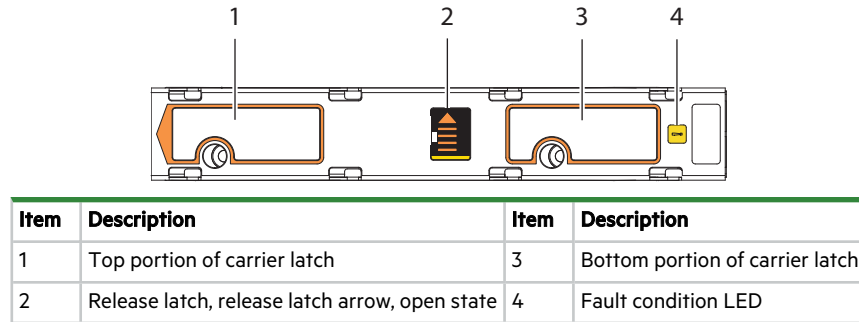

Figure 57 Carrier latch features

- b. Using a thumb, press the DDIC release latch arrow to the right to release the DDIC from its seated position.
- c. Grasping the top of the carrier, pull it upwards until it clears its drawer slot.

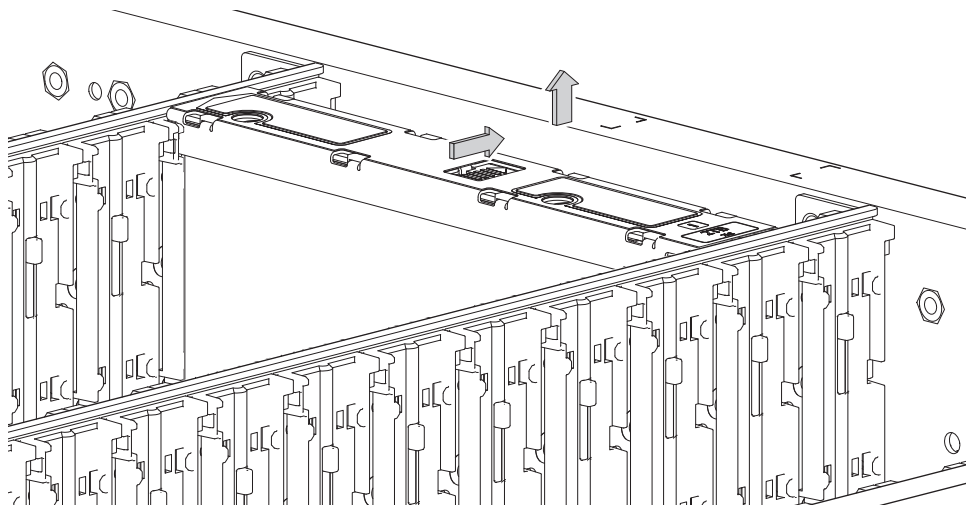

Figure 58 Removal of drive in its carrier

- d. Place it in a static-protected location.
3. Complete the following actions to replace it with a tested, good DDIC:
 - a. Select a new DDIC, orient it so the LED is towards the drawer front, and the release latch arrow towards the rear.
 - b. Align the carrier with the empty drawer slot, then lower it fully into the slot.

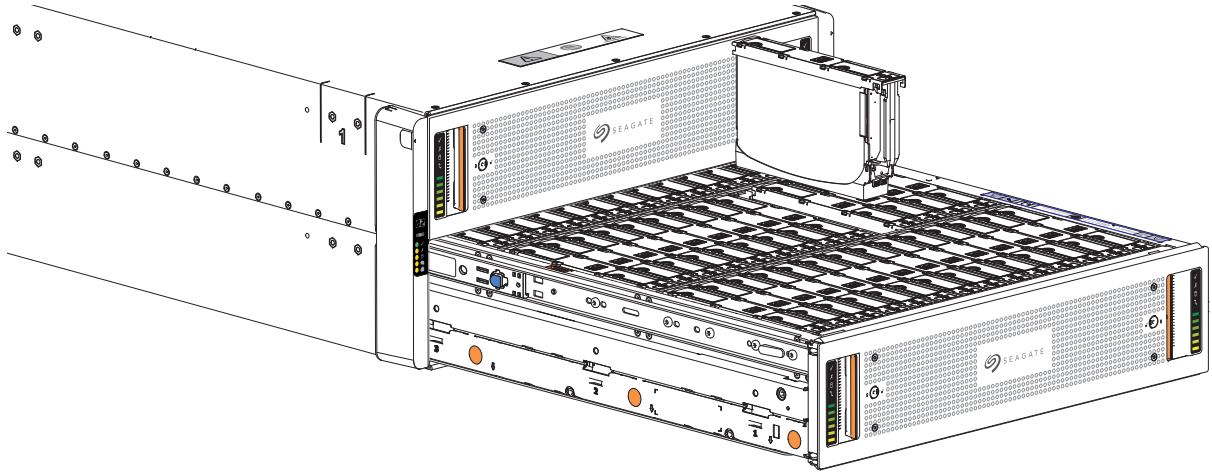

Figure 59 Replacement of drive in its carrier

- c. Push the DDIC down until the top is flush with the top of the slot.
- d. While holding it against the bottom of the slot, slide the top latch toward the rear of the drawer until it locks into place and the DDIC release latch locks.



Figure 60 Release latch open and unlocked



Figure 61 Release latch properly locked

- e. Verify that all drives are at the same level and all DDIC release latches are properly locked.

CAUTION Do not proceed to close the drawer unless all DDICs are in a fully locked position or DDIC height can inhibit or completely prevent drawer access once you close it.

- f. Confirm that the DDIC fault condition LED is off.

4. Complete the following actions to close the related drawer:
 - a. Press and hold the safety lock latches with the blue touchpoint at the front of both extended drawer slide rails.

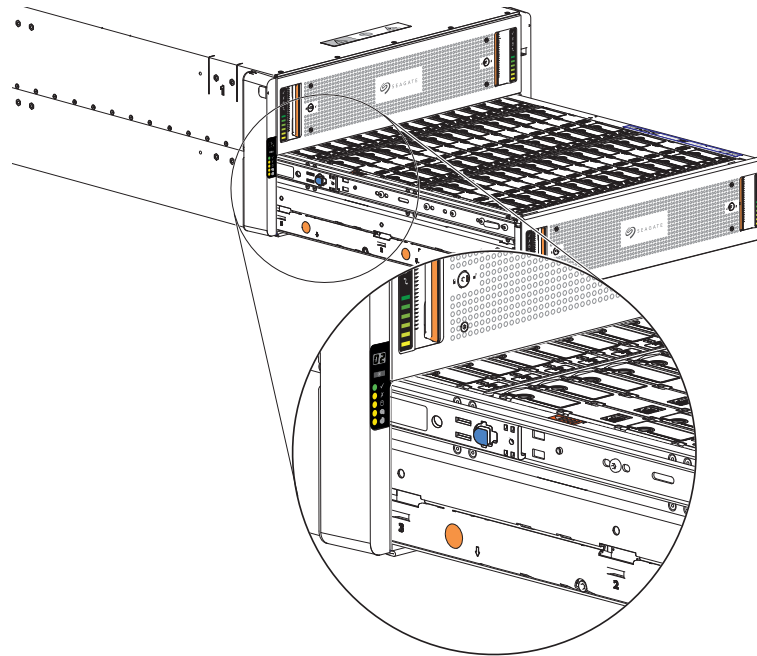

Figure 62 Safety lock to release left drawer slide rail of lower drawer

- b. Pressing simultaneously inward, begin sliding the drawer back into place until the safety lock clears the opening.
 - c. Placing the heels of both palms against the face of the drawer near the anti-tamper locks, exert even inward pressure until the drawer is almost flush with the rack ear flanges.
 - d. Simultaneously press inward and hold both drawer pull handles as you push the drawer closed until it fully latches.
5. Verify that the fault LED on the replaced DDIC is off after properly inserting and seating it in the empty slot.
6. Facing the front of the 5U enclosure, verify that the *Power On* LED is green and there are no fault conditions.

Replace a 5U enclosure input/output module

Both input/output modules (IOMs) manage the flow of data to and from the 5U enclosure. Each IOM provides a very specialized, solutions-specific interaction that depends on your system configuration and software implementation, including SAS zoning, failover and failback procedures, and multipath procedures.

An important feature of the 5U enclosure design is redundancy. The 5U enclosure will maintain continuous operation during the replacement of a single IOM as long as it is within the time limit of 7 minutes, since removing a IOM significantly alters airflow in the 5U enclosure.

CAUTION If you remove any FRU while the expansion enclosure is powered up, you must replace it with a tested good spare within the allotted time for that FRU. If you do not replace the FRU within the identified time limit, you void the product warranty and the expansion enclosure might overheat, causing equipment failure and possible data loss.

CAUTION Do not remove covers from any FRU. There is a danger of electric shock inside. Return the FRU to your supplier for repair.

The IOM has a number of ports, each with independent status LEDs. Those items in the state column with an asterisk (*) indicate a fault condition.

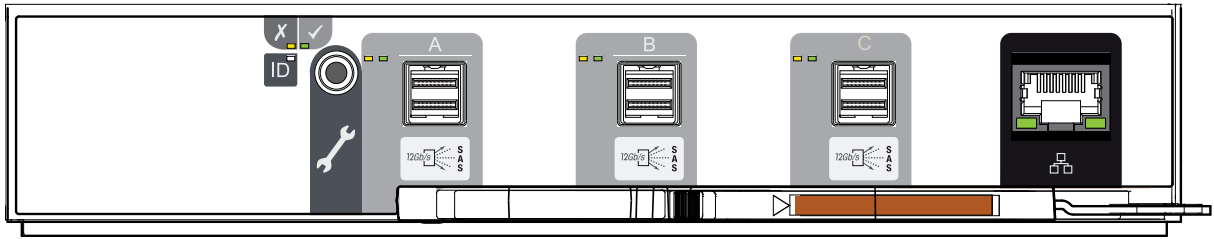

LED	Type	Color	State	Status
	Module fault	Amber	On*	Ops panel undergoing 5s test
			Flashing*	Rear panel area fault: IOM, fan, PSU
				Drive module hardware fault, paired with drive module fault LED
				Unknown, invalid, or mixed module type
Off	Vital product data (VPD) configuration error or 1°C bus failure			
	Power on or standby	Green	On	Rear panel area modules functioning properly
		Amber	On	IOM power is on
		None	Off	Part of standby sequence as EM comes online
	Unit identification (UID)	White	On	IOM power is off
			Off	IOM UID active to locate or identify for service activity
	SAS port	Green	On	Connected, link is up
			Off	Not connected or link is down
		Amber	On*	Critical SAS cable fault
			Fast flash (1s on, 1s off)	SAS UID active
			Slow flash* (3s on, 1s off)	Non-critical SAS cable fault
			Off	SAS expansion port functioning properly
	Ethernet port	Green	On	Connected, link is up
			Off	Not connected or link is down

Figure 63 SAS 8Gb/s input/output module LEDs

To replace a 5U enclosure input/output module:

1. Complete the following actions to remove the faulty IOM :
 - a. Facing the rear of the 5U enclosure, carefully remove all IOM connections.
 - b. Grasp the IOM release latch between thumb and forefinger, then squeeze together to release the latch and handle.

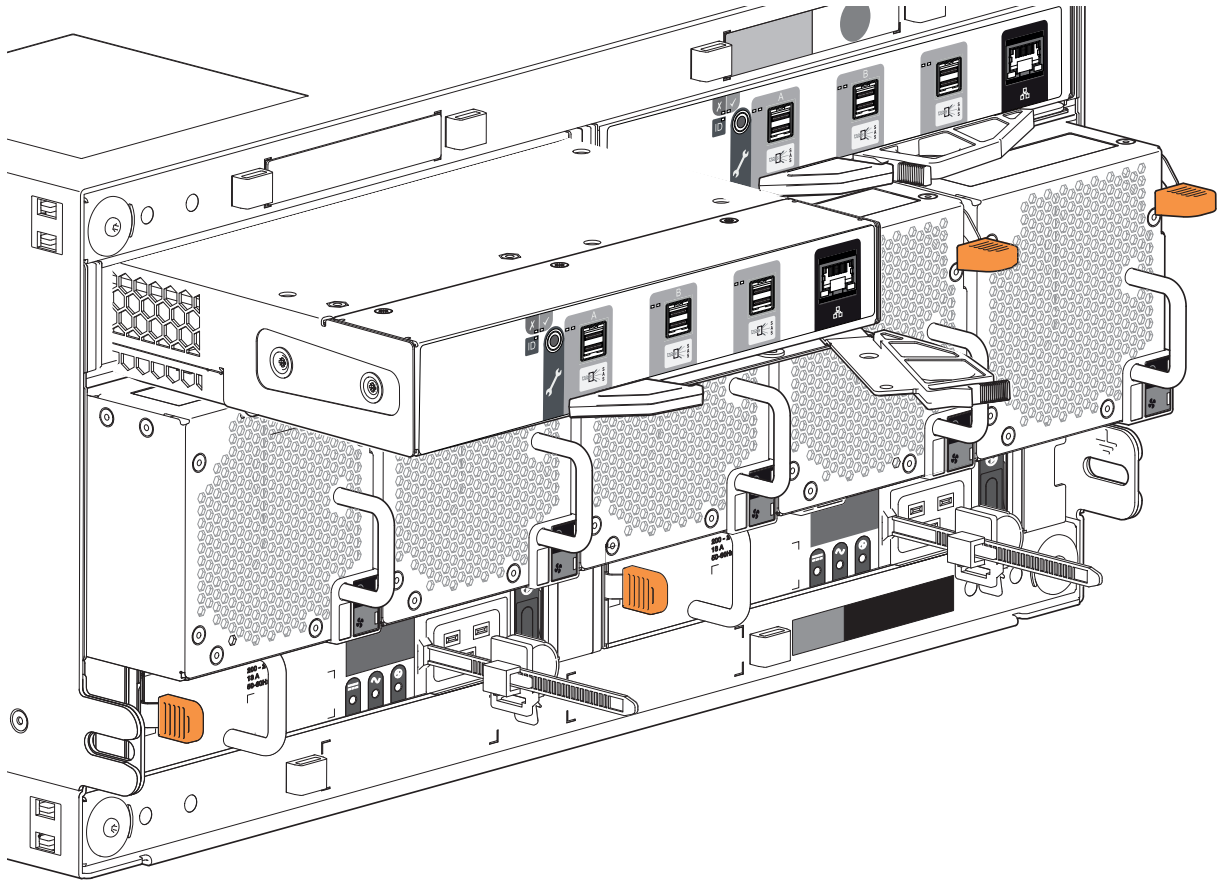

Figure 64 Input/output module removal, left

- c. Pull the handle outward to lever the IOM away from the midplane.
 - d. Use one hand to support the weight of the IOM and the other to gently withdraw the IOM from its slot.
 - e. Place it in a static-protected location.
2. Complete the following actions to replace it with a tested good IOM:
 - a. Examine the tested good IOM to make sure it is undamaged with pins that are straight, not bent.

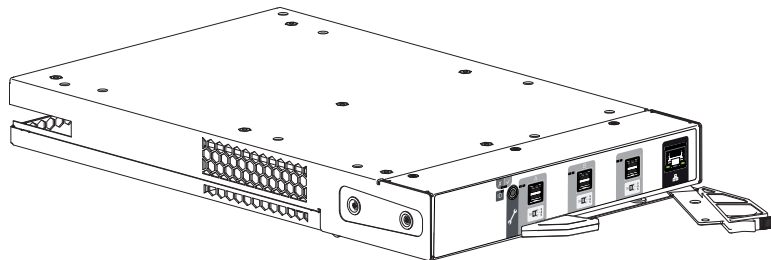

Figure 65 Replacement input/output module

- b. Facing the rear of the 5U enclosure, orient the IOM with the open latch identically to the one you removed.
 - c. Use one hand to support the weight of the IOM and the other to guide it into the empty IOM slot.
 - d. Exerting even pressure to the center, gently press it against the midplane until the latch closes and locks in place.
3. After verifying the connectors are all undamaged, reconnect all cables as they were connected before.

4. Verify that the LED is lit green on the replaced IOM after properly inserting and seating it in the empty slot.
5. Facing the front of the 5U enclosure, verify that the *Power On* LED is green and there are no fault conditions.

Replace a 5U fan cooling module

Fan cooling modules (FCMs) provide cooling to the 5U enclosure modules and components. Each fan cooling module (FCM) has a green and an amber fault LED to identify various states. The asterisk (*) indicates a fault condition.

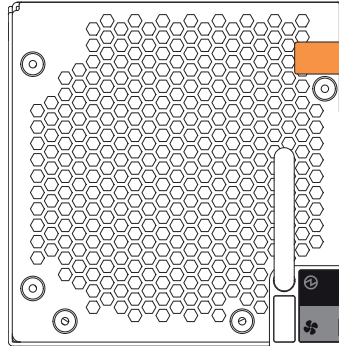



LED	Type	Color	State	Status
	FCM OK	Green	On	FCM hardware functioning properly
			Off*	FCM hardware fault
	FCM fault	Amber	On*	Fan speed is out of tolerance
				Communication with input/output module (IOM) lost
			Off	FCM hardware functioning properly

Figure 66 Fan cooling module fault LEDs

An important feature of the 5U enclosure design is redundancy. The 5U enclosure will maintain continuous operation during the replacement of a single FCM, if it is within the time limit of 7 minutes, since removal of an FCM significantly reduces airflow in the enclosure.

CAUTION If you remove any FRU while the expansion enclosure is powered up, you must replace it with a tested, good spare within the allotted time for that FRU. If you do not replace the FRU and, when applicable, fully close the related drawer within the identified time limit, you void the product warranty and the expansion enclosure might overheat, causing equipment failure and possible data loss.

CAUTION Do not remove covers from any FRU. There is a danger of electric shock inside. Return the FRU to your supplier for repair.

To replace a fan cooling module:

1. Retrieve the new FCM in its static-protected container, ready to access and use the new FCM immediately upon removal of the faulty one.
2. Complete the following actions to remove the faulty FCM:
 - a. Facing the rear of the rack cabinet, press downward to release the FCM latch.
 - b. Use one hand to support the FCM's weight and the other to gently withdraw the FCM all the way from its slot.

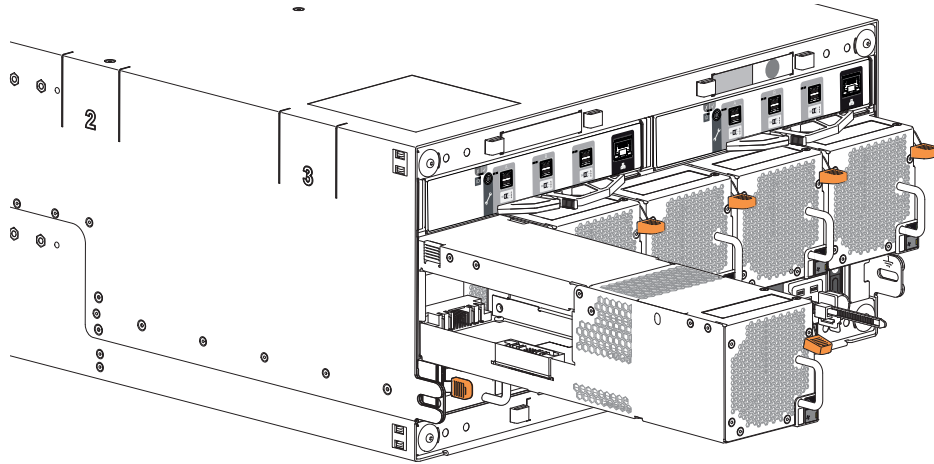

Figure 67 Fan cooling module removal

- c. Place it in a static-protected location.
- 3. Complete the following actions to replace the faulty FCM with a tested, good one:
 - a. Orient the new FCM with the latch to the right.

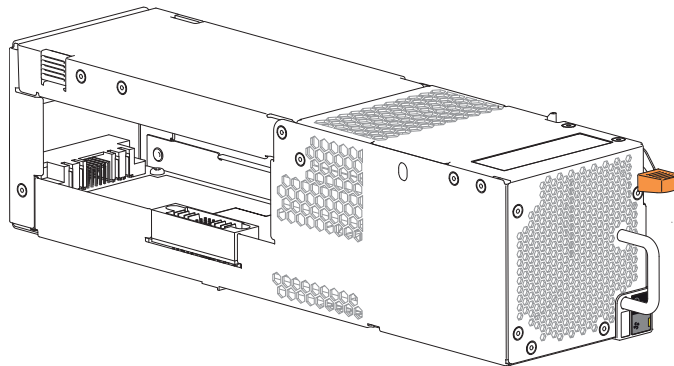

Figure 68 Replacement fan cooling module

- b. Use one hand to support the weight of the FCM and the other to guide it into the empty FCM slot.
- c. Exerting even pressure to the center, gently press inward until it connects with the midplane and it locks in place.
- 4. Verify the *FCM OK* LED is lit green on the replaced FCM after properly inserting and seating it in the empty slot.
- 5. Facing the front of the 5U enclosure, verify that the *Power On* LED is green and there are no fault conditions.

Replace a 5U power supply unit

Both power supply units (PSUs) provide power to the 5U enclosure within 200V to 240V AC at 50Hz to 60Hz. Each PSU has three status LEDs. The asterisk (*) indicates a fault condition.

CAUTION Never remove power from a power supply unit if the partner power supply unit amber LED is lit.

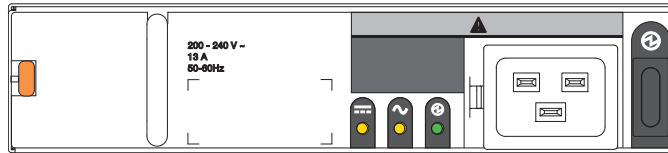

LED				Status
Type	PSU fault	AC fault	PSU OK	N/A
Color	Amber	Amber	Green	
State	Off			AC power not present
	On*		Off	PSU present, but not supplying power
	Flashing		Off	Firmware download to PSU in progress
	Off		On	AC power present, power switch is on, providing power
	Off		Flashing	AC power present, PSU on standby, other PSU providing power
	On*			Communication with input/output module (IOM) lost
	On*		N/A	PSU hardware fault
	On*		Off	PSU alert state or hardware fault: over temperature, over voltage, or over current
	Off	On*		AC power failed, PSU not providing power, other PSU providing power
	Off	On*		AC power failed, PSU running on battery

Figure 69 Power supply unit fault LEDs

An important feature of the 5U enclosure design is redundancy. The enclosure will maintain continuous operation during the replacement of a single PSU, if it is within the time limit of 7 minutes, since removal of a PSU significantly reduces airflow in the 5U enclosure.

CAUTION Use only power cords supplied in the installation kit or those that meet product specifications.

CAUTION Adhere to power source and power connection requirements to avoid harm to equipment.

- Only connect the power supply unit (PSU) to power sources that comply with product specifications and labels.
 - Always remove all power connections before you remove a PSU from the storage or expansion enclosure.
-

CAUTION If you remove any FRU while the expansion enclosure is powered up, you must replace it with a tested, good spare within the allotted time for that FRU. If you do not replace the FRU and, when applicable, fully close the related drawer within the identified time limit, you void the product warranty and the expansion enclosure might overheat, causing equipment failure and possible data loss.

CAUTION Do not remove covers from any FRU. There is a danger of electric shock inside. Return the FRU to your supplier for repair.

To replace a power supply unit:

1. Retrieve the new PSU in its static-protected container, ready to access and use the new PSU immediately upon removal of the faulty one.

2. After you complete the proper shut down of the application and when you are ready to power down the expansion enclosure, face the rear of the rack cabinet and switch off the power for the faulty PSU.
3. Disconnect each power connector from the power distribution unit (PDU).
4. Complete the following actions to remove the faulty PSU:
 - a. Release the PSU power cord from its secure tie, and then disconnect the power cord from the PSU connector.
 - b. Press the PSU release latch to the right to release the PSU from the midplane.
 - c. Use one hand to support the weight of the PSU and the other to pull the handle outward and withdraw the PSU.

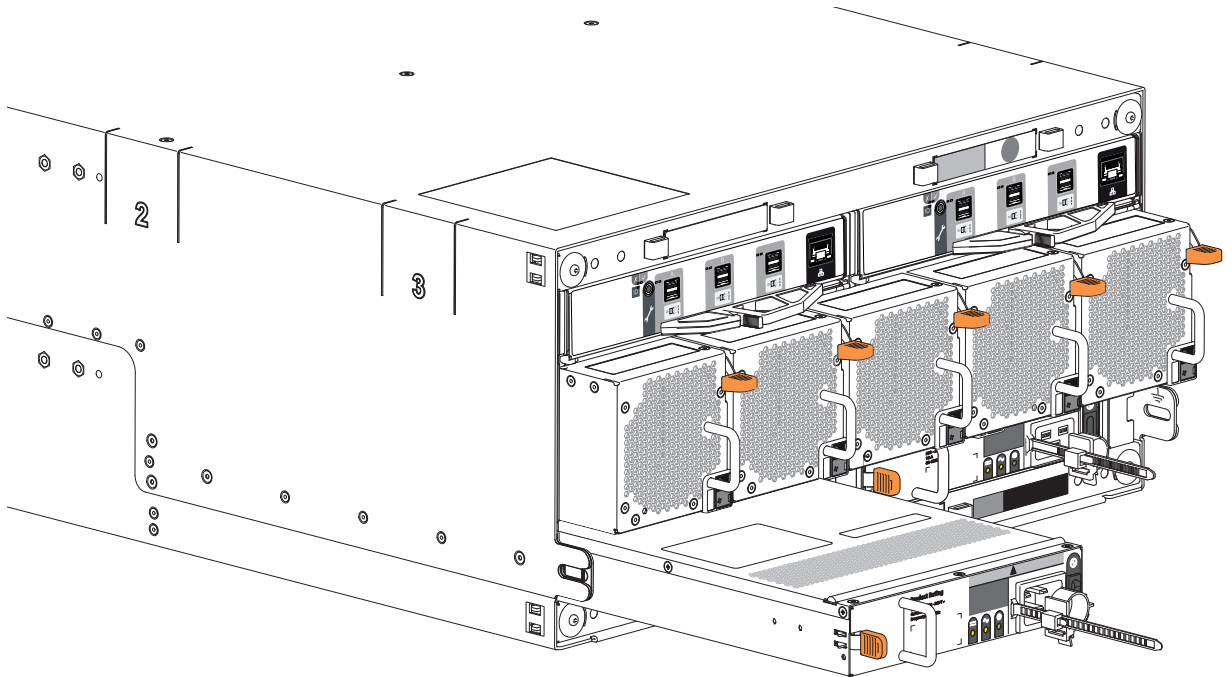

Figure 70 Power supply unit removal

- d. Place it in a static-protected location.
5. Complete the following actions to replace the faulty PSU with a tested good one:
 - a. Facing the rear of the 5U enclosure, orient the new PSU with the latch to the left.

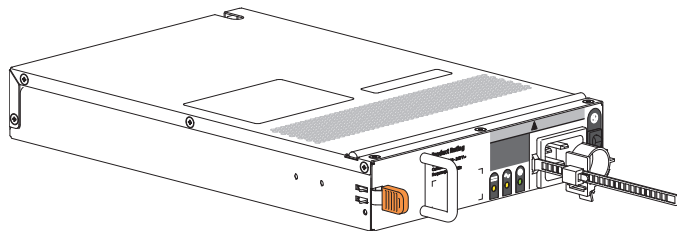

Figure 71 Replacement power supply unit

- b. Use one hand to support the weight of the PSU and the other to guide it into the empty PSU slot.
- c. Exerting even pressure to the center, gently press inward until it connects with the midplane and it locks in place.
- d. Connect the power cord, then move the PSU power switch to the ON position.
6. Verify that the *PSU OK* LED is lit green on the replaced PSU after properly inserting and seating it in the empty slot.

7. Facing the front of the 5U enclosure, verify that the *Power On* LED is green and there are no fault conditions.

A Technical specifications

Table 11 Expansion enclosure dimensions

Dimension type	2U12, 2U24		5U84	
	Metric units	Imperial units	Metric units	Imperial units
Height	87.90mm	3.46 in	220.00mm	8.65 in
Width, excluding rails	483.00mm	19.01 in	483.00mm	19.00 in
Depth, excluding cables	630.00mm	24.80 in	933.00mm	36.75 in

Table 12 Expansion enclosure FRU weights

FRU or component	Metric units	Imperial units
2U12 enclosure chassis plus midplane, no FRUs or rails	17.00Kg	38.00 lb
2U12 enclosure chassis, fully populated, no rails	up to 32.00Kg	up to 71.00 lb
2U24 enclosure chassis plus midplane, no FRUs or rails	17.00Kg	38.00 lb
2U24 enclosure chassis, fully populated	up to 30.00Kg	up to 66.00 lb
5U84 enclosure chassis plus midplane and drawers, no FRUs or rails	36.00Kg	79.40 lb
5U84 enclosure chassis, fully populated, no rails	up to 135.00Kg	up to 298.00 lb
Drive module, either 3.5-inch LFF in carrier or 2.5-inch SFF with adapter in carrier	up to 0.80Kg	up to 1.80 lb
Input/output module (IOM)	up to 0.70Kg	up to 1.50 lb
2U enclosure power cooling module (PCM)	1.45Kg	3.20 lb
5U enclosure fan cooling module (FCM)	0.80Kg	1.80 lb
5U enclosure power supply unit (PSU)	0.70Kg	1.50 lb
2U rack rails and hardware kit	2.75Kg	6.60 lb
5U rack rails and hardware kit	8.50Kg	18.74 lb

-All weights are nominal, can vary. Unit values for drives use the heaviest drive currently qualified.
 -Scale calibration impacts measured weights.

Table 13 Environmental specifications

Type	Operation	Storage, Non-operating	
		2U12, 2U24	5U84
Temperature, ASHRAE A2	5°C to 35°C (41°F to 95°F, derated by 1°C per 300m above 900m)	-40°C to +70°C (-40°F to +158°F) Maximum temperature change in an hour: 20°C	
Airflow	System must be operated with low pressure rear exhaust installation Back pressure created by rack doors and obstacles not to exceed 5 Pa (0.5mm H ₂ O)		
Altitude	-100 to 3000 meters (-330 to 10,000 feet) Maximum operating temperature is derated by 1°C for each 300m above 900m (2952.76 ft)	-100 to 12,192m (-328 to 40,000 ft)	
Relative humidity	-12°C dew point minimum 8% to 85% maximum, non-condensing	21°C dew point maximum 5% to 100% maximum, non-condensing	
Shock	5.0 Gs, 10ms (per axis)	15.0 Gs, 10ms, 10 shock pulses (X, Y, and Z axes)	20.0 Gs, 10ms (X and Y axes)
Vibration	0.21Grms 5Hz to 500Hz random, 30 min per axis	1.04Grms 2Hz to 200Hz random (ISTA 3E) Relocation: ISTA3H air ride for 60 min	
Acoustics	N/A		

Table 14 Power specifications

Type	Description	
	2U	5U
Input power requirements	100V to 240V AC, 50Hz to 60Hz	200V to 240V AC, 50Hz to 60Hz
Voltage	Max output: 580W	Max output: 2200W
	Range: 100V to 240V AC, rated	Range: 200V to 240V AC, rated
	Frequency: 50Hz to 60Hz	Frequency: 50Hz to 60Hz
Hot-swappable?	HDDs and SSDs (in chassis data slots), input/output modules (IOMs), and power cooling modules (PCMs)	HDDs and SSDs (in chassis data slots), input/output modules (IOMs), fan cooling modules (FCMs), and power supply units (PSUs)

B Standards and regulations

International standards

The expansion enclosure complies with the requirements of the following agencies and latest editions of these standards:

Table 15 Standard and approvals

Type	Specification	
Safety certifications	UL 60950-1; UL & cUL to UL 62368-1 2nd Ed	
	CAN/CSA-C22.2 No. 60950-1-07; No. 62368-1-14, 2nd Ed	
	CE to EN 60950-1; 62368-1	
	IEC 60950-1; 62368-1 2nd Ed (International)	
	CCC (China PRC - CCC PSUs)	
	BIS (India - BIS PSUs)	
Ecodesign	Commission Regulation (EU) 2019/424 (Directive 2009/125/EC)	
Emissions (EMC)	FCC CFR 47 Part 15 Subpart B Class A (United States)	
	ICES/NMB-003 Class A (Canada)	
	EN 55032 Class A, EN 55024, EN 61000-3-2, EN 61000-3-3 (Europe)	
	AS/NZS CISPR 32 Class A (Australia/New Zealand)	
	VCCI Class A (Japan)	
	KN 32 Class A/KN 35 (S. Korea)	
	CNS 13438 Class A (Taiwan)	
Harmonics	EN 61000-3-2 (EU)	
Flicker	EN 61000-3-3 (EU)	
Immunity	EN 55024 (EU)	
	KN 24/KN 35 (S. Korea)	
Environmental standards	The RoHS Directive (2011/65/EU)	
	The WEEE Directive (2012/19/EU)	
	The REACH Directive (EC/1907/2006)	
	The Batteries Directive (2006/66/EC)	
Standard marks, approvals	North America (FCC, UL, cUL, ICES/NMB-003 Class A)	China (CCC – PSU only)
	European Union (CE)	Japan (VCCI)
	Australia/New Zealand (RCM)	Korea (KC)
		Taiwan (BSMI)

WEEE recycling

ⓘ IMPORTANT Observe all applicable safety precautions detailed in the preceding chapters when dismantling and disposing of this equipment.

At the end of the product's life, all scrap or waste electrical and electronic equipment, recycle it in accordance with national regulations applicable to the handling of hazardous or toxic electrical and electronic waste materials.

Contact your supplier for a copy of the Recycling Procedures applicable to your country.

Index

2

2U12

large form factor (LFF) enclosure 10-11, 73, 82, 95

2U24

small form factor (SFF) enclosure 10-11, 73, 82, 95

A

assistance

minimum staff 20
no lift alone 22, 33

C

cabling

cable management system 16
power cords meeting product specifications 18, 20, 30-31, 44-45, 79, 92
route power cords 30, 44

chassis

access 21, 33
airflow 51
airflow paths 46
description 10-11, 95
positioning 26, 37
required equipment 21, 33
safe lifting technique 21, 33
securing 26, 38

components

enclosure front panel (84-drive) 13
enclosure front panel (LFF 12-drive) 11
enclosure front panel (SFF 24-drive) 11

corrective action 68-69

D

data path

components 66
fault tolerance 29, 43

disk groups 57, 67

drawer 40

access 14-15, 37
fault 61-62, 66, 71
fully latched 72, 74, 79, 83, 87, 90, 92
lock, unlock 40
population with drives 41

drive module

access 10-11, 13-14
carrier (DDIC) 27, 59, 62, 73-74, 82-83, 95
carrier latch 41
fault 49-50, 54-56, 59, 61-62, 68, 70, 74-75, 77, 83
fully latched, 2U 76
fully latched, 5U 86
large form factor (LFF) 10
mixed type, invalid, unknown 50, 54, 56
quarantine 83
small form factor (SFF) 10

E

electrical guidelines 19, 28, 31, 42, 46-47, 51-52

electrostatic discharge 73, 82

enclosure

cabling 28, 42
dimensions 95
installation checklist 18
site requirements 19
troubleshooting (basic steps) 66
weight 95

F

failure, hardware 66, 69

cable, connector, or switch 67, 70-71
drive module 70

fan module

cooling 10, 60, 64

fan modules 13, 78, 90

fault condition 65, 68-69

fault isolation 66

FRUs 83

replacement time limit, 2U 73
replacement time limit, 5U 74, 80, 82-83, 90, 92

H

host bus adapter (HBA) 57, 67

I

installation

minimum staff requirements 21, 33

L

LEDs

- controller module LEDs 65-66
- drawer panel LEDs 54, 66
- drive modules (SFF/LFF) 65-66
- expansion module LEDs 49-50, 55-56, 65-66, 77, 88
- front panel LEDs 65-66
- operators panel LEDs 48, 53, 58
- power cooling module LEDs 65

lift, mechanical

- adjust height 26, 37
- proper approach to rack cabinet 25-26, 37

N

notifications

- alerts 65-66
- events 65-66

P

power

- cords 30-31, 45, 57
- distribution unit (PDU) 46, 51
- prerequisites 28, 42, 96

power cycle 57

- power off, power down 47, 52
- power on, power up 46, 51

R

rack cabinet 25, 37

- leveling 20
- prerequisites 20

rackmount rail system 23, 34

- anatomy 23, 35
- installation 23, 34
- safety guidelines 22, 33

replacement, in-service FRU

- controller module 76, 87
- drive module or DDIC 74, 83
- fan cooling module (FCM) 90
- power cooling module (PCM) 78
- power supply unit (PSU) 91
- time limits 73, 82

return

- FRU for repair 74, 76, 83, 87
- packaging 21, 32
- storage enclosure 21, 32

S

safety precautions

- electrical 28, 42
- equipment disposal 97
- installation 25, 37
- rack cabinet 22, 33

sensors

- temperature 57

shipment

- original packaging damage 21, 32
- plastic bag 21, 32-33
- protective foam 21
- shock and vibration 95

storage enclosure

- lifting straps 33
- proper rack cabinet door clearance 20
- system airflow 10, 20, 46, 51, 90, 95
- temperature control 10, 46, 51, 90, 95
- total staff to install 20

T

temperature

- airflow, control 13, 15
- ambient 20, 46, 51, 69, 72
- issue 58, 60-61, 64, 69, 72
- sensors 57

time

- limit for FRU replacement 10, 16, 28, 42, 73-74, 76, 79, 82-83, 87, 90, 92

U

unit identification (UID)

- bit 50, 55-56, 59, 61-62, 65-66, 74, 83
- display 54